

Алматы (727)345-47-04
Ангарск (3955)60-70-56
Архангельск (8182)63-90-72
Астрахань (8512)99-46-04
Барнаул (3852)73-04-60
Белгород (4722)40-23-64
Благовещенск (4162)22-76-07
Брянск (4832)59-03-52
Владивосток (423)249-28-31
Владикавказ (8672)28-90-48
Владимир (4922)49-43-18
Волгоград (844)278-03-48
Вологда (8172)26-41-59
Воронеж (473)204-51-73
Екатеринбург (343)384-55-89

Иваново (4932)77-34-06
Ижевск (3412)26-03-58
Иркутск (395)279-98-46
Казань (843)206-01-48
Калининград (4012)72-03-81
Калуга (4842)92-23-67
Кемерово (3842)65-04-62
Киров (8332)68-02-04
Коломна (4966)23-41-49
Кострома (4942)77-07-48
Краснодар (861)203-40-90
Красноярск (391)204-63-61
Курск (4712)77-13-04
Курган (3522)50-90-47
Липецк (4742)52-20-81

Магнитогорск (3519)55-03-13
Москва (495)268-04-70
Мурманск (8152)59-64-93
Набережные Челны (8552)20-53-41
Нижний Новгород (831)429-08-12
Новокузнецк (3843)20-46-81
Ноябрьск (3496)41-32-12
Новосибирск (383)227-86-73
Омск (3812)21-46-40
Орел (4862)44-53-42
Оренбург (3532)37-68-04
Пенза (8412)22-31-16
Петрозаводск (8142)55-98-37
Пермь (8112)59-10-37
Пермь (342)205-81-47

Ростов-на-Дону (863)308-18-15
Рязань (4912)46-61-64
Самара (846)206-03-16
Санкт-Петербург (812)309-46-40
Саратов (845)249-38-78
Севастополь (8692)22-31-93
Саранск (8342)22-96-24
Симферополь (3652)67-13-56
Смоленск (4812)29-41-54
Сочи (862)225-72-31
Ставрополь (8652)20-65-13
Сургут (3462)77-98-35
Сыктывкар (8212)25-95-17
Тамбов (4752)50-40-97
Тверь (4822)63-31-35

Тольятти (8482)63-91-07
Томск (3822)98-41-53
Тула (4872)33-79-87
Тюмень (3452)66-21-18
Ульяновск (8422)24-23-59
Улан-Удэ (3012)59-97-51
Уфа (347)229-48-12
Хабаровск (4212)92-98-04
Чебоксары (8352)28-53-07
Челябинск (351)202-03-61
Череповец (8202)49-02-64
Чита (3022)38-34-83
Якутск (4112)23-90-97
Ярославль (4852)69-52-93

Россия +7(495)268-04-70

Казахстан +7(727)345-47-04

Беларусь +(375)257-127-884

Узбекистан +998(71)205-18-59

Киргизия +996(312)96-26-47

<https://magris.nt-rt.ru/> || mgq@nt-rt.ru



Sideflexing and straight guides

MakesMoving

sideflexing guides for TAB type chains

780 / 790 / 878 / 879 / 880 / 881 / 8811 SERIES

Sideflexing guides for chains - 82.5 K325 - 83.8 K330 P=85

TRACKS	A mm	R1= 500	R1= 610	R1= 650	R1= 800	R1=1000
1	100	CT182111	CT182121	CT182131	CT182141	CT182151
2	185	CT182211	CT182221	CT182231	CT182241	CT182251
3	270	CT182311	CT182321	CT182331	CT182341	CT182351
4	355	CT182411	CT182421	CT182431	CT182441	CT182451
5	440	CT182511	CT182521	CT182531	CT182541	CT182551
6	525	CT182611	CT182621	CT182631	CT182641	CT182651

Sideflexing guides for chains - 82.5 K325 - 83.8 K330 P=88

TRACKS	A mm	R1= 500	R1= 610	R1= 650	R1= 800	R1=1000
1	100	CT182111	CT182121	CT182131	CT182141	CT182151
2	188	CT182212	CT182222	CT182232	CT182242	CT182252
3	276	CT182312	CT182322	CT182332	CT182342	CT182352
4	364	CT182412	CT182422	CT182432	CT182442	CT182452
5	452	CT182512	CT182522	CT182532	CT182542	CT182552
6	540	CT182612	CT182622	CT182632	CT182642	CT182652

Sideflexing guides for chains - 82.5 K325 - 83.8 K330 P=90

TRACKS	A mm	R1= 500	R1= 610	R1= 650	R1= 800	R1=1000
1	100	CT182111	CT182121	CT182131	CT182141	CT182151
2	190	CT182213	CT182223	CT182233	CT182243	CT182253
3	280	CT182313	CT182323	CT182333	CT182343	CT182353
4	370	CT182413	CT182423	CT182433	CT182443	CT182453
5	460	CT182513	CT182523	CT182533	CT182543	CT182553
6	550	CT182613	CT182623	CT182633	CT182643	CT182653

Sideflexing guides for chain - 88.9 K350 P=90

TRACKS	A mm	R1= 500	R1= 610	R1= 650	R1= 800	R1=1000
1	100	CT188113	CT188123	CT188133	CT188143	CT188153
2	190	CT188213	CT188223	CT188233	CT188243	CT188253
3	280	CT188313	CT188323	CT188333	CT188343	CT188353
4	370	CT188413	CT188423	CT188433	CT188443	CT188453
5	460	CT188513	CT188523	CT188533	CT188543	CT188553
6	550	CT188613	CT188623	CT188633	CT188643	CT188653

Sideflexing guides for chain - 114.3 K450 P=120

TRACKS	A mm	R1= 610	R1= 650	R1= 800	R1= 1000
1	130	CT111124	CT111134	CT111144	CT111154
2	250	CT111224	CT111234	CT111244	CT111254
3	370	CT111324	CT111334	CT111344	CT111354
4	490	CT111424	CT111434	CT111444	CT111454
5	610	CT111524	CT111534	CT111544	CT111554
6	730	CT111624	CT111634	CT111644	CT111654

Sideflexing guides for chain - 190.5 K750 P=195

TRACKS	A mm	R1= 610	R1= 650	R1= 800	R1=1000
1	200	CT119126	CT119136	CT119146	CT119156
2	395	CT119226	CT119236	CT119246	CT119256
3	590	CT119326	CT119336	CT119346	CT119356
4	785	CT119426	CT119436	CT119446	CT119456

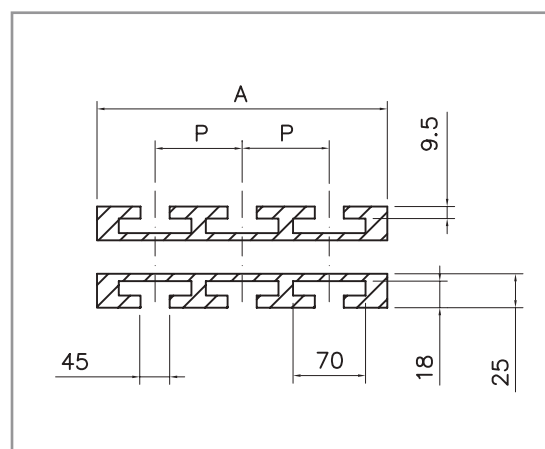
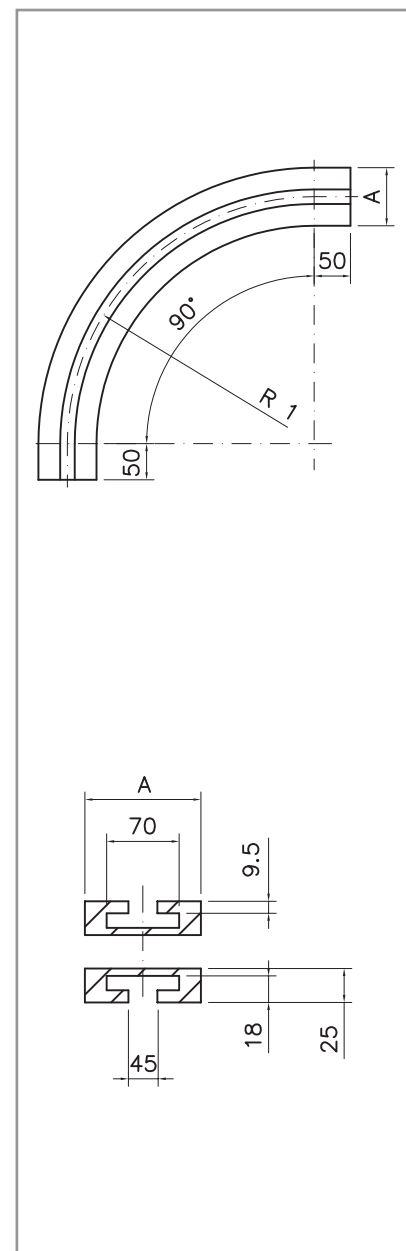

ALWAYS CHECK THE **A** DIMENSION

sideflexing guides for TAB type chains

780 / 790 / 878 / 879 / 880 / 881 / 8811 SERIES

Sideflexing guides for chains - 82.5 K325 - 83.8 K330 - Without the L section - P=90mm

TRACKS	A mm	B	h	L	R1= 500
1	100	70	9.5	-	DT182113
2	190	70	9.5	-	DT182213
3	280	70	9.5	-	DT182313
4	370	70	9.5	-	DT182413
5	460	70	9.5	-	DT182513
6	550	70	9.5	-	DT182613

Sideflexing guides for chains - 82.5 K325 - 83.8 K330 - With the L section - P on request

TRACKS	A mm	B	h	L	R1= 500
1	100	67	10.5	50	WT18211
2	A1	67	10.5	50	WT18221*
3	A1	67	10.5	50	WT18231*
4	A1	67	10.5	50	WT18241*
5	A1	67	10.5	50	WT18251*
6	A1	67	10.5	50	WT18261*

* specify pitch P

Sideflexing guides for chain - 114.3 K450 - Without the L section - P=120mm

TRACKS	A mm	B	h	L	R1= 610
1	125	70	9.5	-	DT111124
2	245	70	9.5	-	DT111224
3	365	70	9.5	-	DT111324
4	485	70	9.5	-	DT111424
5	605	70	9.5	-	DT111524
6	725	70	9.5	-	DT111624

Sideflexing guides for chain - 114.3 K450 - With the L section - pitch P on request

TRACKS	A mm	B	h	L	R1= 610
1	130	67	10.5	50	WT11112
2	A1	67	10.5	50	WT11122*
3	A1	67	10.5	50	WT11132*
4	A1	67	10.5	50	WT11142*
5	A1	67	10.5	50	WT11152*
6	A1	67	10.5	50	WT11162*

* specify pitch P

Sideflexing guides for chain - 190.5 K750 - Without the L section - P=195mm

TRACKS	A mm	B	h	L	R1= 610
1	200	70	9.5	-	DT119126
2	395	70	9.5	-	DT119226
3	590	70	9.5	-	DT119326
4	785	70	9.5	-	DT119426

Sideflexing guides for chain - 190.5 K750 - With the L section - pitch P on request

TRACKS	A mm	B	h	L	R1=610
1	210	67	10.5	50	WT11912
2	A1	67	10.5	50	WT11922*
3	A1	67	10.5	50	WT11932*
4	A1	67	10.5	50	WT11942*

* specify pitch P

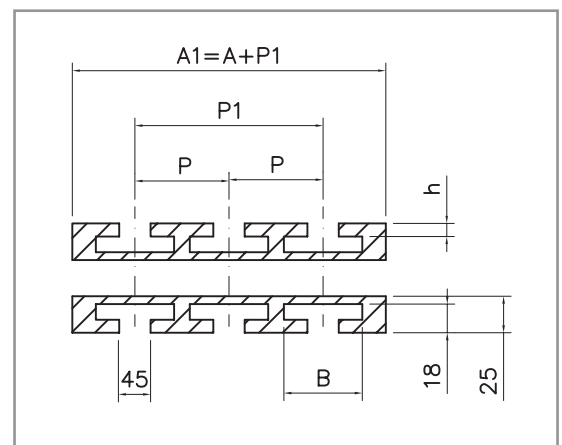
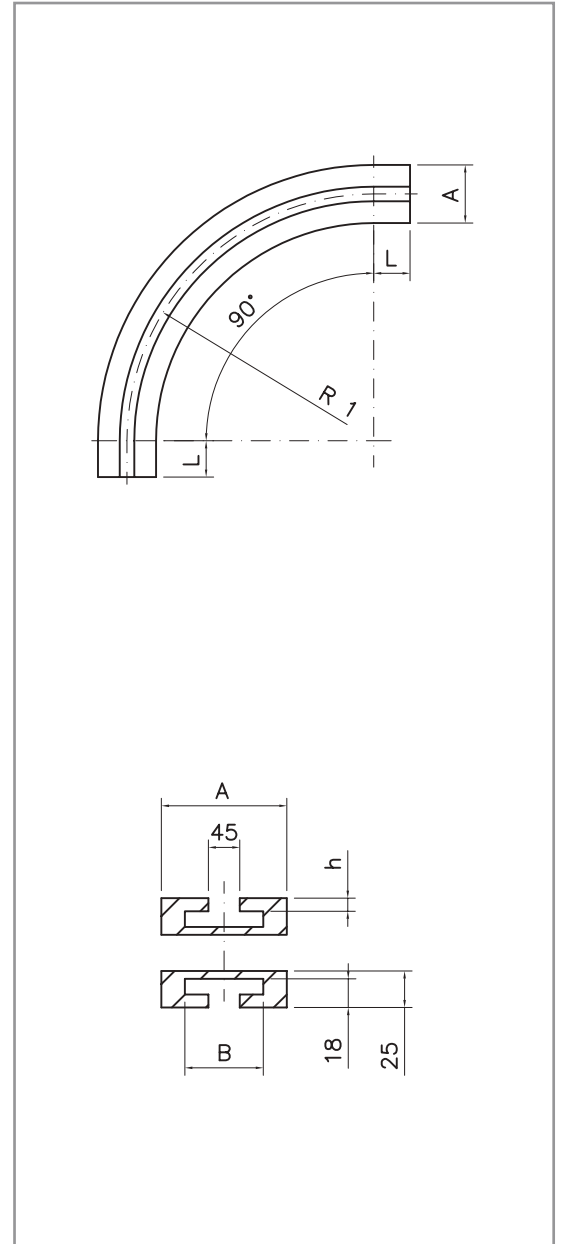

ALWAYS CHECK THE **A** DIMENSION

sideflexing guides for BEVEL 8° type chains

879 / 880 / 881 / 8811 SERIES

Sideflexing guides for chain - 82.5 K325 P=85

TRACKS	A mm	R1= 500	R1= 610	R1= 650	R1= 800	R1=1000
1	100	CB182111	CB182121	CB182131	CB182141	CB182151
2	185	CB182211	CB182221	CB182231	CB182241	CB182251
3	270	CB182311	CB182321	CB182331	CB182341	CB182351
4	355	CB182411	CB182421	CB182431	CB182441	CB182451
5	440	CB182511	CB182521	CB182531	CB182541	CB182551
6	525	CB182611	CB182621	CB182631	CB182641	CB182651

Sideflexing guides for chain - 82.5 K325 P=88

TRACKS	A mm	R1= 500	R1= 610	R1= 650	R1= 800	R1=1000
1	100	CB182111	CB182121	CB182131	CB182141	CB182151
2	188	CB182212	CB182222	CB182232	CB182242	CB182252
3	276	CB182312	CB182322	CB182332	CB182342	CB182352
4	364	CB182412	CB182422	CB182432	CB182442	CB182452
5	452	CB182512	CB182522	CB182532	CB182542	CB182552
6	540	CB182612	CB182622	CB182632	CB182642	CB182652

Sideflexing guides for chain - 82.5 K325 P=90

TRACKS	A mm	R1= 500	R1= 610	R1= 650	R1= 800	R1=1000
1	100	CB182111	CB182121	CB182131	CB182141	CB182151
2	190	CB182213	CB182223	CB182233	CB182243	CB182253
3	280	CB182313	CB182323	CB182333	CB182343	CB182353
4	370	CB182413	CB182423	CB182433	CB182443	CB182453
5	460	CB182513	CB182523	CB182533	CB182543	CB182553
6	550	CB182613	CB182623	CB182633	CB182643	CB182653

Sideflexing guides for chain - 88.9 K350 P=90

TRACKS	A mm	R1= 500	R1= 610	R1= 650	R1= 800	R1=1000
1	100	CB188113	CB188123	CB188133	CB188143	CB188153
2	190	CB188213	CB188223	CB188233	CB188243	CB188253
3	280	CB188313	CB188323	CB188333	CB188343	CB188353
4	370	CB188413	CB188423	CB188433	CB188443	CB188453
5	460	CB188513	CB188523	CB188533	CB188543	CB188553
6	550	CB188613	CB188623	CB188633	CB188643	CB188653

Sideflexing guides for chain - 114.3 K450 P=120

TRACKS	A mm	R1= 610	R1= 650	R1= 800	R1= 1000
1	130	CB111124	CB111134	CB111144	CB111154
2	250	CB111224	CB111234	CB111244	CB111254
3	370	CB111324	CB111334	CB111344	CB111354
4	490	CB111424	CB111434	CB111444	CB111454
5	610	CB111524	CB111534	CB111544	CB111554
6	730	CB111624	CB111634	CB111644	CB111654

Sideflexing guides for chain - 190.5 K750 P=195

TRACKS	A mm	R1= 610	R1= 650	R1= 800	R1=1000
1	200	CB119126	CB119136	CB119146	CB119156
2	395	CB119226	CB119236	CB119246	CB119256
3	590	CB119326	CB119336	CB119346	CB119356
4	785	CB119426	CB119436	CB119446	CB119456

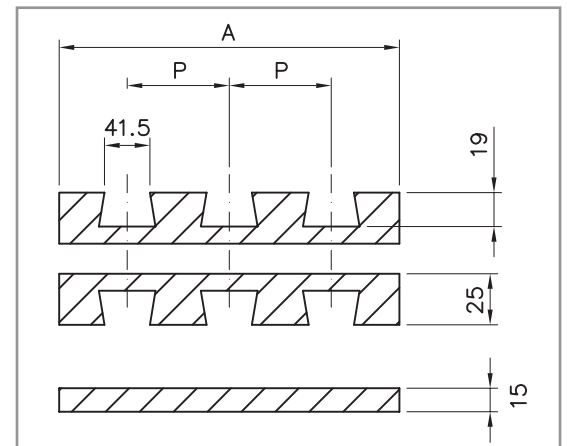
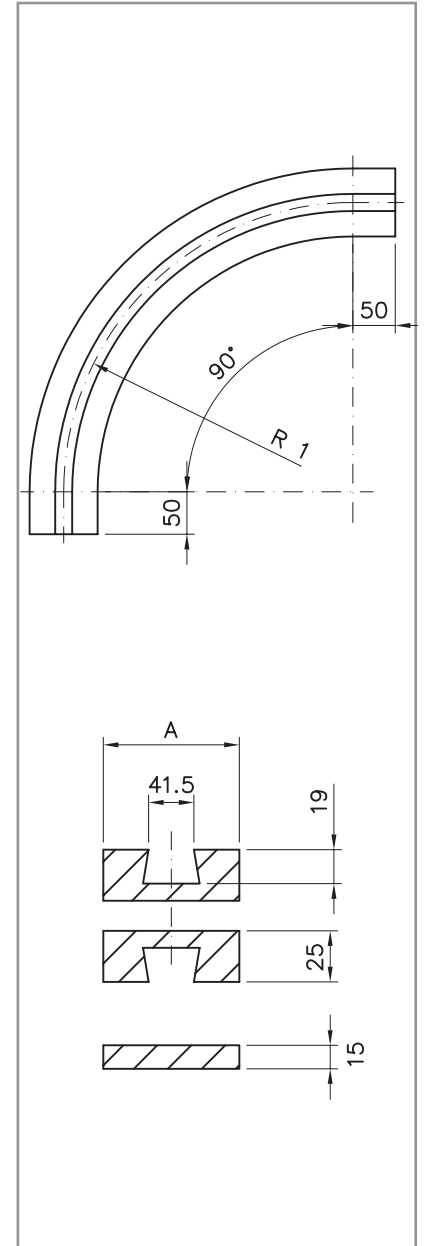

ALWAYS CHECK THE **A** DIMENSION

sideflexing guides for BEVEL 8° type chains

879 / 880 / 881 / 8811 SERIES

Sideflexing guides for chain - 82.5 K325 - Without the L section - P=90mm

TRACKS	A mm	h	h1	L	R1= 500
1	100	18	16	-	DB182113
2	190	18	16	-	DB182213
3	280	18	16	-	DB182313
4	370	18	16	-	DB182413
5	460	18	16	-	DB182513
6	550	18	16	-	DB182613

Sideflexing guides for chain - 82.5 K325 - With the L section - pitch P on request

TRACKS	A mm	h	h1	L	R1= 500
1	100	17	15	50	WB18211
2	A1	17	15	50	WB18221*
3	A1	17	15	50	WB18231*
4	A1	17	15	50	WB18241*
5	A1	17	15	50	WB18251*
6	A1	17	15	50	WB18261*

* specify pitch P

Sideflexing guides for chain - 114.3 K450 - Without the L section - P=120mm

TRACKS	A mm	h	h1	L	R1= 610
1	125	18	16	-	DB111124
2	245	18	16	-	DB111224
3	365	18	16	-	DB111324
4	485	18	16	-	DB111424
5	605	18	16	-	DB111524
6	725	18	16	-	DB111624

Sideflexing guides for chain - 114.3 K450 - With the L section - pitch P on request

TRACKS	A mm	h	h1	L	R1= 610
1	130	17	15	50	WB11112
2	A1	17	15	50	WB11122*
3	A1	17	15	50	WB11132*
4	A1	17	15	50	WB11142*
5	A1	17	15	50	WB11152*
6	A1	17	15	50	WB11162*

* specify pitch P

Sideflexing guides for chain - 190.5 K750 - Without the L section - P=195mm

TRACKS	A mm	h	h1	L	R1= 610
1	200	18	16	-	DB119126
2	395	18	16	-	DB119226
3	590	18	16	-	DB119326
4	785	18	16	-	DB119426

Sideflexing guides for chain - 190.5 K750 - With the L section - pitch P on request

TRACKS	A mm	h	h1	L	R1=610
1	210	17	15	50	WB11912
2	A1	17	15	50	WB11922*
3	A1	17	15	50	WB11932*
4	A1	17	15	50	WB11942*

* specify pitch P

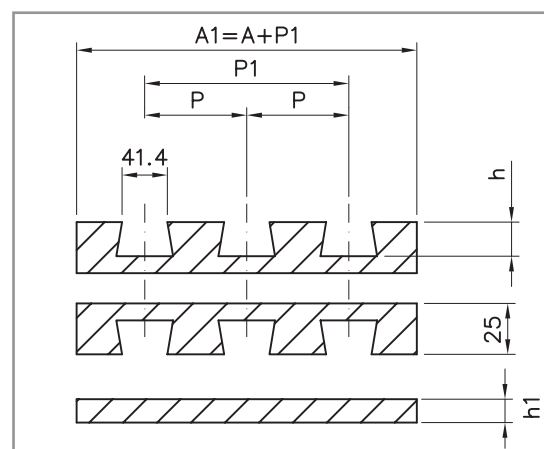
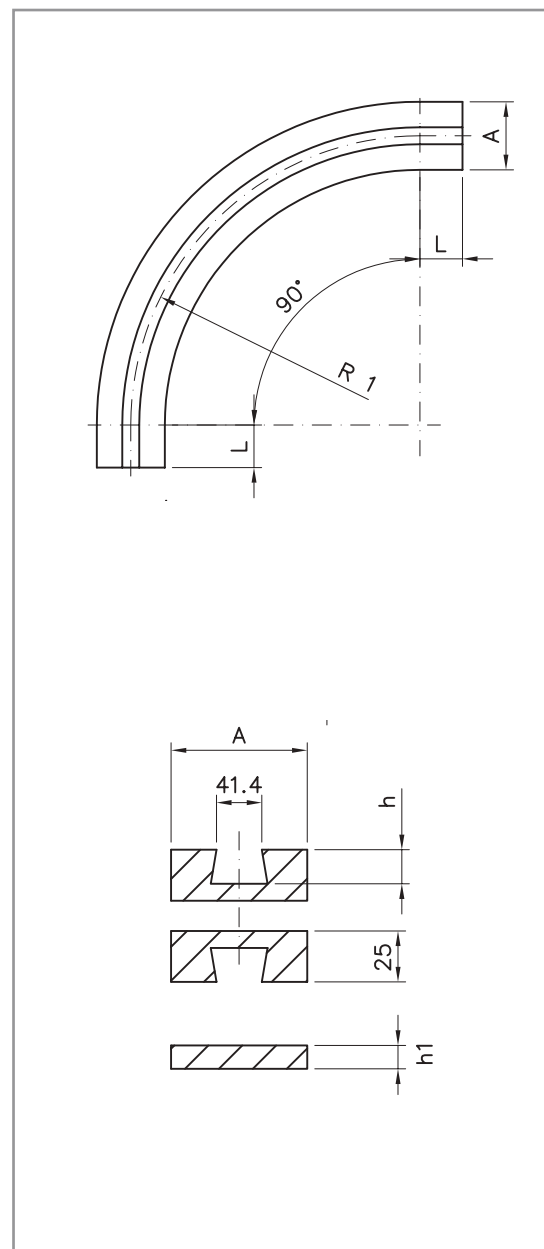

ALWAYS CHECK THE **A** DIMENSION

sideflexing guides for TAB type chains

882 TAB / LBP 882 TAB SERIES

Sideflexing guides for chain - 114.3 K450 P=120

TRACKS	A mm	R1= 610	R1= 650	R1=800	R1=1000
1	130	CT211124	CT211134	CT211144	CT211154
2	250	CT211224	CT211234	CT211244	CT211254
3	370	CT211324	CT211334	CT211344	CT211354
4	490	CT211424	CT211434	CT211444	CT211454
5	610	CT211524	CT211534	CT211544	CT211554
6	730	CT211624	CT211634	CT211644	CT211654

Sideflexing guides for chain - 190.5 K750 P=195

TRACKS	A mm	R1= 610	R1= 650	R1=800	R1=1000
1	200	CT219126	CT219136	CT219146	CT219156
2	395	CT219226	CT219236	CT219246	CT219256
3	590	CT219326	CT219336	CT219346	CT219356
4	785	CT219426	CT219436	CT219446	CT219456

Sideflexing guides for chain - 254.0 K1000 P=260

TRACKS	A mm	R1= 610	R1= 650	R1=800	R1=1000
1	270	CT225127	CT225137	CT225147	CT225157
2	530	CT225227	CT225237	CT225247	CT225257
3	790	CT225327	CT225337	CT225347	CT225357
4	1050	CT225427	CT225437	CT225447	CT225457

Sideflexing guides for chain - 304.8 K1200 P=310

TRACKS	A mm	R1= 610	R1= 650	R1=800	R1=1000
1	320	CT230128	CT230138	CT230148	CT230158
2	630	CT230228	CT230238	CT230248	CT230258
3	940	CT230328	CT230338	CT230348	CT230358
4	1250	CT230428	CT230438	CT230448	CT230458

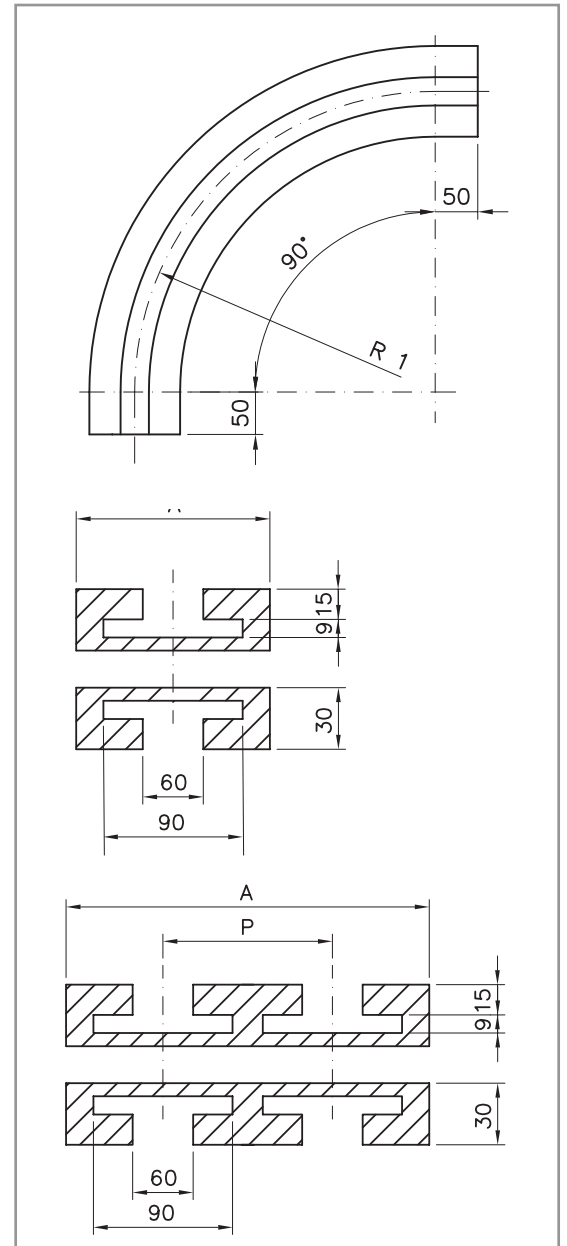

ALWAYS CHECK THE **A** DIMENSION

sideflexing guides for chains

882 TAB / 882 BEVEL SERIES

Sideflexing guides for chain
BEVEL 8° 114.3 K450 P=120

TRACKS	A mm	R1= 610
1	125	DB211124
2	245	DB211224
3	365	DB211324
4	485	DB211424

Sideflexing guides for chain
TAB 114.3 K450

TRACKS	A mm	R1= 610
1	130	DT21112
2	A1	DT21122*
3	A1	DT21132*
4	A1	DT21142*

* specify pitch P

Sideflexing guides for chain
BEVEL 8° 190.5 K750 P=195

TRACKS	A mm	R1= 610
1	200	DB219126
2	395	DB219226
3	590	DB219326
4	785	DB219426

Sideflexing guides for chain
TAB 190.5 K750

TRACKS	A mm	R1= 610
1	130	DT21912
2	A1	DT21922*
3	A1	DT21932*
4	A1	DT21942*

* specify pitch P

Sideflexing guides for chain
BEVEL 8° 254.0 K1000 P=260

TRACKS	A mm	R1= 610
1	265	DB225127
2	525	DB225227
3	785	DB225327

Sideflexing guides for chain
TAB 254.0 K1000

TRACKS	A mm	R1= 610
1	270	DT22512
2	A1	DT22522*
3	A1	DT22532*
4	A1	DT22542*

* specify pitch P

Sideflexing guides for chain
TAB 304.8 K1200

TRACKS	A mm	R1= 610
1	320	DT23012
2	A1	DT23022*
3	A1	DT23032*
4	A1	DT23042*

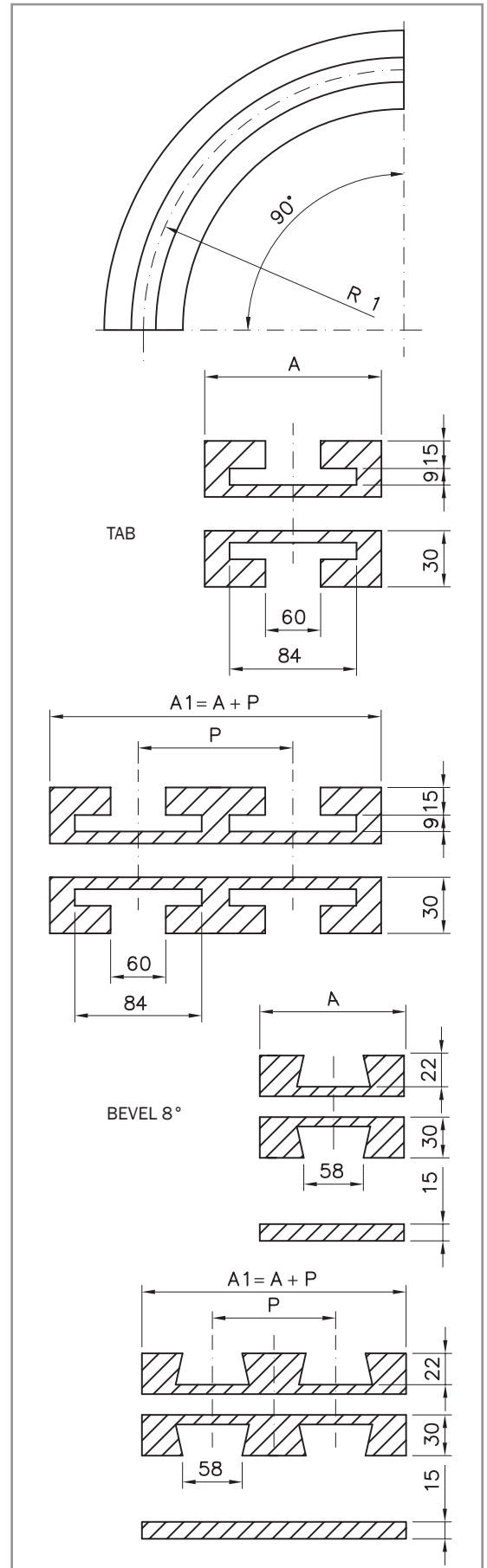

ALWAYS CHECK THE **A** DIMENSION

sideflexing guides for BEVEL 8° type chains

882 SERIES

Sideflexing guides for chain - 114.3 K450 P=120

TRACKS	A mm	R1= 610	R1= 650	R1=800	R1=1000
1	125	CB211124	CB211134	CB211144	CB211154
2	245	CB211224	CB211234	CB211244	CB211254
3	365	CB211324	CB211334	CB211344	CB211354
4	485	CB211424	CB211434	CB211444	CB211454

Sideflexing guides for chain - 190.5 K750 P=195

TRACKS	A mm	R1= 610	R1= 650	R1=800	R1=1000
1	200	CB219126	CB219136	CB219146	CB219156
2	395	CB219226	CB219236	CB219246	CB219256
3	590	CB219326	CB219336	CB219346	CB219356
4	785	CB219426	CB219436	CB219446	CB219456

Sideflexing guides for chain - 254.0 K1000 P=260

TRACKS	A mm	R1= 610	R1= 650	R1=800	R1=1000
1	265	CB225127	CB225137	CB225147	CB225157
2	525	CB225227	CB225237	CB225247	CB225257
3	785	CB225327	CB225337	CB225347	CB225357

Sideflexing guides for chain - 304.8 K1200 P=310

TRACKS	A mm	R1= 610	R1= 650	R1=800	R1=1000
1	320	CT230128	CT230138	CT230148	CT230158
2	630	CT230228	CT230238	CT230248	CT230258
3	940	CT230328	CT230338	CT230348	CT230358

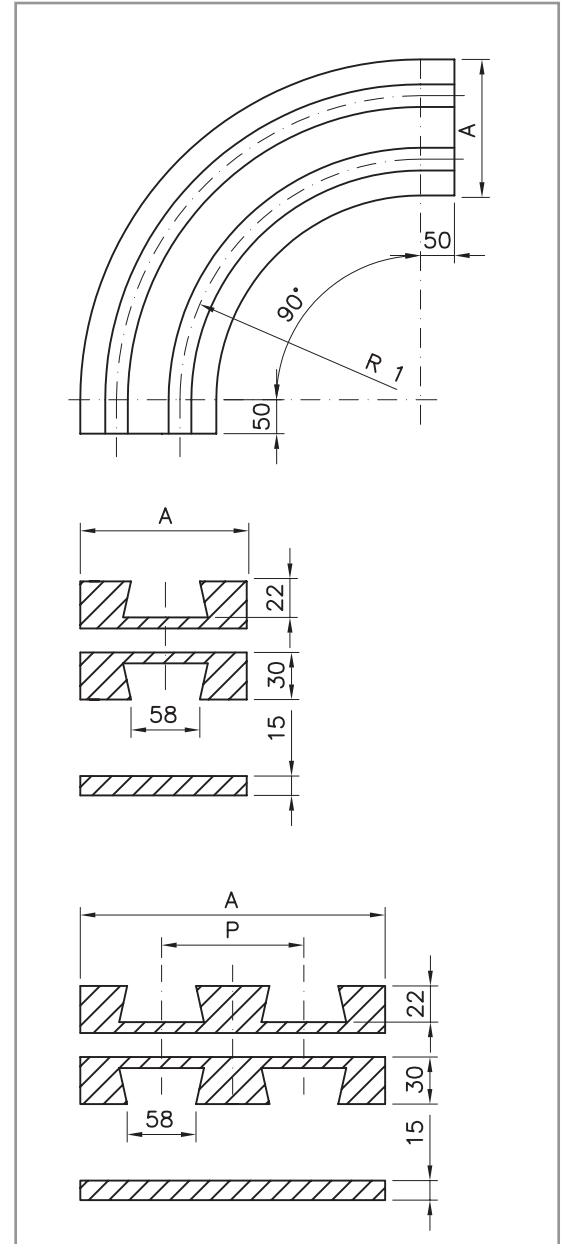

ALWAYS CHECK THE **A** DIMENSION

sideflexing guides for TAB type chains

1863 / 1873 / 1874 SERIES

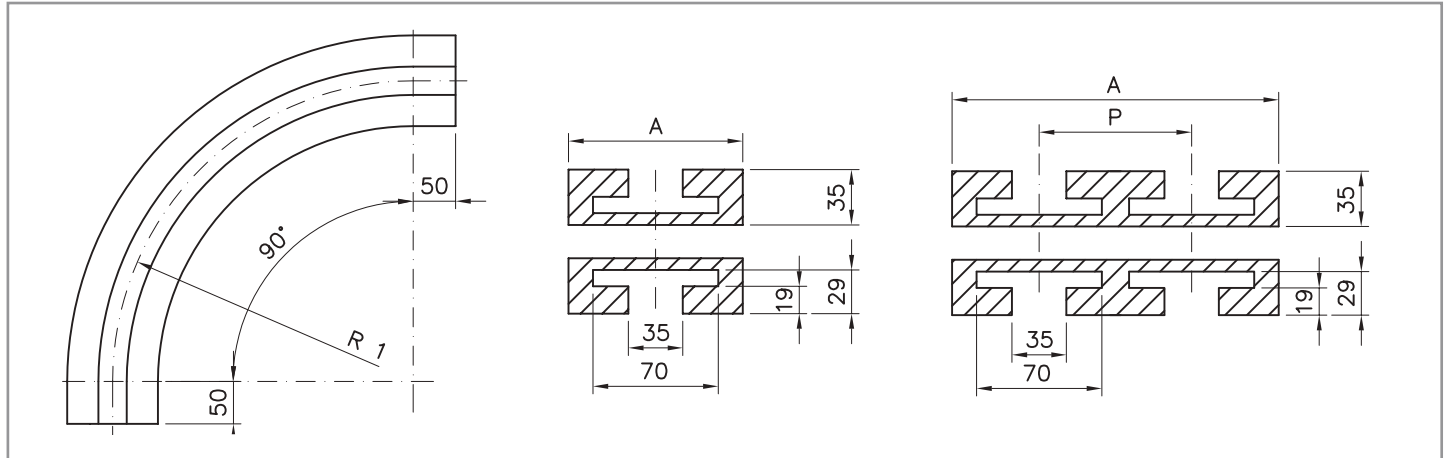

Sideflexing guides for chain - 57.1 K225 P=70

TRACKS	A mm	R1= 380	R1= 500	R1= 610	R1= 800	R1= 1000
1	75	CT45710	CT45711	CT45712	CT45714	CT45715
2	145	CT457209	CT457219	CT457229	CT457249	CT457259
3	215	CT457309	CT457319	CT457329	CT457349	CT457359
4	285	CT457409	CT457419	CT457429	CT457449	CT457459

Sideflexing guides for chain - 82.5 K325 P=85

TRACKS	A mm	R1= 380	R1= 500	R1= 610	R1= 650	R1= 800	R1= 1000
1	100	CT48210	CT48211	CT48212	CT48213	CT48214	CT48215
2	185	CT482201	CT482211	CT482221	CT482231	CT482241	CT482251
3	270	CT482301	CT482311	CT482321	CT482331	CT482341	CT482351
4	355	CT482401	CT482411	CT482421	CT482431	CT482441	CT482451

Sideflexing guides for chain - 82.5 K325 P=88

TRACKS	A mm	R1= 500	R1= 610	R1= 650	R1= 800	R1= 1000
1	100	CT48211	CT48212	CT48213	CT48214	CT48215
2	190	CT482212	CT482222	CT482232	CT482242	CT482252
3	280	CT482312	CT482322	CT482332	CT482342	CT482352
4	370	CT482412	CT482422	CT482432	CT482442	CT482452

Sideflexing guides for chain - 82.5 K325 P=90

TRACKS	A mm	R1= 500	R1= 610	R1= 650	R1= 800	R1= 1000
1	100	CT48211	CT48212	CT48213	CT48214	CT48215
2	190	CT482213	CT482223	CT482233	CT482243	CT482253
3	280	CT482313	CT482323	CT482333	CT482343	CT482353
4	370	CT482413	CT482423	CT482433	CT482443	CT482453

Sideflexing guides for chain - 114.3 K450 P=120

TRACKS	A mm	R1= 380	R1= 500	R1= 610	R1= 650	R1= 800	R1= 1000
1	130	CT411104	CT411114	CT411124	CT411134	CT411144	CT411154
2	250	CT411204	CT411214	CT411224	CT411234	CT411244	CT411254
3	370	CT411304	CT411314	CT411324	CT411334	CT411344	CT411354
4	490	CT411404	CT411414	CT411424	CT411434	CT411444	CT411454

ALWAYS CHECK THE **A** DIMENSION

sideflexing guides for TAB type chains

1863 / 1873 / 1874 SERIES

Sideflexing guides for chain
152.4 K600 P=160

TRACKS	A mm	R1= 500	R1= 610	R1= 650	R1= 800	R1= 1000
1	170	CT415115	CT415125	CT415135	CT415145	CT415155
2	330	CT415215	CT415225	CT415235	CT415245	CT415255
3	490	CT415315	CT415325	CT415335	CT415345	CT415355
4	650	CT415415	CT415425	CT415435	CT415445	CT415455

Sideflexing guides for chain
190.5 K750 P=195

TRACKS	A mm	R1= 500	R1= 610	R1= 650	R1= 800	R1= 1000
1	200	CT419116	CT419126	CT419136	CT419146	CT419156
2	395	CT419216	CT419226	CT419236	CT419246	CT419256
3	590	CT419316	CT419326	CT419336	CT419346	CT419356
4	785	CT419416	CT419426	CT419436	CT419446	CT419456

Sideflexing guides for chain
254.0 K1000 P=260

TRACKS	A mm	R1= 500	R1= 610	R1= 650	R1= 800	R1= 1000
1	270	CT425117	CT425127	CT425137	CT425147	CT425157
2	530	CT425217	CT425227	CT425237	CT425247	CT425257

Sideflexing guides for chain
304.8 K1200 P=310

TRACKS	A mm	R1= 500	R1= 610	R1= 650	R1= 800	R1= 1000
1	320	CT430118	CT430128	CT430138	CT430148	CT430158
2	630	CT430218	CT430228	CT430238	CT430248	CT430258

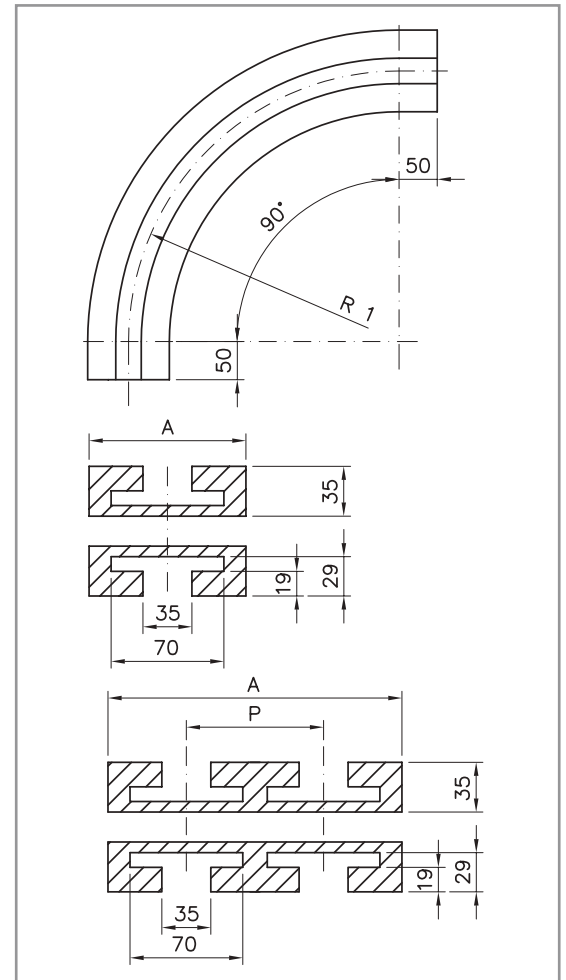

sideflexing guides for TAB type chains

1843 SERIES

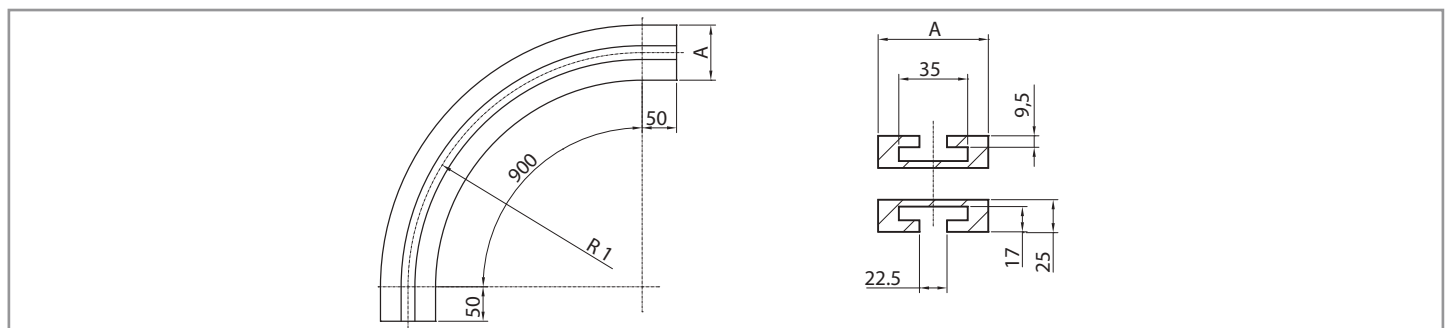

Sideflexing guides for chain
31.8 K125 50.8 K200 82.5 K325

CHAINS WIDTH	A mm	R1= 300	R1= 500
1	50	CT415115	CT415125
2	70	CT415215	CT415225
3	100	CT415315	CT415325

ALWAYS CHECK
THE **A** DIMENSION

sideflexing guides for TAB type chains

1863 / 1873 / 1874 SERIES

Sideflexing guides for chain
TAB 82.5 K325 P=90

TRACKS	A mm	R1= 500
1	100	DT482113
2	190	DT482213
3	280	DT482313
4	370	DT482413

Sideflexing guides for chain
TAB 114.3 K450 P=120

TRACKS	A mm	R1= 500
1	125	DT411114
2	245	DT411214
3	365	DT411314
4	485	DT411414

Sideflexing guides for chain
TAB 152.4 K600 P=160

TRACKS	A mm	R1= 610
1	160	DT415125
2	320	DT415225
3	480	DT415325
4	640	DT415425

Sideflexing guides for chain
TAB 190.5 K750 P=195

TRACKS	A mm	R1= 610
1	200	DT419126
2	395	DT419226
3	590	DT419326
4	785	DT419426

Sideflexing guides for chain
TAB 254.0 K1000 P=260

TRACKS	A mm	R1= 610
1	260	DT425127
2	520	DT425227

Sideflexing guides for chain
TAB 304.8 K1200 P=310

TRACKS	A mm	R1= 610
1	310	DT430128
2	620	DT430228

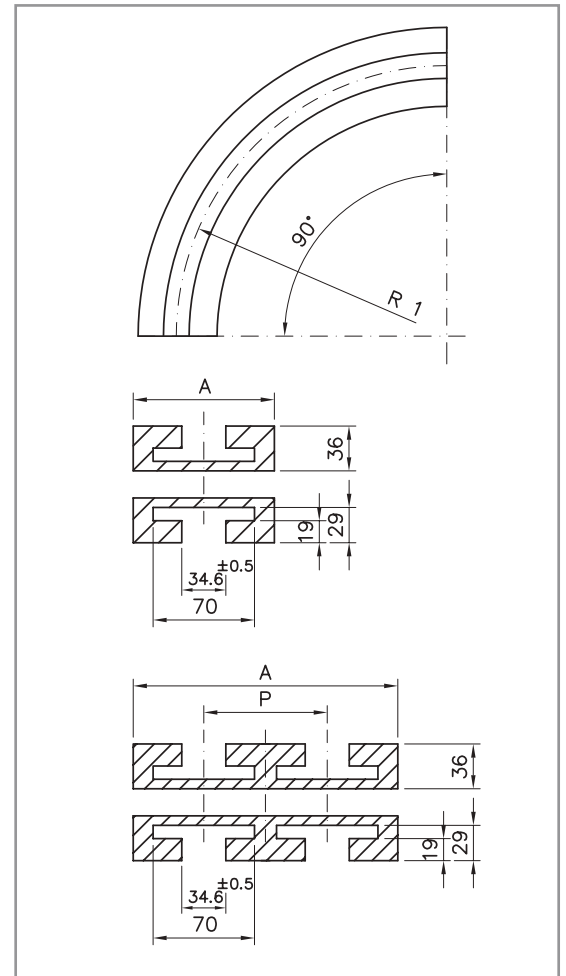

sideflexing guides for chains

1500 / 1700 / 1701 / 1702 SERIES

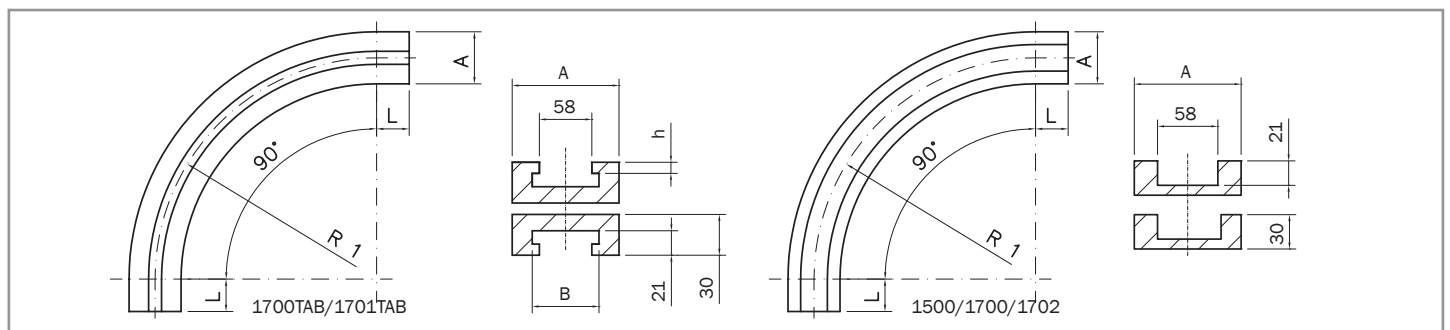

Sideflexing guides for chain
TAB 1700 / 1701 Series

A	B	h	R1	L	CODE
100	75	12	250	50	WT170000
100	75	12	500	50	WT170010
100	75	12	610	50	WT170020

Sideflexing guides for chain
1500 / 1700 / 1702 Series

A	R1	L	CODE
100	250	50	WX170000
100	500	50	WX170010
100	610	50	WX170020

ALWAYS CHECK
THE **A** DIMENSION

straight guides for TAB type chains

780 TAB / 790 TAB / 880 TAB / 881 TAB / 8811 TAB / 882 TAB /
1843 TAB / 1863 TAB / 1873 TAB / 1874 TAB SERIES

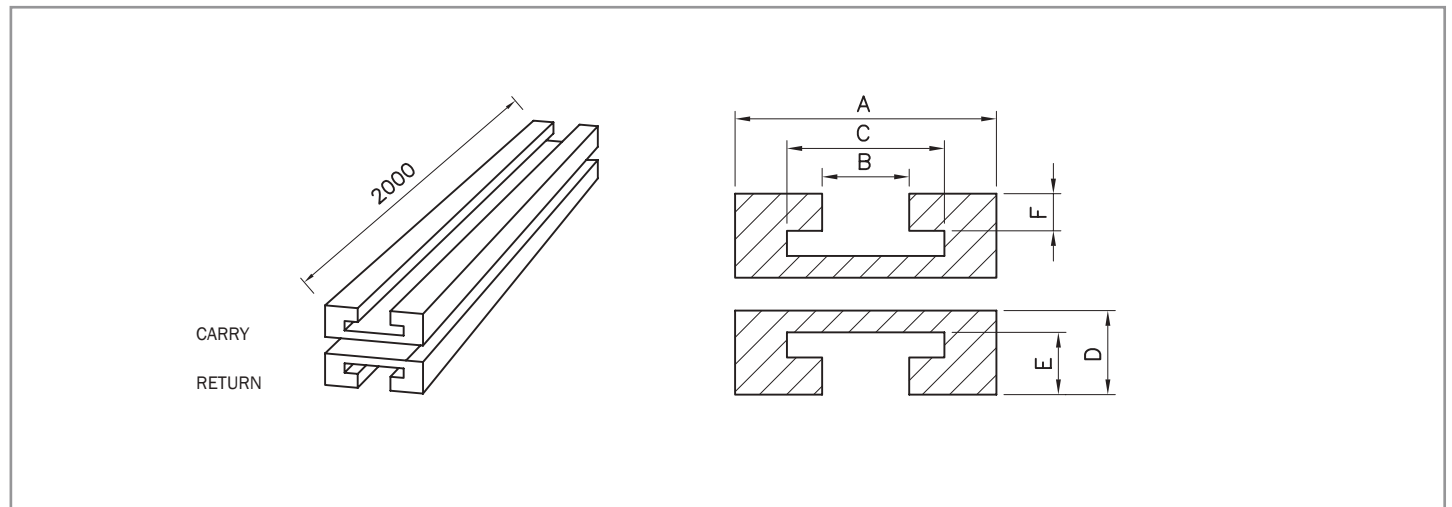

SELECTION TABLES

CHAINS TYPE	WIDTH	GUIDE CODE	A	B	C	D	E	F
880TAB K325	82,5	ST182100	100	45	67	25	18	9,5
881TAB K325								
8811TAB K325								
780TAB K330	83,8	ST182100	100					
790TAB K330								
880TAB K330								
880TAB K450	114,3	ST111100	130					
881TAB K450								
8811TAB K450								
880TAB K750	190,5	ST119100	200					
881TAB K750								
8811TAB K750								

882TAB K450	114.3	ST211100	130	60	84	30	24	15
882TAB K750	190.5	ST219100	200					
882TAB K1000	254	ST225100	270					
882TAB K1200	304.8	ST230100	320					

1843 T K125	31.8	ST532100	50	22.5	35	25	17	9.5
1843 T K200	50.8	ST551100	70	22.3				
1843 T K325	82.5	ST582100	100	22.3				

1863 T K225	57.1	ST657100	75	35	67	35	29	19
1873/1874 T K325	82.5	ST482100	100		70			
1873/1874 T K450	114.3	ST411100	130					
1873/1874 T K600	152	ST415100	170					
1873/1874 T K750	190.5	ST419100	200					
1873/1874 T K1000	254	ST425100	270					
1873/1874 T K1200	304.8	ST430100	320					

Supply: 1 piece; carry return sections are supplied separately.

ALWAYS CHECK THE **A** DIMENSION

straight guides for BEVEL 8° type chains

879 / 880 / 881 / 8811 / 882 SERIES

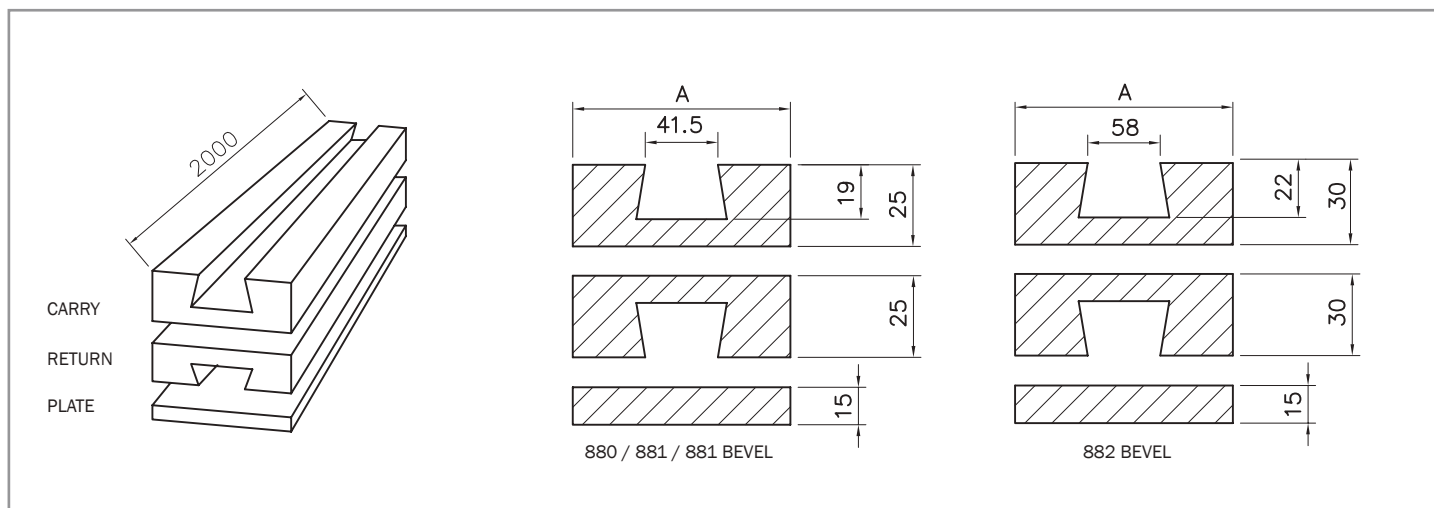

SELECTION TABLES

CHAINS TYPE	WIDTH	GUIDE CODE	RET. PLATE CODE	A
880 - K325	82,5	SB182100	RB182100	100
881 - K325				
8811 - K325				
880 - K450	114,3	SB188100	RB188100	130
881 - K450				
8811 - K450				
880 - K750	190,5	SB119100	RB119100	200
881 - K750				
8811 - K750				

882 - K450	114.3	SB211100	RB188100	130
882 - K750	190.5	SB219100	RB119100	200
882 - K1000	254.0	SB225100	RB225100	270

Supply: 1 piece; carry return sections and return plates are supplied separately.

ALWAYS CHECK THE **A** DIMENSION

guides for straight running type chains

812 / 815 / 8127 / 802 / 8811M / 8817M / 820

828 / 8257 / 821 / 879M / 880M / 882M / 720 / 730 / 780M / 790M SERIES

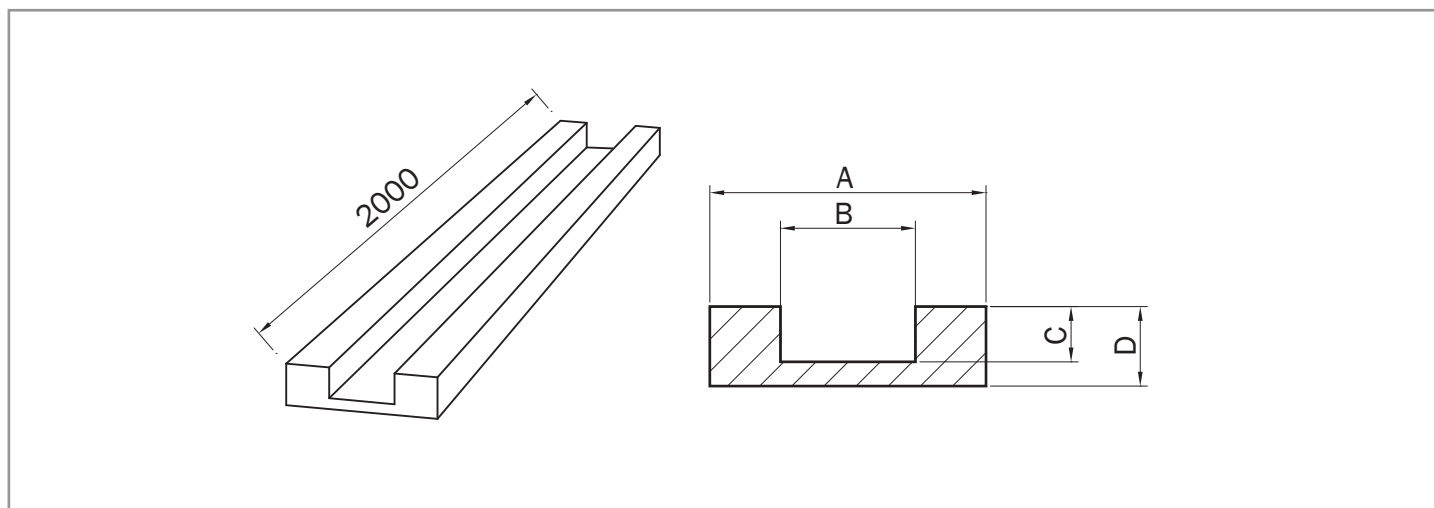

ALWAYS CHECK THE **A** DIMENSION

Guides for straight running type chains

812 / 815 / 8811M / 820 / 828 / 879M / 880M / 720 / 730 / 780M / 790M SERIES

SELECTION TABLES

CHAINS TYPE	WIDTH	GUIDE CODE	A	B	C	D
M K325	82.5	SM182100	100	44.5	13.5	27
M K330	83.8					
M K450	114.3	SM111100	130			
M K750	190.5	SM119100	200			

K325	82.5	SD182100	100	44.5	13.5	25
K330	83.8					
K450	114.3	SD111100	130			
K750	190.5	SD119100	200			

Guides for straight running type chains

8127 / 8817 / 8257 / 882M / 802 / 821 SERIES

SELECTION TABLES

CHAINS TYPE	WIDTH	GUIDE CODE	A	B	C	D
8127 K750	190.5	SM219100	200	60	17	32
8817M K750						
8257 K750						
882M K750						
8257 K1000	254	SM225100	270	60	17	32
882M K1000						
8257 K1200	304.8	SM230100	320	60	17	32
882M K1200						
802 K750	190.5	SM819100	200	82.5	13.5	27
821 K750	190.5	SM919100	200	140	17	32
821 K1000	254	SM925100	260			
821 K1200	304.8	SM930100	320			

straight guides for biplanar type chains

1500 / 1700 / 1700TAB / 1701TAB SERIES

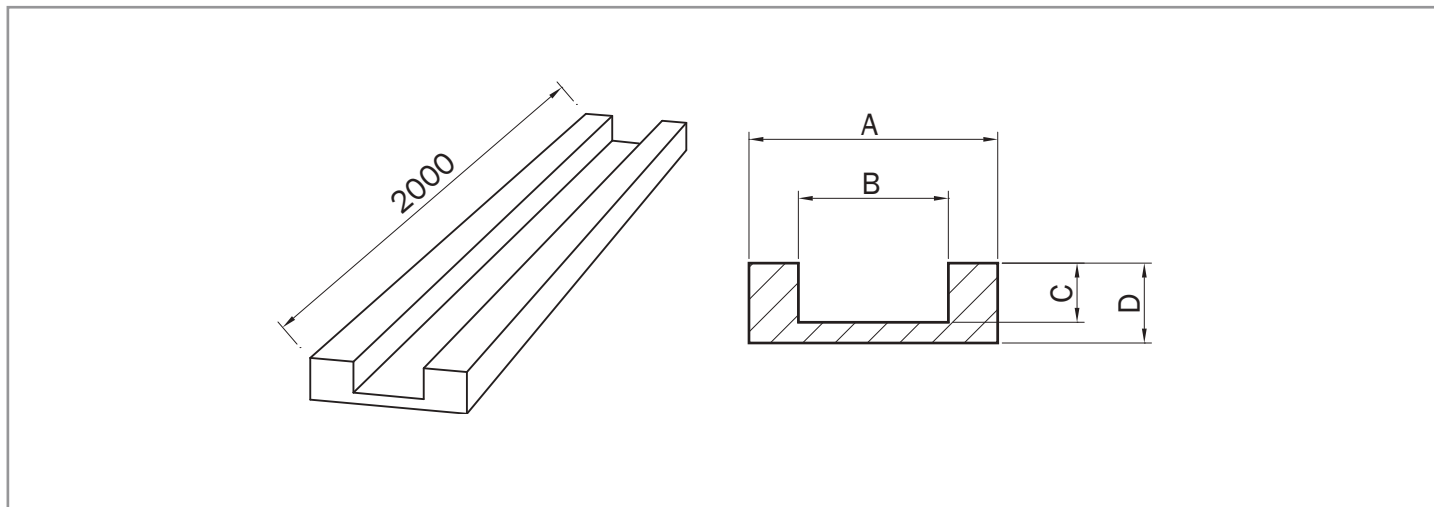

ALWAYS CHECK THE **A** DIMENSION

Straight guides for biplanar type chains
1500 / 1700 Series

SELECTION TABLES

CHAINS TYPE	WIDTH	GUIDE CODE	A	B	C	D
1500	55	SX170000	100	58	21	30
1700						

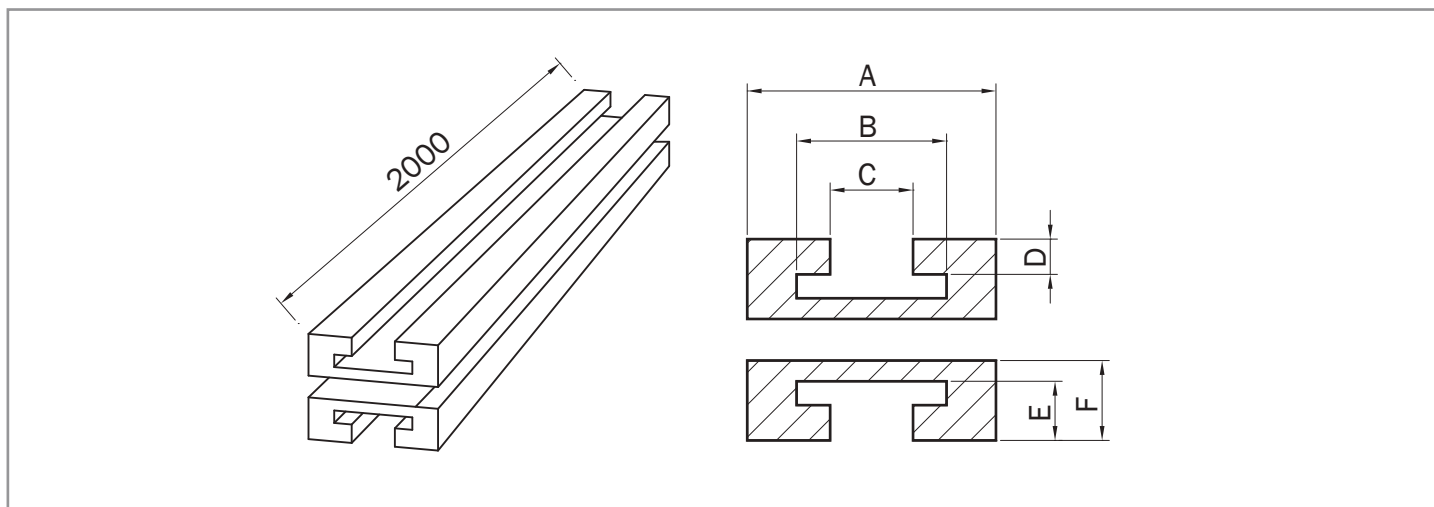

Straight guides for biplanar type chains
1700TAB / 1701TAB Series

SELECTION TABLES

CHAINS TYPE	WIDTH	GUIDE CODE	A	B	C	D	E	F
1700 TAB	55	ST170000	100	75	58	12	21	30
1701 TAB	53.3							

Supply: 1 piece; carry return sections are supplied separately.

guide rail profiles for conveyor chains

L standard

CODE	COLOUR	BARS	COILS	MATERIAL
PL000V	green	NO	40 / 60 mt	PEUHMW
PL000N	black	NO	40 / 60 mt	PEUHMW

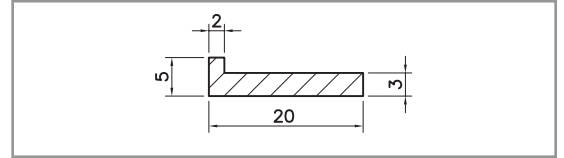

LK

CODE	COLOUR	BARS	COILS	MATERIAL
PLK00V	green	NO	40 / 60 mt	PEUHMW
PLK00N	black	NO	40 / 60 mt	PEUHMW

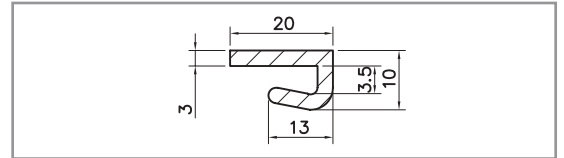

LK40

CODE	COLOUR	BARS	COILS	MATERIAL
PLK40V	green	NO	50 / 60 mt	PEUHMW
PLK40N	black	NO	50 / 60 mt	PEUHMW

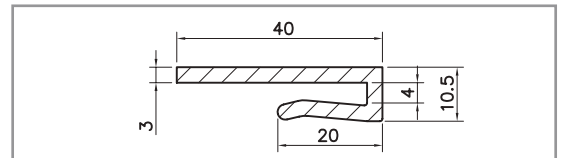

Z standard

CODE	COLOUR	BARS	COILS	MATERIAL
PZ000V	green	NO	50 / 60 mt	PEUHMW
PZ000N	black	NO	50 / 60 mt	PEUHMW

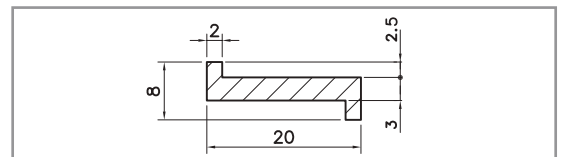

ZR

CODE	COLOUR	BARS	COILS	MATERIAL
PZR00V	green	NO	50 / 60 mt	PEUHMW
PZR00N	black	NO	50 / 60 mt	PEUHMW

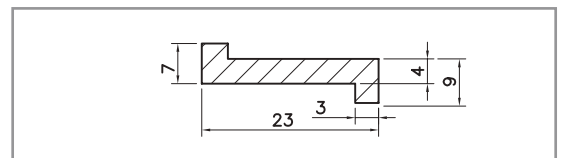

ZK

CODE	COLOUR	BARS	COILS	MATERIAL
PZK00V	green	NO	40 / 60 mt	PEUHMW
PZK00N	black	NO	40 / 60 mt	PEUHMW

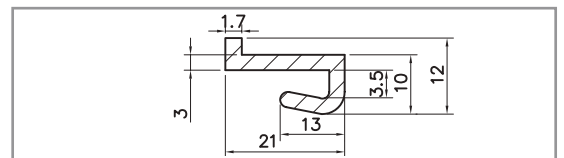

T standard

CODE	COLOUR	BARS	COILS	MATERIAL
PT000V	green	NO	50 / 60 mt	PEUHMW
PT000N	black	NO	50 / 60 mt	PEUHMW

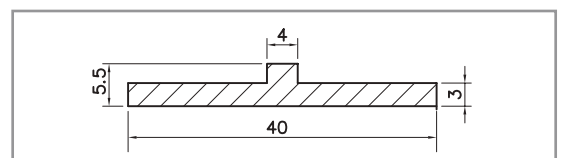

TR

CODE	COLOUR	BARS	COILS	MATERIAL
PTR00V	green	6 mt	50 / 60 mt	PEUHMW
PTR00N	black	6 mt	50 / 60 mt	PEUHMW

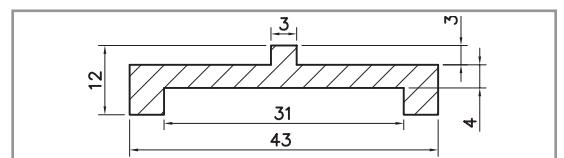

U

CODE	COLOUR	BARS	COILS	MATERIAL
PU000V	green	6 mt	50 / 60 mt	PEUHMW
PU000N	black	6 mt	50 / 60 mt	PEUHMW

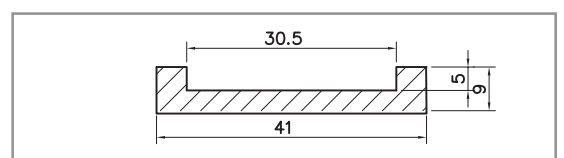

guide rail profiles for conveyor chains

U - 1

CODE	COLOUR	BARS	COILS	MATERIAL
PU100N	black	6 mt	50 / 60 mt	PEUHMW

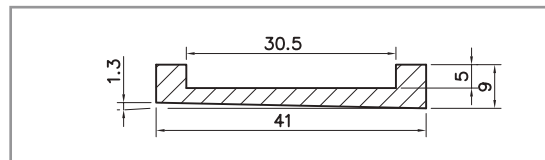

GL

CODE	COLOUR	BARS	COILS	MATERIAL
PGL00N	black	2 / 3 / 6 mt	50 mt	PEUHMW

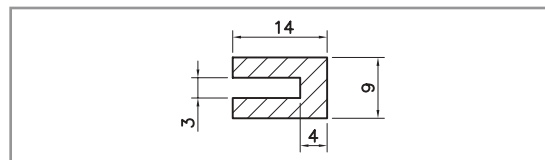

RP

CODE	COLOUR	BARS	COILS	MATERIAL
PRP00V	green	2 / 3 / 6 mt	NO	PEUHMW
PRP00N	black	2 / 3 / 6 mt	NO	PEUHMW
PRP00W	white	2 / 3 / 6 mt	NO	PEUHMW

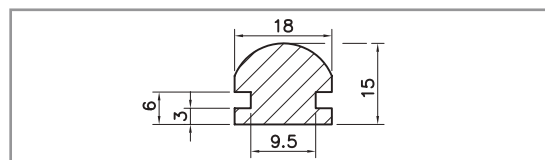

C 30 x 3

CODE	COLOUR	BARS	COILS	MATERIAL
P3030V	green	2 / 3 / 4 mt	NO	PEUHMW
P3030N	black	2 / 3 / 4 mt	NO	PEUHMW

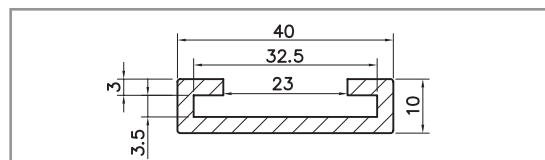

C 40 x 8

CODE	COLOUR	BARS	COILS	MATERIAL
P4080V	green	2 / 3 / 4 mt	NO	PEUHMW
P4080N	black	2 / 3 / 4 mt	NO	PEUHMW

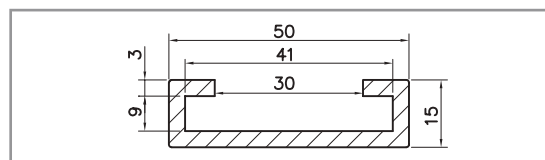

C 50 x 5

CODE	COLOUR	BARS	COILS	MATERIAL
P5050N	black	2 / 3 / 6 mt	NO	PEUHMW

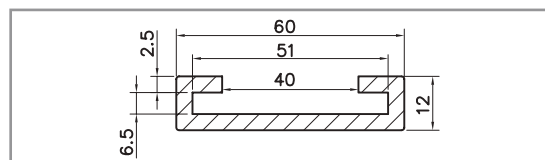

C 50 x 6

CODE	COLOUR	BARS	COILS	MATERIAL
P5060V	green	2 / 3 / 4 mt	NO	PEUHMW
P5060N	black	2 / 3 / 4 mt	NO	PEUHMW

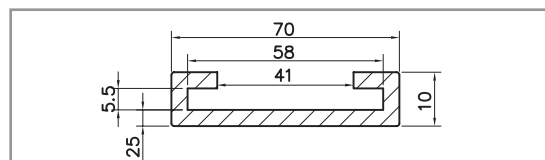

C 70 x 6

CODE	COLOUR	BARS	COILS	MATERIAL
P7060V	green	2 / 3 / 4 mt	NO	PEUHMW
P7060N	black	2 / 3 / 4 mt	NO	PEUHMW

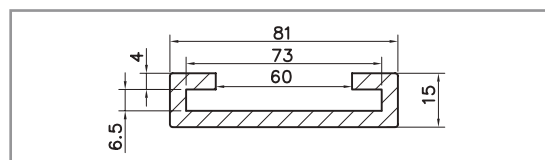

C 43 x 13

CODE	COLOUR	BARS	PACK	MATERIAL
P4313V	green	2 / 3 / 6 mt	36 mt	PEUHMW
P4313N*	black	2 / 3 / 6 mt	36 mt	PEUHMW

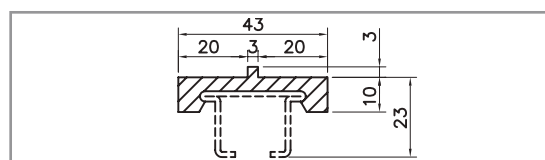

* on request

guide rail profiles for conveyor chains

C 40 x 10

CODE	COLOUR	BARS	MATERIAL
P4010V	green	2 / 3 / 6 mt	PEUHMW
P4010N*	black	2 / 3 / 6 mt	PEUHMW

* on request

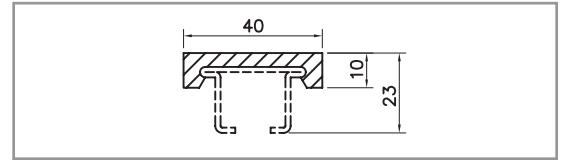

Metal profile OMEGA

CODE	BARS	MATERIAL
M30195	2 / 3 / 6 mt	AISI430
M301955	2 / 3 / 6 mt	AISI304

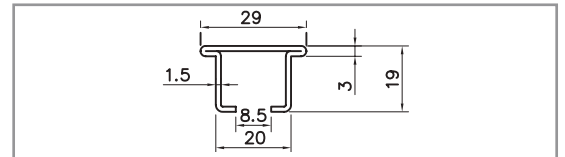

Metal profile

CODE	BARS	A mm	MATERIAL
PM406SS	3 / 6 mt	6	AISI304
PM408SS	3 / 6 mt	8	AISI304
PM4010SS	3 / 6 mt	10	AISI304

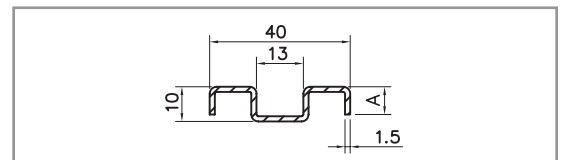

Metal profile 40 x 10

CODE	BARS	A mm	MATERIAL
PM40H8SS	3 / 6 mt	8	AISI304

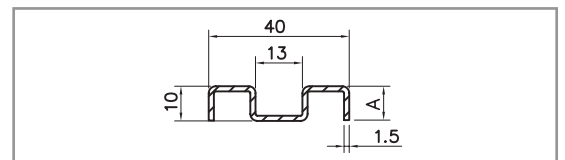

Profile 12

CODE	COLOUR	BARS	PACK	MATERIAL
PR12WS	white	3 / 6 mt	30 mt	PE / ZN
PR12WSS	white	3 / 6 mt	30 mt	PE / AISI304
PR12BS	black	3 / 6 mt	30 mt	PE / ZN
PR12BSS	black	3 / 6 mt	30 mt	PE / AISI304

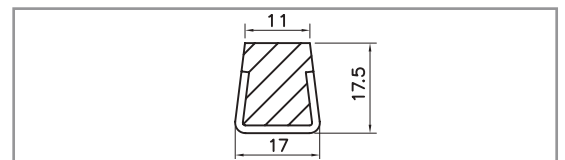

Profile R7

CODE	COLOUR	BARS	PACK	MATERIAL
PR7WS	white	3 / 6 mt	30 mt	PE / ZN
PR7WSS	white	3 / 6 mt	30 mt	PE / AISI304
PR7BS	black	3 / 6 mt	30 mt	PE / ZN
PR7BSS	black	3 / 6 mt	30 mt	PE / AISI304

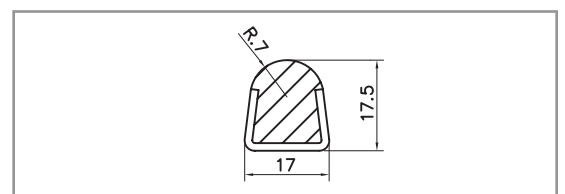

Profile R20

CODE	COLOUR	BARS	PACK	MATERIAL
PR20WS	white	3 / 6 mt	30 mt	PE / ZN
PR20WSS	white	3 / 6 mt	30 mt	PE / AISI304
PR20BS	black	3 / 6 mt	30 mt	PE / ZN
PR20BSS	black	3 / 6 mt	30 mt	PE / AISI304

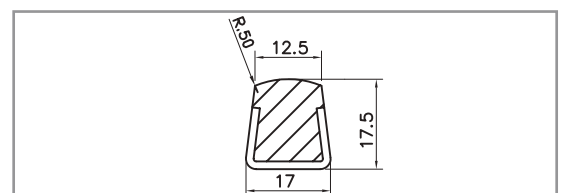

guide rail profiles for conveyor chains

SG - 01

CODE	COLOUR	BARS
PSG10B	blue	2 / 3 / 6 mt
PSG10N	black	2 / 3 / 6 mt

SG - 02

CODE	COLOUR	BARS
PSG20B	blue	2 / 3 / 6 mt
PSG20N	black	2 / 3 / 6 mt

Clamps for SG - 01

CODE	COLOUR
CSG11N	black

minimum 50 pcs

Clamps for SG - 02

CODE	COLOUR
CSG21N	black

minimum 100 pcs

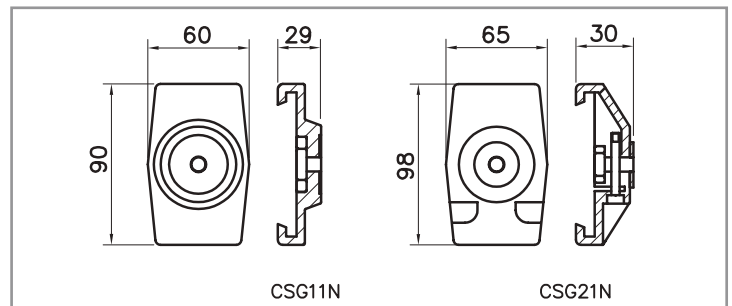
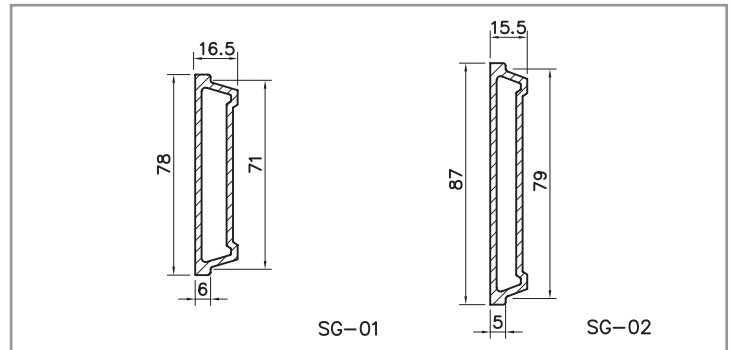

metal profiles

Metal profile C3 / C5 / C9

CODE	A	B	C	d	BARS	MATERIAL
MC3S	20	10	10	1.5	2 / 3 / 6 mt	ZnplSt
MC3SS	20	10	10	1.5	2 / 3 / 6 mt	AISI304
MC5S	28	14	14	1.5	2 / 3 / 6 mt	ZnplSt
MC5SS	28	14	14	1.5	2 / 3 / 6 mt	AISI304
MC9S	38	22	22	1.5	2 / 3 / 6 mt	ZnplSt
MC9SS	38	22	22	1.5	2 / 3 / 6 mt	AISI304

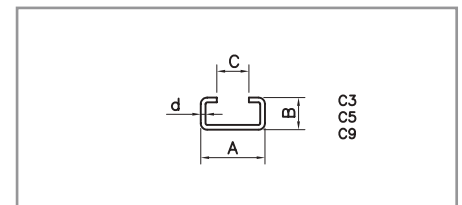

Metal profile C10 / C11

CODE	A	B	C	d	BARS	MATERIAL
MC10S	30	24	20	1.5	2 / 3 / 6 mt	ZnplSt
MC10SS	30	24	20	1.5	2 / 3 / 6 mt	AISI304
MC11S	45	40	31	1.5	2 / 3 / 6 mt	ZnplSt
MC11SS	45	40	31	1.5	2 / 3 / 6 mt	AISI304

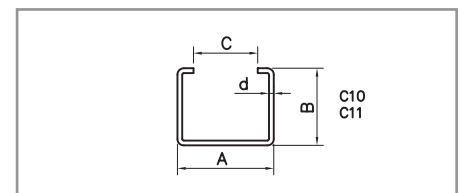

Metal profile C14 / C15

CODE	A	B	C	d	BARS	MATERIAL
MC14S	31	25	20	2.0	2 / 3 / 6 mt	ZnplSt
MC14SS	31	25	20	2.0	2 / 3 / 6 mt	AISI304
MC15S	31	25	20	2.0	2 / 3 / 6 mt	ZnplSt
MC15SS	31	25	20	2.0	2 / 3 / 6 mt	AISI304

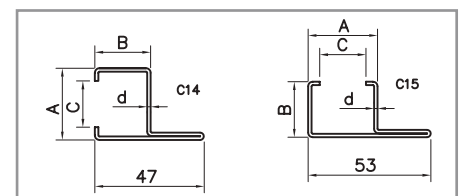

conveyor belts

Example of a conveyor belt with chain return guides.

It's important to provide a gap for the catenary sag under the sprockets, in order to avoid excessive tension on the hinges and to make an eventual chain disassembly easier. The chain return occurs on guides in self-lubricating material (PEUHMW or Nylatron); the chain entry radius should be anyway greater than the backflex radius (Rd).

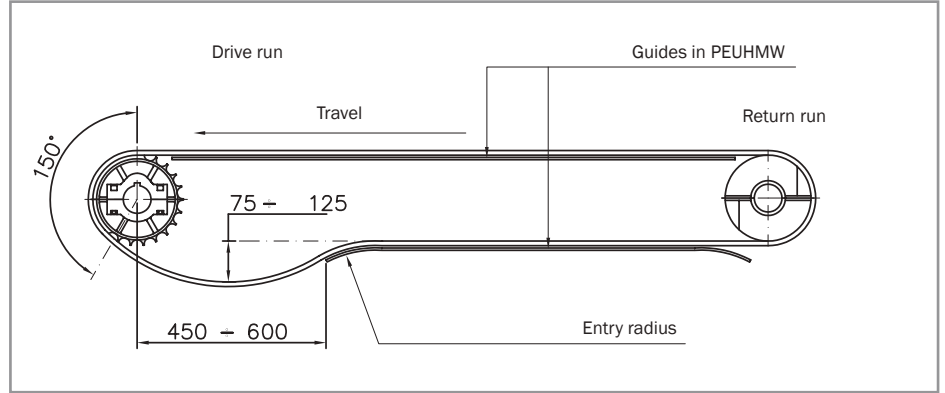

Example of a conveyor belt with chain return rollers.

It's important to provide a gap for the catenary sag under the sprockets, in order to avoid excessive tension on the hinges and to make an eventual chain disassembly easier. Chain return rollers should have a diameter corresponding at least to twice the dimension of the chain backflex radius (Rd).

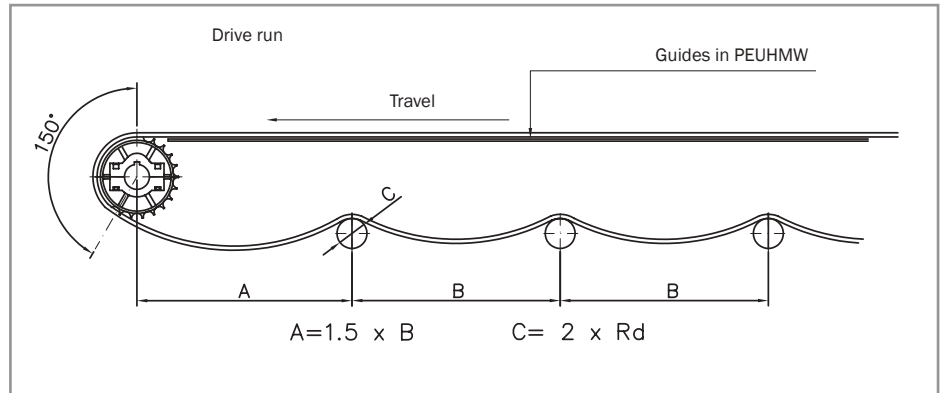

conveyor design

A few examples of slide guide assembly according to chain type are hereunder represented.

It's important to remember that for narrow-base products or products conveyed on more tracks the fundamental value is chain distance (Gap). The lower this value is, the less unstable the conveyed product becomes.

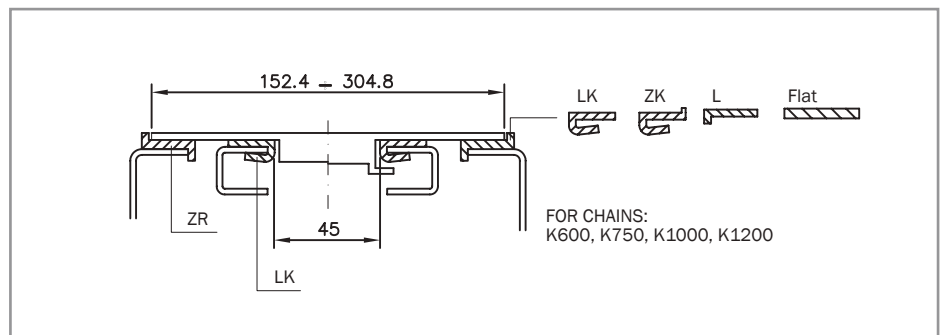
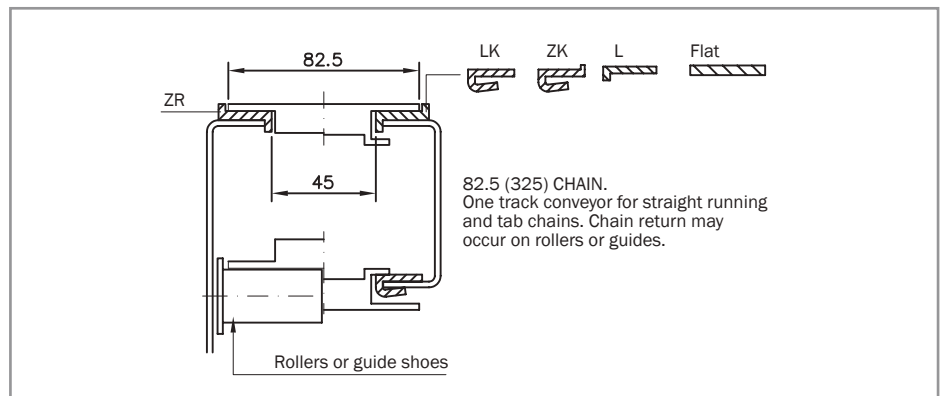

conveyor design

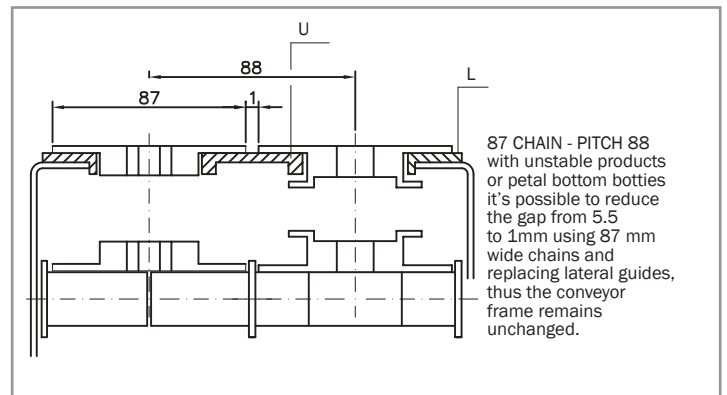
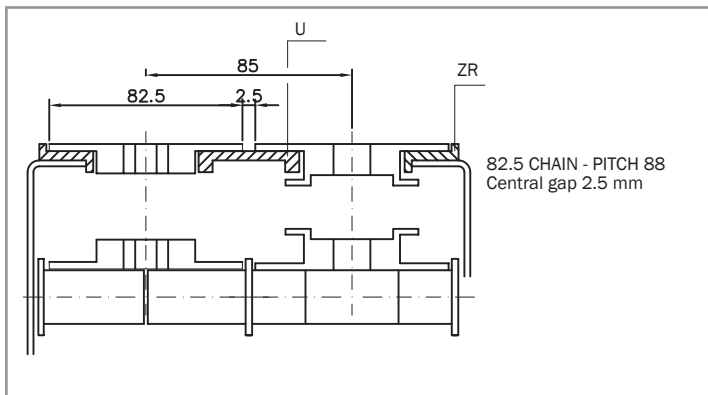
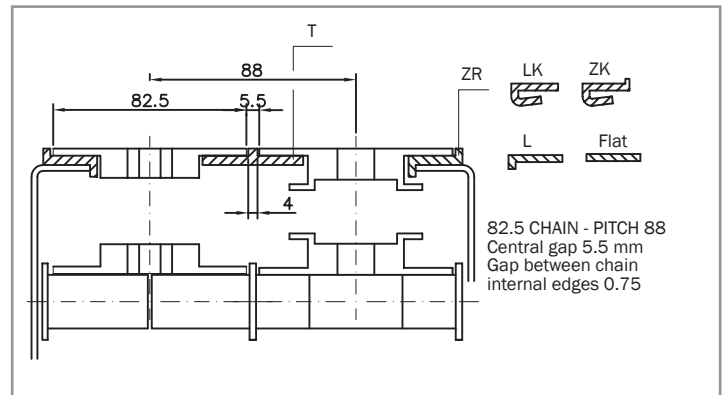
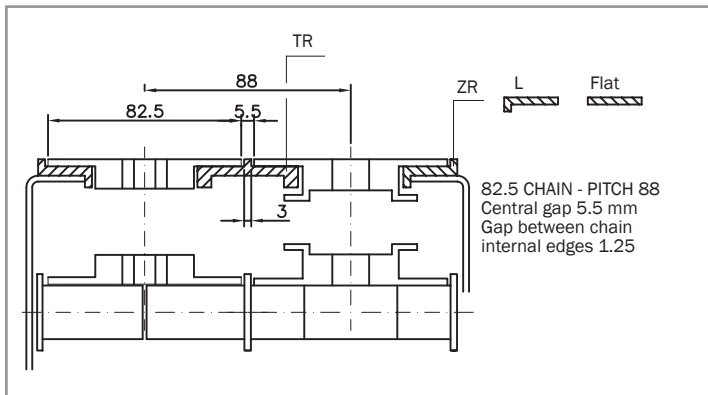
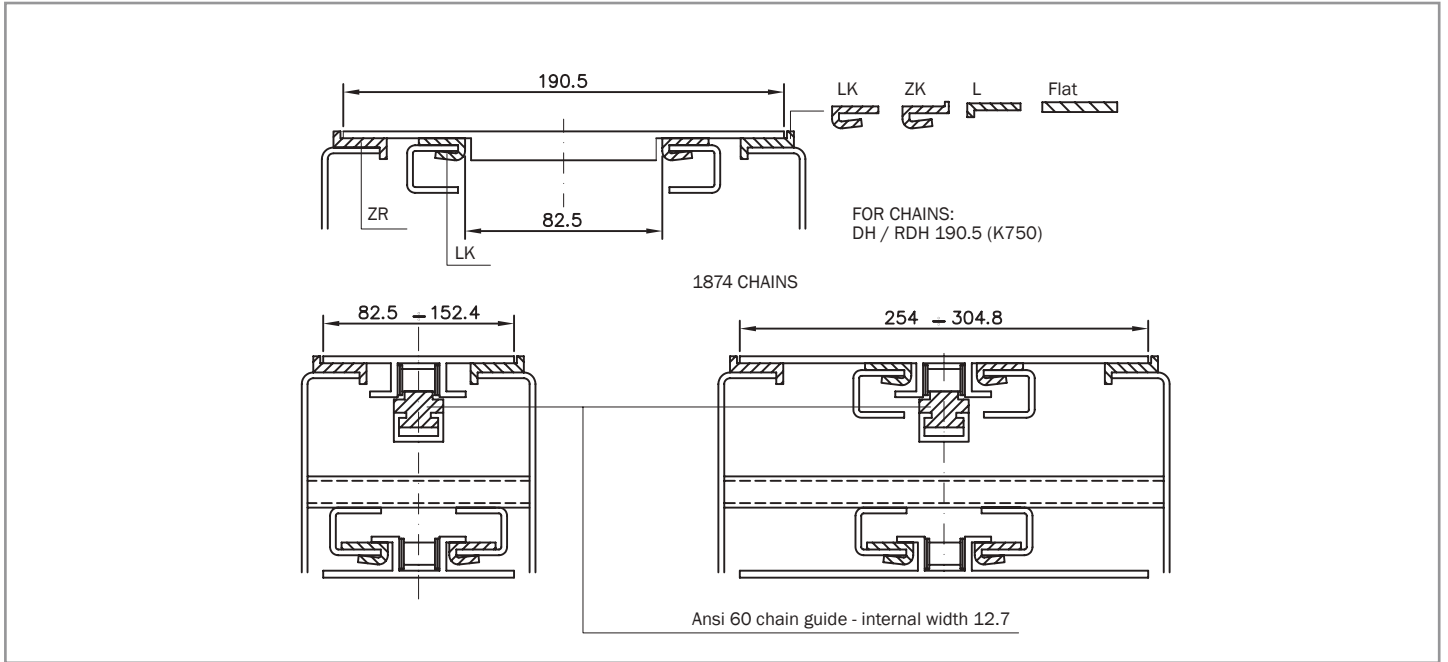

Алматы (727)345-47-04
Ангарск (3955)60-70-56
Архангельск (8182)63-90-72
Астрахань (8512)99-46-04
Барнаул (3852)73-04-60
Белгород (4722)40-23-64
Благовещенск (4162)22-76-07
Брянск (4832)59-03-52
Владивосток (423)249-28-31
Владикавказ (8672)28-90-48
Владимир (4922)49-43-18
Волгоград (844)278-03-48
Вологда (8172)26-41-59
Воронеж (473)204-51-73
Екатеринбург (343)384-55-89

Иваново (4932)77-34-06
Ижевск (3412)26-03-58
Иркутск (395)279-98-46
Казань (843)206-01-48
Калининград (4012)72-03-81
Калуга (4842)92-23-67
Кемерово (3842)65-04-62
Киров (8332)68-02-04
Коломна (4966)23-41-49
Кострома (4942)77-07-48
Краснодар (861)203-40-90
Красноярск (391)204-63-61
Курск (4712)77-13-04
Курган (3522)50-90-47
Липецк (4742)52-20-81

Магнитогорск (3519)55-03-13
Москва (495)268-04-70
Мурманск (8152)59-64-93
Набережные Челны (8552)20-53-41
Нижний Новгород (831)429-08-12
Новокузнецк (3843)20-46-81
Ноябрьск (3496)41-32-12
Новосибирск (383)227-86-73
Омск (3812)21-46-40
Орел (4862)44-53-42
Оренбург (3532)37-68-04
Пенза (8412)22-31-16
Петрозаводск (8142)55-98-37
Псков (8112)59-10-37
Пермь (342)205-81-47

Ростов-на-Дону (863)308-18-15
Рязань (4912)46-61-64
Самара (846)206-03-16
Санкт-Петербург (812)309-46-40
Саратов (845)249-38-78
Севастополь (8692)22-31-93
Саранск (8342)22-96-24
Симферополь (3652)67-13-56
Смоленск (4812)29-41-54
Сочи (862)225-72-31
Ставрополь (8652)20-65-13
Сургут (3462)77-98-35
Сыктывкар (8212)25-95-17
Тамбов (4752)50-40-97
Тверь (4822)63-31-35

Тольятти (8482)63-91-07
Томск (3822)98-41-53
Тула (4872)33-79-87
Тюмень (3452)66-21-18
Ульяновск (8422)24-23-59
Улан-Удэ (3012)59-97-51
Уфа (347)229-48-12
Хабаровск (4212)92-98-04
Чебоксары (8352)28-53-07
Челябинск (351)202-03-61
Череповец (8202)49-02-64
Чита (3022)38-34-83
Якутск (4112)23-90-97
Ярославль (4852)69-52-93

Россия +7(495)268-04-70

Казахстан +7(727)345-47-04

Беларусь +3(257)257-127-884

Узбекистан +998(71)205-18-59

Киргизия +996(312)96-26-47