

Food Industries

Алматы (727)345-47-04
Ангарск (3955)60-70-56
Архангельск (8182)63-90-72
Астрахань (8512)99-46-04
Барнаул (3852)73-04-60
Белгород (4722)40-23-64
Благовещенск (4162)22-76-07
Брянск (4832)59-03-52
Владивосток (423)249-28-31
Владикавказ (8672)28-90-48
Владимир (4922)49-43-18
Волгоград (844)278-03-48
Вологда (8172)26-41-59
Воронеж (473)204-51-73
Екатеринбург (343)384-55-89

Иваново (4932)77-34-06
Ижевск (3412)26-03-58
Иркутск (395)279-98-46
Казань (843)206-01-48
Калининград (4012)72-03-81
Калуга (4842)92-23-67
Кемерово (3842)65-04-62
Киров (8332)68-02-04
Копомна (4966)23-41-49
Кострома (4942)77-07-48
Краснодар (861)203-40-90
Красноярск (391)204-63-61
Курск (4712)77-13-04
Курган (3522)50-90-47
Липецк (4742)52-20-81

Магнитогорск (3519)55-03-13
Москва (495)268-04-70
Мурманск (8152)59-64-93
Набережные Челны (8552)20-53-41
Нижний Новгород (831)429-08-12
Новокузнецк (3843)20-46-81
Новыйбурск (3496)41-32-12
Новосибирск (383)227-86-73
Омск (3812)21-46-40
Орел (4862)44-53-42
Оренбург (3532)37-68-04
Пенза (8412)22-31-16
Петрозаводск (8142)55-98-37
Псков (8112)59-10-37
Пермь (342)205-81-47

Ростов-на-Дону (863)308-18-15
Рязань (4912)46-61-64
Самара (846)206-03-16
Санкт-Петербург (812)309-46-40
Саратов (845)249-38-78
Севастополь (8692)22-31-93
Саранск (8342)22-96-24
Симферополь (3652)67-13-56
Смоленск (4812)29-41-54
Сочи (862)225-72-31
Ставрополь (8652)20-65-13
Сургут (3462)77-98-35
Сыктывкар (8212)25-95-17
Тамбов (4752)50-40-97
Тверь (4822)63-31-35

Тольятти (8482)63-91-07
Томск (3822)98-41-53
Тула (4872)33-79-87
Тюмень (3452)66-21-18
Ульяновск (8422)24-23-59
Улан-Удэ (3012)59-97-51
Уфа (347)229-48-12
Хабаровск (4212)92-98-04
Чебоксары (8352)28-53-07
Челябинск (351)202-03-61
Череповец (8202)49-02-64
Чита (3022)38-34-83
Якутск (4112)23-90-97
Ярославль (4852)69-52-93

Россия +7(495)268-04-70

Казахстан +7(727)345-47-04

Беларусь +(375)257-127-884

Узбекистан +998(71)205-18-59

Киргизия +996(312)96-26-47

<https://magris.nt-rt.ru/> || mgq@nt-rt.ru

magnetic corner tracks



flat carrying surface

Magnetic curve is ideal solution for your corners. Special integrated permanent magnets keep the chain in the curve. This system offers a flat carrying surface, therefore the best product stability and support. The complete curve consists of an upper part with magnets and a separate return part mounted together. The return infeed shoe will ensure smooth guiding of the chains into the return section.

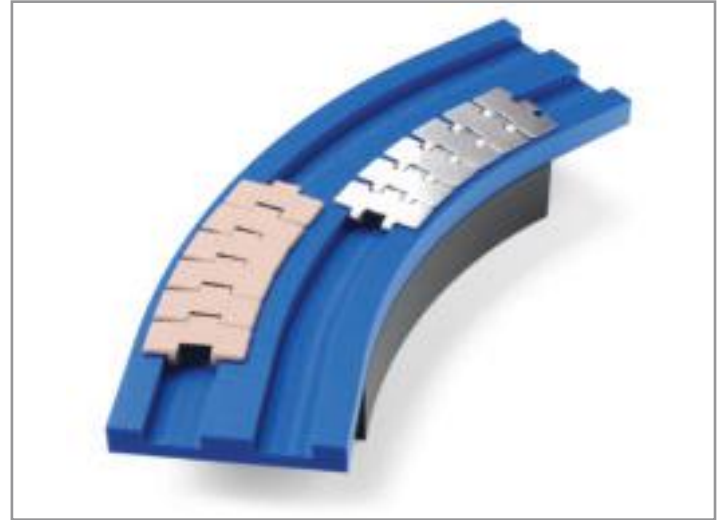

longer wearlife

Magnetic chains are also flatter since they have no tabs guides. Clearing the curve can be done easily by lifting the chain. The curve surface is closed and smooth to avoid dirt accumulation. This system provides a longer wearlife, because the bearing surface of the chains on the curve is larger than in other systems, the maintenance is easier.



P8000 - special compound of PE-UHMW

BENEFITS & FEATURES

- Special material for very high speed applications.
- Extremely low coefficient of friction.
- Reduced chain pull. Reduced noise and squeaking.
- Reduced the consumption of energy.

** Worldwide no restrictions for Magris magnetic curves used with stainless steel chains.

** Some restrictions in specific countries for Magris magnetic curves used with thermoplastic chains.
Please contact our Customer Service for more details.

magnetic corner tracks

SELECTION TABLES

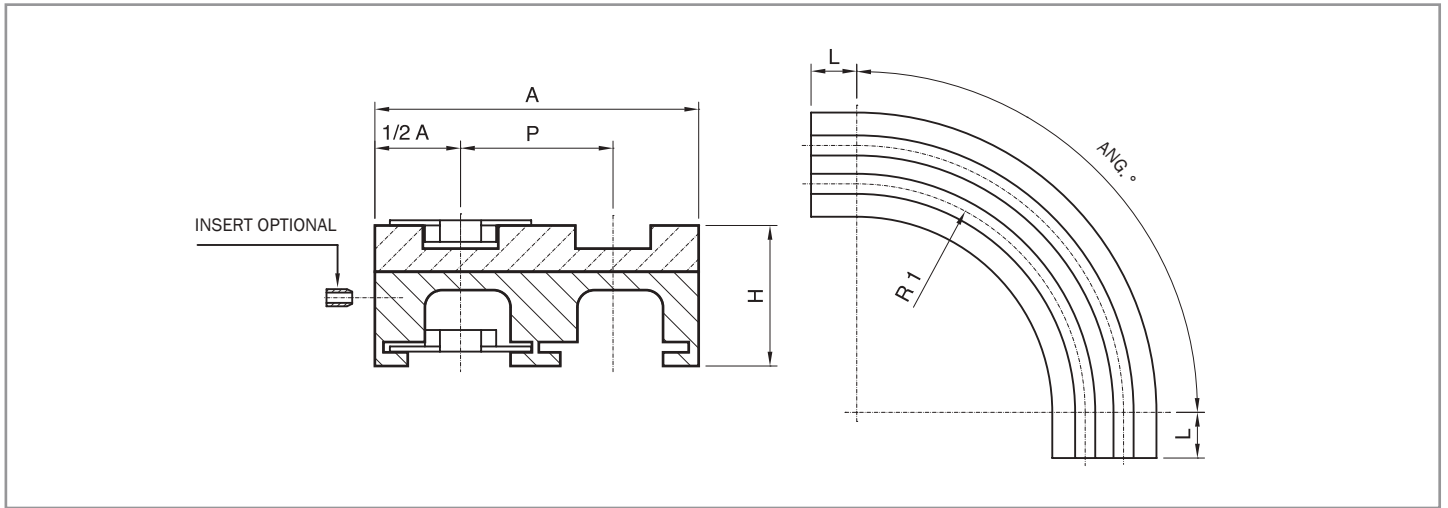

SELECTION TABLES

Chains			Radius R	Pitch P	Basic Width A	Infeed Length L	Total Height H	Version	Page			
chains ref.	thickness	hinge										
for Chains with K325 - K330 Plate Width												
879 M K325 880 M K325 880 M K330 8811 M K325 8811 M K330 581 M K325	3 - 4	42,1	500	85	100	0	82 / 90	CM07	108			
					110	100	90	CM06	108			
					111			CM10	109			
				89	100	82	CM04	109				
				90	100		CM14	110				
				90	110		CM01	110				
			590	180	100	100	0	82	CM02	111		
			680	-					CM03	111		
			750	85	100	100	0	82 / 90	CM05B	112		
			860	-				111	90	82	CM05A	112
								110			CM08	113
			1000	-	100	100	125	82	CM09	114		
0	CM05C	114										
	100	CM05D							115			
85	111	100	90	CM43	115							
for Chains with K325 - K450 Plate Width												
661 M K325 661 M K330	3	42,2	500	85	100	100	82	CMF06	116			
879 M K450 880 M K450 8811 M K450	3 - 4	42,1		610	120	129	125	90	CM21A	116		
117			0		CM22A				117			
											CM27	117

selection tables

SELECTION TABLES

Chains			Radius R	Pitch P	Basic Width A	Infeed Length L	Total Height H	Version	Page		
chains ref.	thickness	hinge									
for Chains with K750 - Plate Width											
880 M K750 8811 M K750	3 - 4	42,1	500	192	214	0	90	CM60	118		
			610	196		125		CM61	118		
			750	-		0	82	CM62	119		
			860					CM66	119		
			1000					CM65	120		
8817 M K750 8817 M G K750 882 M K750	3 - 4,8	42,1	610	195	200	100	95	CM81	120		
		56,6	750				87 / 95	CM85	121		
		57	860	-	214	0	87	CM86	121		
			1000	195	200	100	87 / 95	CM80	122		
for Chains with K1000 - Plate Width											
882 M K1000	4,8	56,6	860	-	290	0	87	CM91	122		
			1000				270	95	CM93	123	
for Chains with K1200 - Plate Width											
882 M K1200	4,8	56,6	860	-	340	0	87	CM96	124		
			1000		320		95	CM97	124		
for LBP Chains Series											
LBP 879 M K325	4,8	56,6	500	85	100	0	82 / 102	CMP68C	125		
LBP 882 M K325				90		100	90	CMP02	126		
LBP 882 M K750			-	214	860	200	0	95	CMP861	126	
						-			270	CMP86C	127
									290	CMP93C	127
LBP 882 M K1000			-	270	1000	270	0	95	CMP91	128	
290						CMP94C			128		
LBP 882 M K1200			-	320	860	320	0	95	CMP97C	129	
						340			CMP96	129	
1000			320	CMP98C	130						
for 780M - 790M - Chains Series											
780 M K330	8,7	42,1	500	85	100	100	90	CMB06	130		
					111	0	82 / 90	CMB07	131		
			750		100	90	CMB04	131			
			1000		0		CMB08	132			
780 M K450	-	-	500	117	129	100	CMB05D	132			
			610		100	CMB22	133				
790 M K330	12,7	42,1	500	85	100	100	90	CMB27	133		
					111	0	82 / 90	CMC06	134		
			750		100	90	CMC07	134			
			1000		0		CMC04	135			
790 M K450	-	-	500	120	125	100	90	CMC08	135		
			610		117	129	100	CMC05D	136		
			500	120	125	100	CMC21	136			
610	117	100	100	CMC22	137						
									CMC27	137	
RETURN GUIDE SHOES: INSTALLATION									138		

magnetic corner tracks

VERSION CM07 / CM06

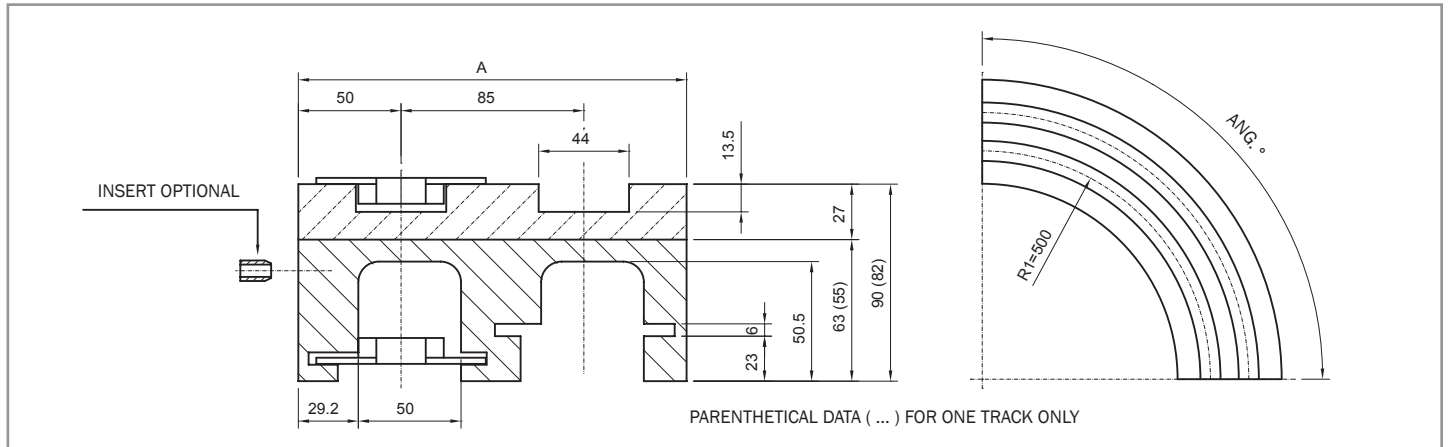

VERSION CM07

Nr. of Tracks	A	Curve angle 15°	Curve angle 30°	Curve angle 45°	Curve angle 60°	Curve angle 75°	Curve angle 90°
1	100	CM07 01 15	CM07 01 30	CM07 01 45	CM07 01 60	CM07 01 75	CM07 01 90
2	185	CM07 02 15	CM07 02 30	CM07 02 45	CM07 02 60	CM07 02 75	CM07 02 90
3	270	CM07 03 15	CM07 03 30	CM07 03 45	CM07 03 60	CM07 03 75	CM07 03 90
4	355	CM07 04 15	CM07 04 30	CM07 04 45	CM07 04 60	CM07 04 75	CM07 04 90
5	440	CM07 05 15	CM07 05 30	CM07 05 45	CM07 05 60	CM07 05 75	CM07 05 90
6	525	CM07 06 15	CM07 06 30	CM07 06 45	CM07 06 60	CM07 06 75	CM07 06 90
7	610	CM07 07 15	CM07 07 30	CM07 07 45	CM07 07 60	CM07 07 75	CM07 07 90

CHAINS REF.

879 M K325
880 M K325
880 M K330
8811 M K325
8811 M K330
581 M K325

More than 7 tracks on request.

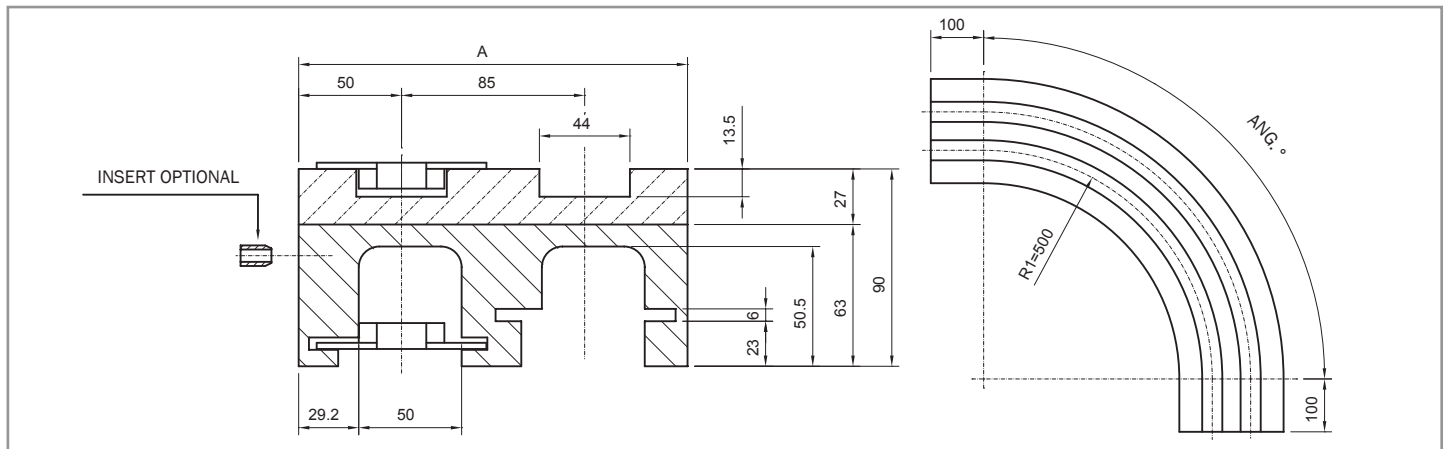

VERSION CM06

Nr. of Tracks	A	Curve angle 15°	Curve angle 30°	Curve angle 45°	Curve angle 60°	Curve angle 75°	Curve angle 90°
1	100	CM06 01 15	CM06 01 30	CM06 01 45	CM06 01 60	CM06 01 75	CM06 01 90
2	185	CM06 02 15	CM06 02 30	CM06 02 45	CM06 02 60	CM06 02 75	CM06 02 90
3	270	CM06 03 15	CM06 03 30	CM06 03 45	CM06 03 60	CM06 03 75	CM06 03 90
4	355	CM06 04 15	CM06 04 30	CM06 04 45	CM06 04 60	CM06 04 75	CM06 04 90
5	440	CM06 05 15	CM06 05 30	CM06 05 45	CM06 05 60	CM06 05 75	CM06 05 90
6	525	CM06 06 15	CM06 06 30	CM06 06 45	CM06 06 60	CM06 06 75	CM06 06 90
7	610	CM06 07 15	CM06 07 30	CM06 07 45	CM06 07 60	CM06 07 75	CM06 07 90

CHAINS REF.

879 M K325
880 M K325
880 M K330
8811 M K325
8811 M K330
581 M K325

More than 7 tracks on request.

magnetic corner tracks

VERSION CM10 / CM04

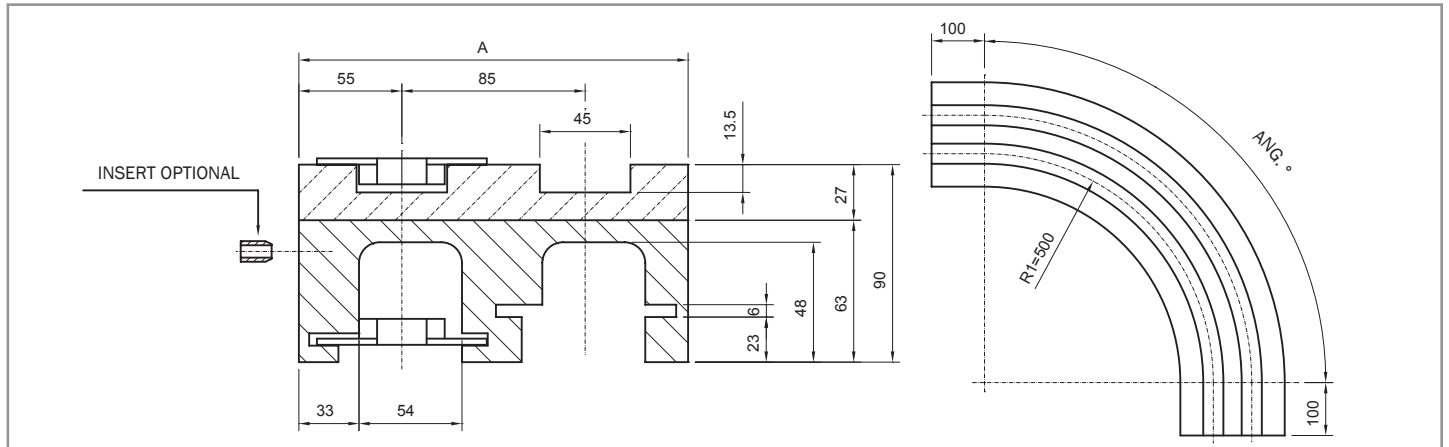

VERSION CM10

Nr. of Tracks	A	Curve angle 15°	Curve angle 30°	Curve angle 45°	Curve angle 60°	Curve angle 75°	Curve angle 90°
1	100	CM10 01 15	CM10 01 30	CM10 01 45	CM10 01 60	CM10 01 75	CM10 01 90
2	195	CM10 02 15	CM10 02 30	CM10 02 45	CM10 02 60	CM10 02 75	CM10 02 90
3	280	CM10 03 15	CM10 03 30	CM10 03 45	CM10 03 60	CM10 03 75	CM10 03 90
4	365	CM10 04 15	CM10 04 30	CM10 04 45	CM10 04 60	CM10 04 75	CM10 04 90
5	450	CM10 05 15	CM10 05 30	CM10 05 45	CM10 05 60	CM10 05 75	CM10 05 90
6	535	CM10 06 15	CM10 06 30	CM10 06 45	CM10 06 60	CM10 06 75	CM10 06 90
7	620	CM10 07 15	CM10 07 30	CM10 07 45	CM10 07 60	CM10 07 75	CM10 07 90
8	705	CM10 08 15	CM10 08 30	CM10 08 45	CM10 08 60	CM10 08 75	CM10 08 90

CHAINS REF.

- 879 M K325
- 880 M K325
- 880 M K330
- 8811 M K325
- 8811 M K330
- 581 M K325

More than 8 tracks on request.

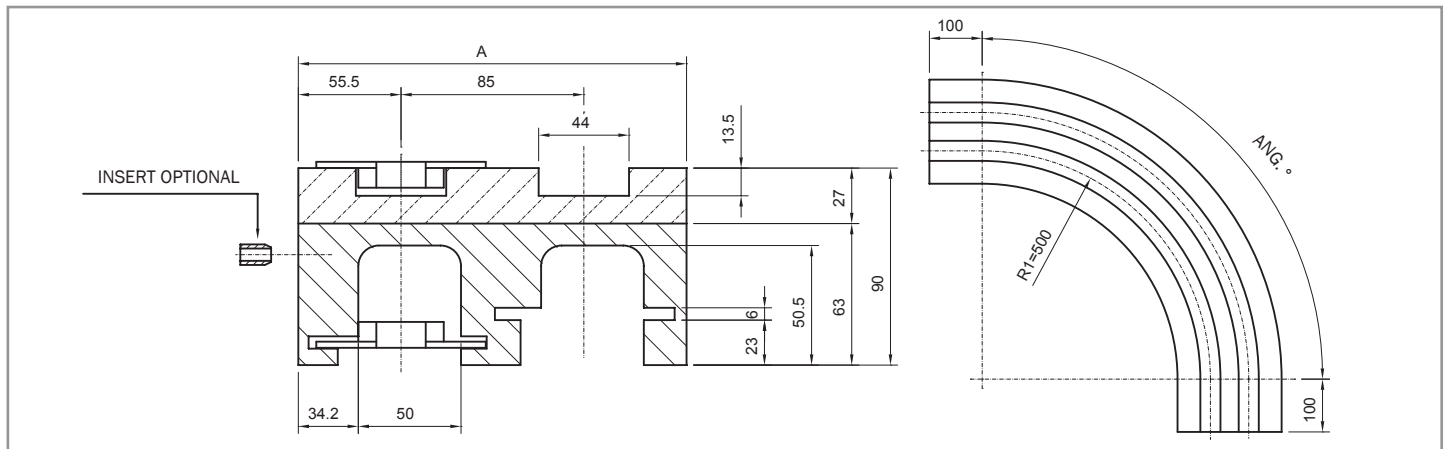

VERSION CM04

Nr. of Tracks	A	Curve angle 15°	Curve angle 30°	Curve angle 45°	Curve angle 60°	Curve angle 75°	Curve angle 90°
1	111	CM04 01 15	CM04 01 30	CM04 01 45	CM04 01 60	CM04 01 75	CM04 01 90
2	196	CM04 02 15	CM04 02 30	CM04 02 45	CM04 02 60	CM04 02 75	CM04 02 90
3	281	CM04 03 15	CM04 03 30	CM04 03 45	CM04 03 60	CM04 03 75	CM04 03 90
4	366	CM04 04 15	CM04 04 30	CM04 04 45	CM04 04 60	CM04 04 75	CM04 04 90
5	451	CM04 05 15	CM04 05 30	CM04 05 45	CM04 05 60	CM04 05 75	CM04 05 90
6	536	CM04 06 15	CM04 06 30	CM04 06 45	CM04 06 60	CM04 06 75	CM04 06 90
7	621	CM04 07 15	CM04 07 30	CM04 07 45	CM04 07 60	CM04 07 75	CM04 07 90

CHAINS REF.

- 879 M K325
- 880 M K325
- 880 M K330
- 8811 M K325
- 8811 M K330
- 581 M K325

More than 7 tracks on request.

magnetic corner tracks

VERSION CM14 / CM01

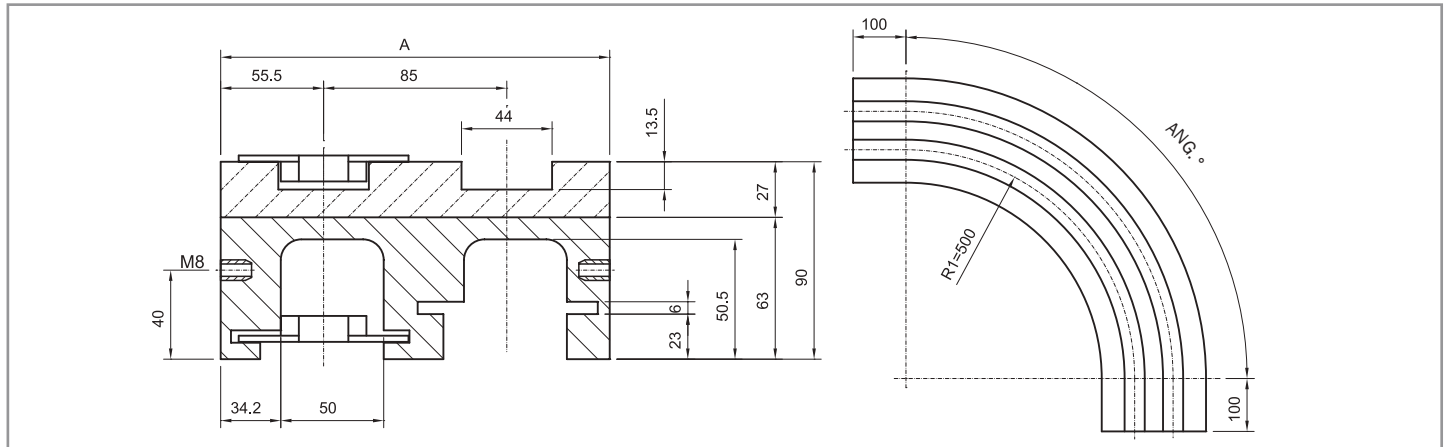

VERSION CM14

Nr. of Tracks	A	Curve angle 15°	Curve angle 30°	Curve angle 45°	Curve angle 60°	Curve angle 75°	Curve angle 90°
1	111	CM14 01 15	CM14 01 30	CM14 01 45	CM14 01 60	CM14 01 75	CM14 01 90
2	196	CM14 02 15	CM14 02 30	CM14 02 45	CM14 02 60	CM14 02 75	CM14 02 90
3	281	CM14 03 15	CM14 03 30	CM14 03 45	CM14 03 60	CM14 03 75	CM14 03 90
4	366	CM14 04 15	CM14 04 30	CM14 04 45	CM14 04 60	CM14 04 75	CM14 04 90
5	451	CM14 05 15	CM14 05 30	CM14 05 45	CM14 05 60	CM14 05 75	CM14 05 90
6	536	CM14 06 15	CM14 06 30	CM14 06 45	CM14 06 60	CM14 06 75	CM14 06 90
7	621	CM14 07 15	CM14 07 30	CM14 07 45	CM14 07 60	CM14 07 75	CM14 07 90

CHAINS REF.

879 M K325
880 M K325
880 M K330
8811 M K325
8811 M K330
581 M K325

More than 7 tracks on request.
Include inserts, of which the pattern varies per angle.

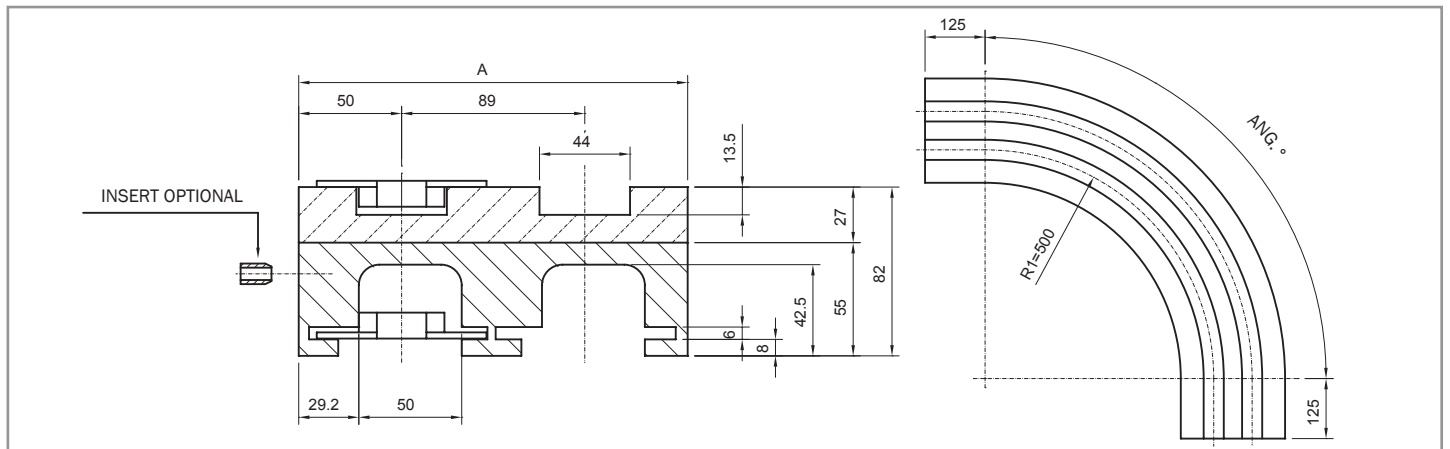

VERSION CM01

Nr. of Tracks	A	Curve angle 15°	Curve angle 30°	Curve angle 45°	Curve angle 60°	Curve angle 75°	Curve angle 90°
1	100	CM01 01 15	CM01 01 30	CM01 01 45	CM01 01 60	CM01 01 75	CM01 01 90
2	189	CM01 02 15	CM01 02 30	CM01 02 45	CM01 02 60	CM01 02 75	CM01 02 90
3	278	CM01 03 15	CM01 03 30	CM01 03 45	CM01 03 60	CM01 03 75	CM01 03 90
4	367	CM01 04 15	CM01 04 30	CM01 04 45	CM01 04 60	CM01 04 75	CM01 04 90
5	456	CM01 05 15	CM01 05 30	CM01 05 45	CM01 05 60	CM01 05 75	CM01 05 90
6	545	CM01 06 15	CM01 06 30	CM01 06 45	CM01 06 60	CM01 06 75	CM01 06 90
7	634	CM01 07 15	CM01 07 30	CM01 07 45	CM01 07 60	CM01 07 75	CM01 07 90

CHAINS REF.

879 M K325
880 M K325
880 M K330
8811 M K325
8811 M K330
581 M K325

More than 7 tracks on request.

magnetic corner tracks

VERSION CM02 / CM03

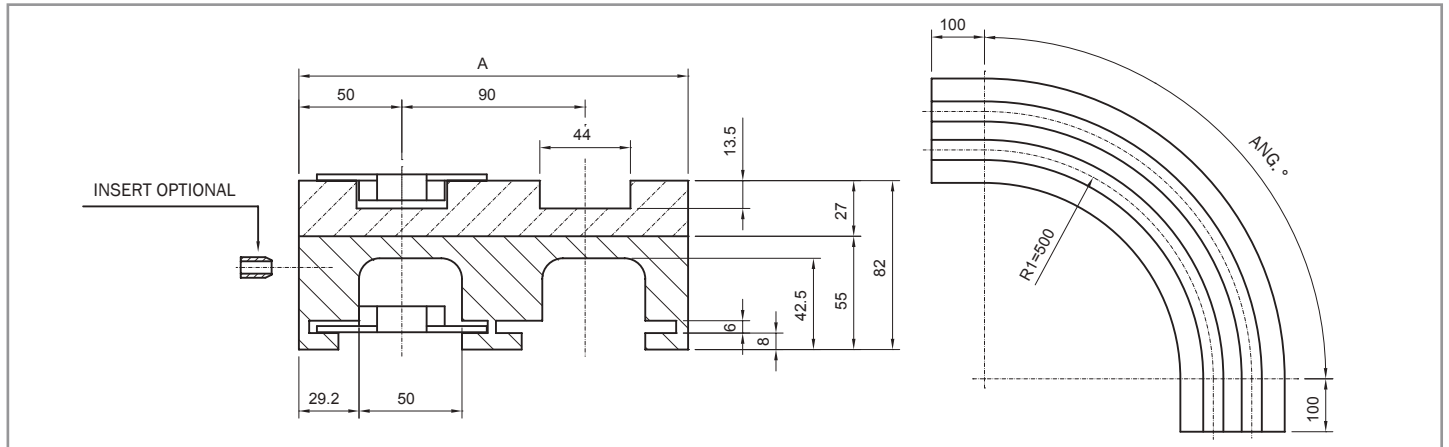

VERSION CM02

Nr. of Tracks	A	Curve angle					
		15°	30°	45°	60°	75°	90°
1	100	CM02 01 15	CM02 01 30	CM02 01 45	CM02 01 60	CM02 01 75	CM02 01 90
2	190	CM02 02 15	CM02 02 30	CM02 02 45	CM02 02 60	CM02 02 75	CM02 02 90
3	280	CM02 03 15	CM02 03 30	CM02 03 45	CM02 03 60	CM02 03 75	CM02 03 90
4	370	CM02 04 15	CM02 04 30	CM02 04 45	CM02 04 60	CM02 04 75	CM02 04 90
5	460	CM02 05 15	CM02 05 30	CM02 05 45	CM02 05 60	CM02 05 75	CM02 05 90
6	550	CM02 06 15	CM02 06 30	CM02 06 45	CM02 06 60	CM02 06 75	CM02 06 90
7	640	CM02 07 15	CM02 07 30	CM02 07 45	CM02 07 60	CM02 07 75	CM02 07 90

CHAINS REF.

- 879 M K325
- 880 M K325
- 880 M K330
- 8811 M K325
- 8811 M K330
- 581 M K325

More than 7 tracks on request.

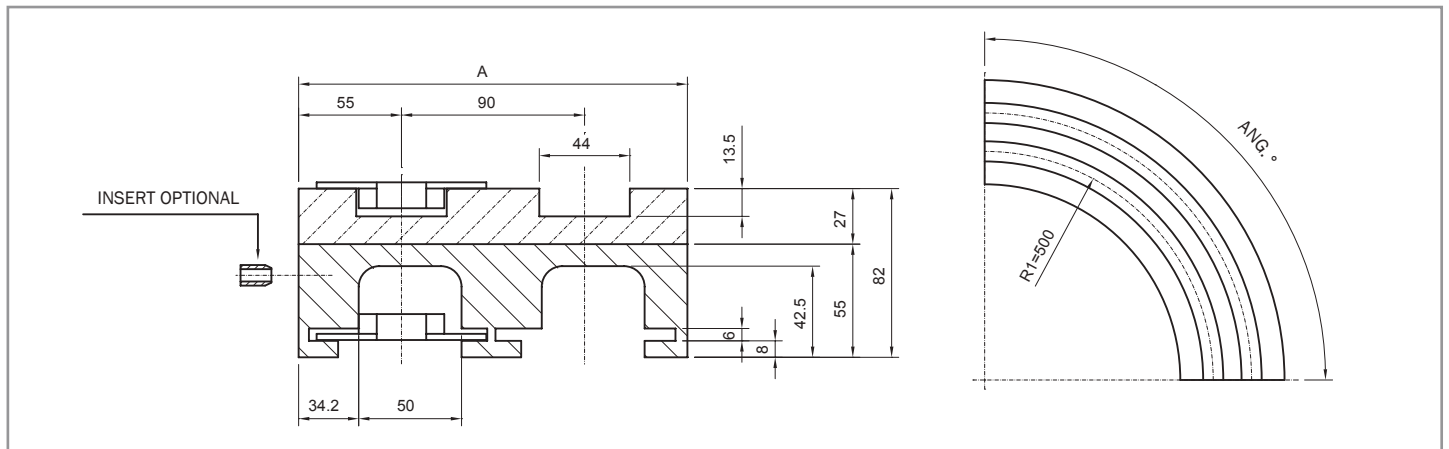

VERSION CM03

Nr. of Tracks	A	Curve angle					
		15°	30°	45°	60°	75°	90°
1	110	CM03 01 15	CM03 01 30	CM03 01 45	CM03 01 60	CM03 01 75	CM03 01 90
2	200	CM03 02 15	CM03 02 30	CM03 02 45	CM03 02 60	CM03 02 75	CM03 02 90
3	290	CM03 03 15	CM03 03 30	CM03 03 45	CM03 03 60	CM03 03 75	CM03 03 90
4	380	CM03 04 15	CM03 04 30	CM03 04 45	CM03 04 60	CM03 04 75	CM03 04 90
5	470	CM03 05 15	CM03 05 30	CM03 05 45	CM03 05 60	CM03 05 75	CM03 05 90
6	560	CM03 06 15	CM03 06 30	CM03 06 45	CM03 06 60	CM03 06 75	CM03 06 90
7	650	CM03 07 15	CM03 07 30	CM03 07 45	CM03 07 60	CM03 07 75	CM03 07 90

CHAINS REF.

- 879 M K325
- 880 M K325
- 880 M K330
- 8811 M K325
- 8811 M K330
- 581 M K325

More than 7 tracks on request.

magnetic corner tracks

VERSION CM05B / CM05A

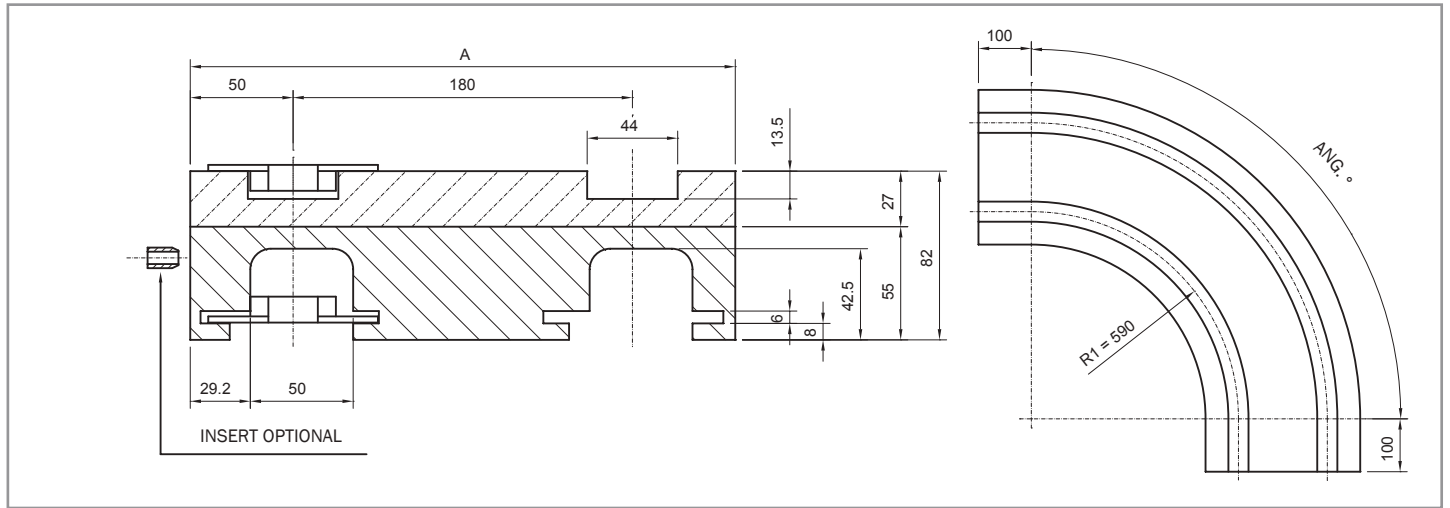

VERSION CM05B

Nr. of Tracks	A	Curve angle 15°	Curve angle 30°	Curve angle 45°	Curve angle 60°	Curve angle 75°	Curve angle 90°
2	280	CM05B 02 15	CM05B 02 30	CM05B 02 45	CM05B 02 60	CM05B 02 75	CM05B 02 90

Special twin-track design for crate conveyors.

CHAINS REF.

879 M K325
880 M K325
880 M K330
8811 M K325
8811 M K330
581 M K325

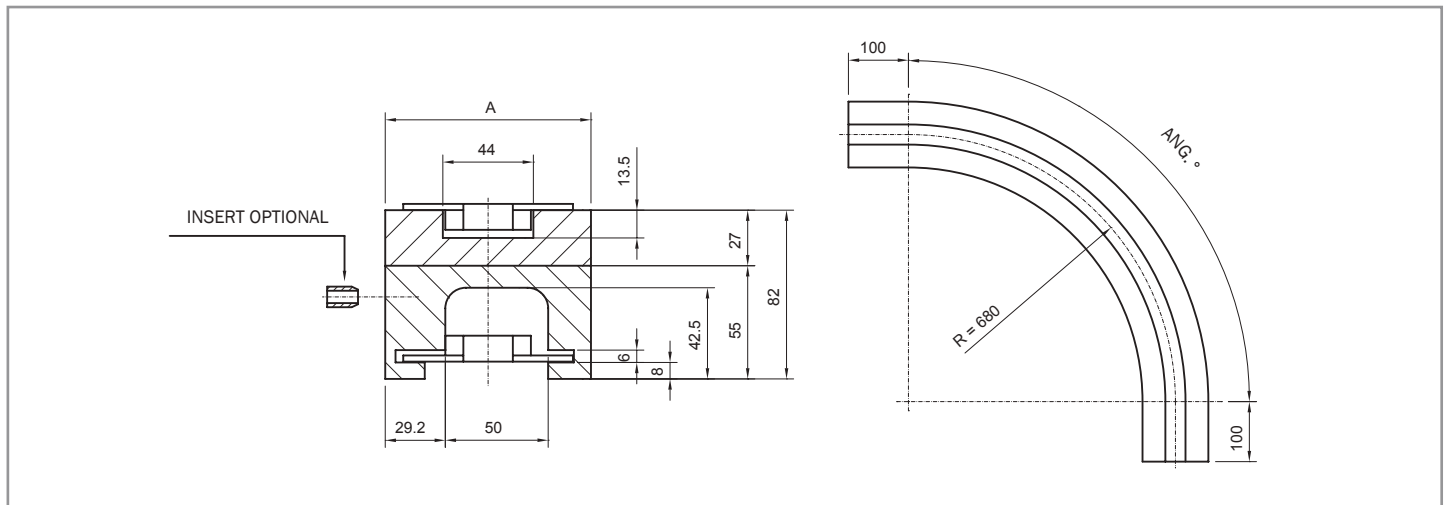

VERSION CM05A

Nr. of Tracks	A	Curve angle 15°	Curve angle 30°	Curve angle 45°	Curve angle 60°	Curve angle 75°	Curve angle 90°
1	100	CM05A 01 15	CM05A 01 30	CM05A 01 45	CM05A 01 60	CM05A 01 75	CM05A 01 90

More than 1 track on request.

CHAINS REF.

879 M K325
880 M K325
880 M K330
8811 M K325
8811 M K330
581 M K325

magnetic corner tracks

VERSION CM08 / CM42

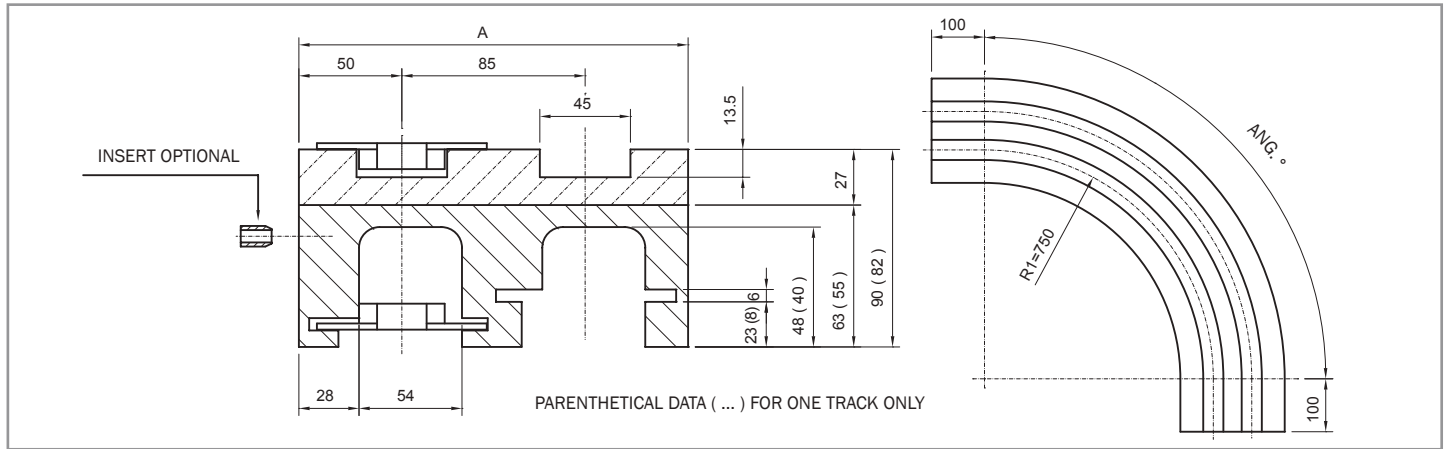

VERSION CM08

Nr. of Tracks	A	Curve angle 15°	Curve angle 30°	Curve angle 45°	Curve angle 60°	Curve angle 75°	Curve angle 90°
1	100	CM08 01 15	CM08 01 30	CM08 01 45	CM08 01 60	CM08 01 75	CM08 01 90
2	185	CM08 02 15	CM08 02 30	CM08 02 45	CM08 02 60	CM08 02 75	CM08 02 90
3	270	CM08 03 15	CM08 03 30	CM08 03 45	CM08 03 60	CM08 03 75	CM08 03 90
4	355	CM08 04 15	CM08 04 30	CM08 04 45	CM08 04 60	CM08 04 75	CM08 04 90
5	440	CM08 05 15	CM08 05 30	CM08 05 45	CM08 05 60	CM08 05 75	CM08 05 90
6	525	CM08 06 15	CM08 06 30	CM08 06 45	CM08 06 60	CM08 06 75	CM08 06 90
7	610	CM08 07 15	CM08 07 30	CM08 07 45	CM08 07 60	CM08 07 75	CM08 07 90
8	695	CM08 08 15	CM08 08 30	CM08 08 45	CM08 08 60	CM08 08 75	CM08 08 90

CHAINS REF.

- 879 M K325
- 880 M K325
- 880 M K330
- 8811 M K325
- 8811 M K330
- 581 M K325

More than 8 tracks on request.

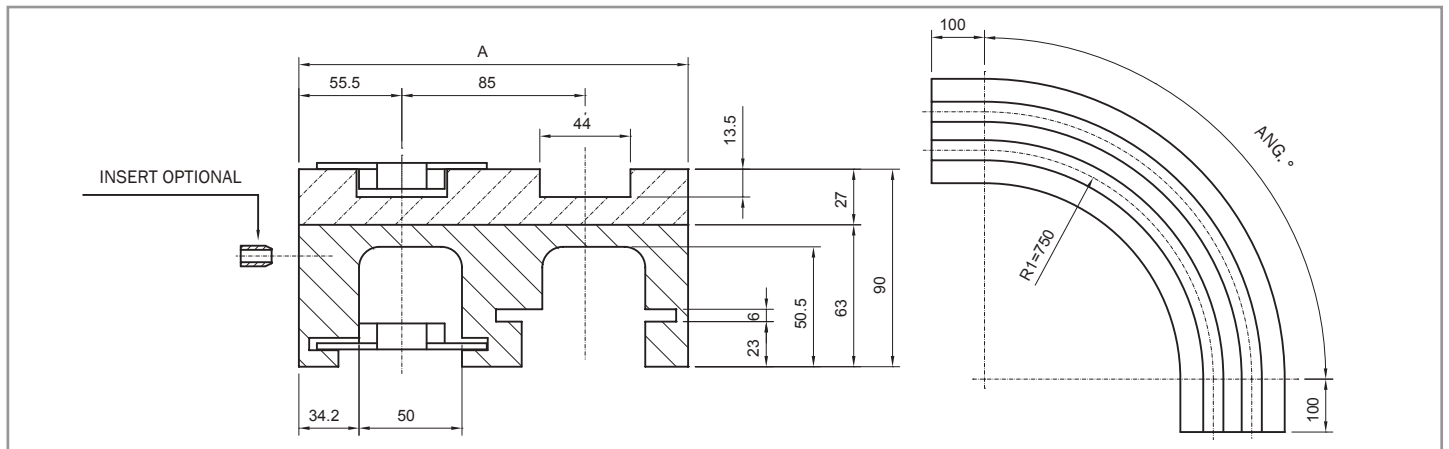

VERSION CM42

Nr. of Tracks	A	Curve angle 15°	Curve angle 30°	Curve angle 45°	Curve angle 60°	Curve angle 75°	Curve angle 90°
1	111	CM42 01 15	CM42 01 30	CM42 01 45	CM42 01 60	CM42 01 75	CM42 01 90
2	196	CM42 02 15	CM42 02 30	CM42 02 45	CM42 02 60	CM42 02 75	CM42 02 90
3	281	CM42 03 15	CM42 03 30	CM42 03 45	CM42 03 60	CM42 03 75	CM42 03 90
4	366	CM42 04 15	CM42 04 30	CM42 04 45	CM42 04 60	CM42 04 75	CM42 04 90
5	451	CM42 05 15	CM42 05 30	CM42 05 45	CM42 05 60	CM42 05 75	CM42 05 90
6	536	CM42 06 15	CM42 06 30	CM42 06 45	CM42 06 60	CM42 06 75	CM42 06 90
7	621	CM42 07 15	CM42 07 30	CM42 07 45	CM42 07 60	CM42 07 75	CM42 07 90

CHAINS REF.

- 879 M K325
- 880 M K325
- 880 M K330
- 8811 M K325
- 8811 M K330
- 581 M K325

More than 7 tracks on request.

magnetic corner tracks

VERSION CM09 / CM05C

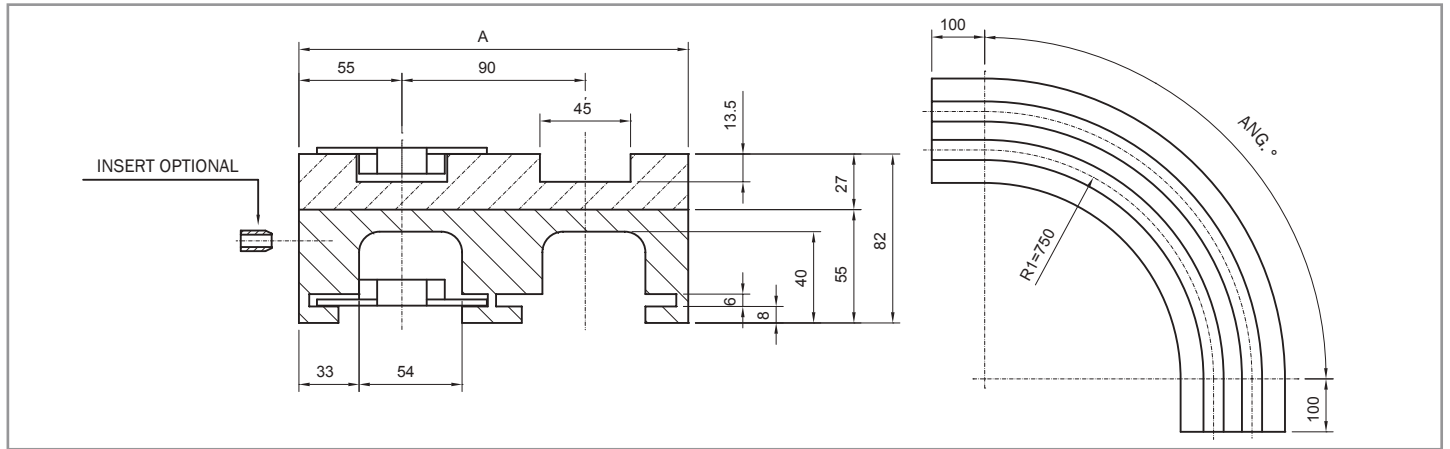

VERSION CM09

Nr. of Tracks	A	Curve angle 15°	Curve angle 30°	Curve angle 45°	Curve angle 60°	Curve angle 75°	Curve angle 90°
1	110	CM09 01 15	CM09 01 30	CM09 01 45	CM09 01 60	CM09 01 75	CM09 01 90
2	200	CM09 02 15	CM09 02 30	CM09 02 45	CM09 02 60	CM09 02 75	CM09 02 90
3	290	CM09 03 15	CM09 03 30	CM09 03 45	CM09 03 60	CM09 03 75	CM09 03 90
4	380	CM09 04 15	CM09 04 30	CM09 04 45	CM09 04 60	CM09 04 75	CM09 04 90
5	470	CM09 05 15	CM09 05 30	CM09 05 45	CM09 05 60	CM09 05 75	CM09 05 90
6	560	CM09 06 15	CM09 06 30	CM09 06 45	CM09 06 60	CM09 06 75	CM09 06 90
7	650	CM09 07 15	CM09 07 30	CM09 07 45	CM09 07 60	CM09 07 75	CM09 07 90
8	740	CM09 08 15	CM09 08 30	CM09 08 45	CM09 08 60	CM09 08 75	CM09 08 90

CHAINS REF.

- 879 M K325
- 880 M K325
- 880 M K330
- 8811 M K325
- 8811 M K330
- 581 M K325

More than 8 tracks on request.

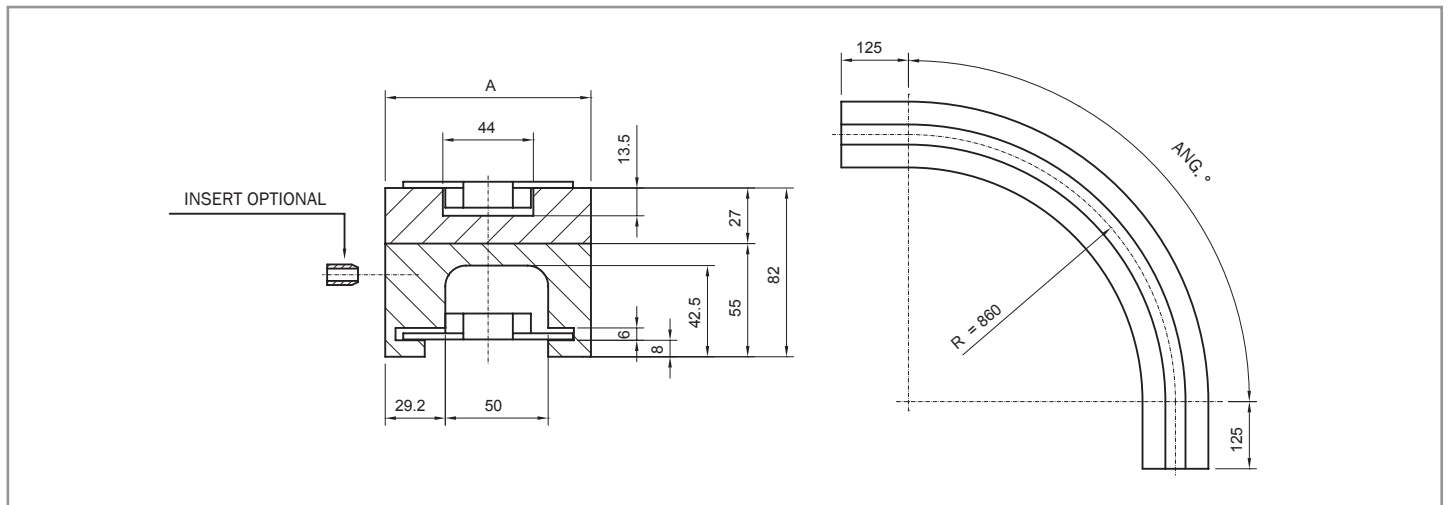

VERSION CM05C

Nr. of Tracks	A	Curve angle 15°	Curve angle 30°	Curve angle 45°	Curve angle 60°	Curve angle 75°	Curve angle 90°
1	100	CM05C 01 15	CM05C 01 30	CM05C 01 45	CM05C 01 60	CM05C 01 75	CM05C 01 90

CHAINS REF.

- 879 M K325
- 880 M K325
- 880 M K330
- 8811 M K325
- 8811 M K330
- 581 M K325

More than 1 track on request.

magnetic corner tracks

VERSION CM05D / CM43

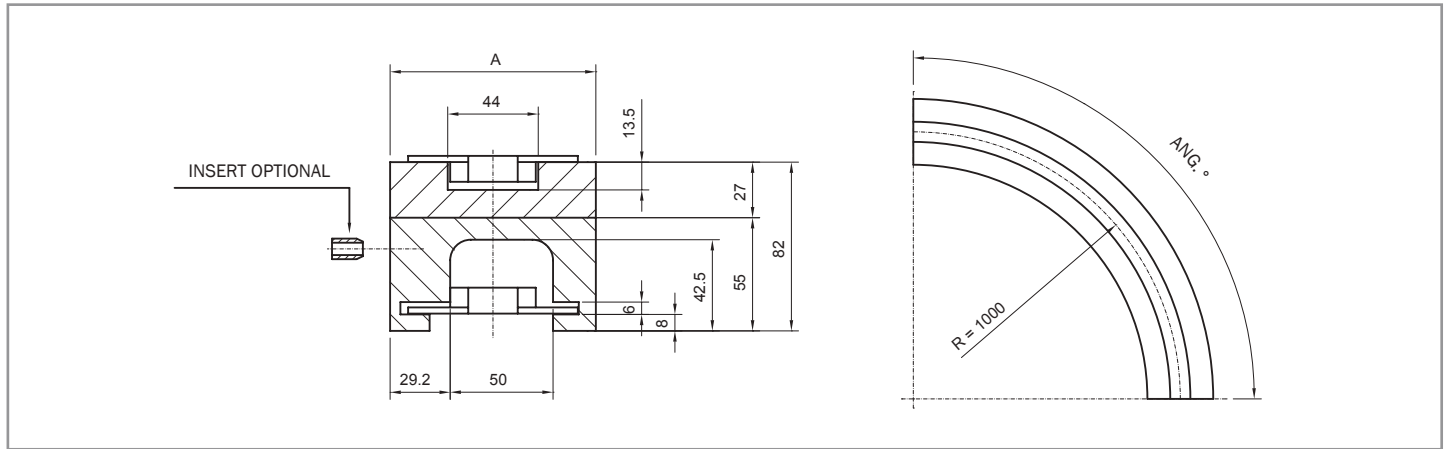

VERSION CM05D

Nr. of Tracks	A	Curve angle 15°	Curve angle 30°	Curve angle 45°	Curve angle 60°	Curve angle 75°	Curve angle 90°
1	100	CM05D 01 15	CM05D 01 30	CM05D 01 45	CM05D 01 60	CM05D 01 75	CM05D 01 90

More than 1 track on request.

CHAINS REF.

- 879 M K325
- 880 M K325
- 880 M K330
- 8811 M K325
- 8811 M K330
- 581 M K325

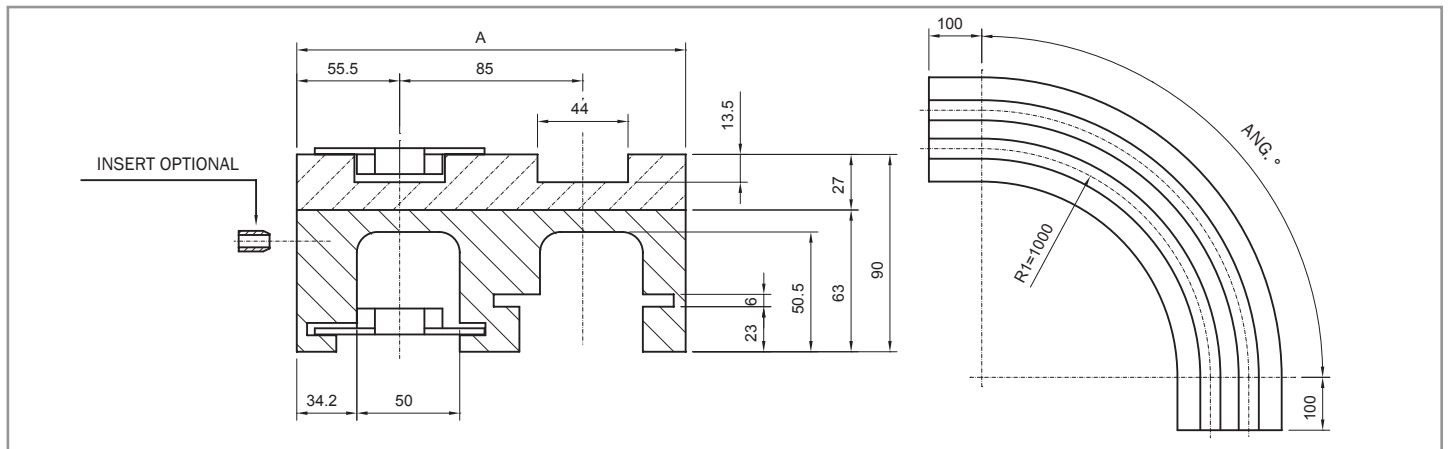

VERSION CM43

Nr. of Tracks	A	Curve angle 15°	Curve angle 30°	Curve angle 45°	Curve angle 60°	Curve angle 75°	Curve angle 90°
1	111	CM43 01 15	CM43 01 30	CM43 01 45	CM43 01 60	CM43 01 75	CM43 01 90
2	196	CM43 02 15	CM43 02 30	CM43 02 45	CM43 02 60	CM43 02 75	CM43 02 90
3	281	CM43 03 15	CM43 03 30	CM43 03 45	CM43 03 60	CM43 03 75	CM43 03 90
4	366	CM43 04 15	CM43 04 30	CM43 04 45	CM43 04 60	CM43 04 75	CM43 04 90
5	451	CM43 05 15	CM43 05 30	CM43 05 45	CM43 05 60	CM43 05 75	CM43 05 90
6	536	CM43 06 15	CM43 06 30	CM43 06 45	CM43 06 60	CM43 06 75	CM43 06 90
7	621	CM43 07 15	CM43 07 30	CM43 07 45	CM43 07 60	CM43 07 75	CM43 07 90

CHAINS REF.

- 879 M K325
- 880 M K325
- 880 M K330
- 8811 M K325
- 8811 M K330
- 581 M K325

More than 7 tracks on request.

magnetic corner tracks

VERSION CMF06 / CM21A

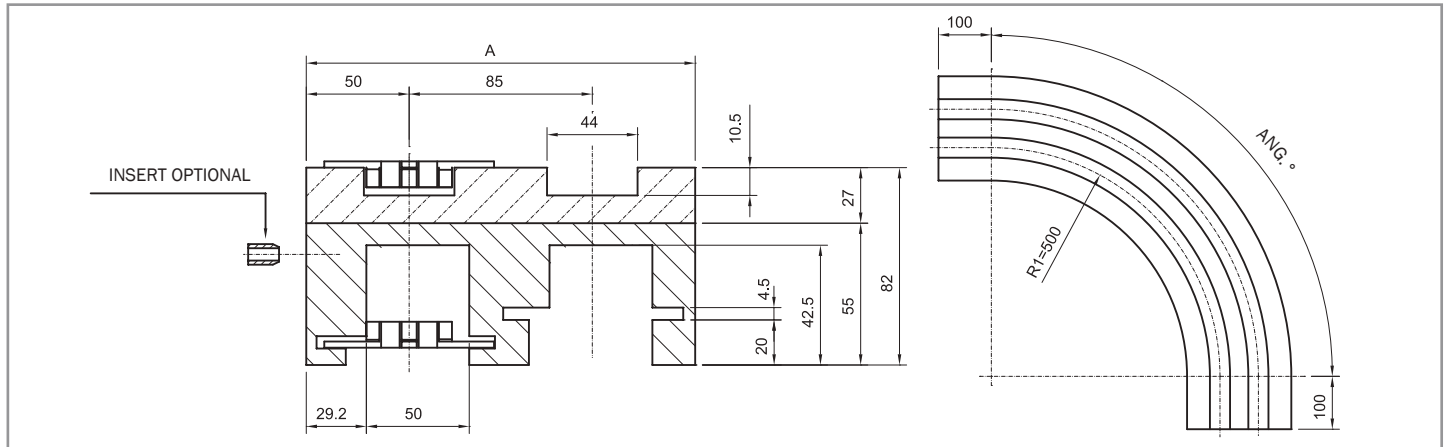

VERSION CMF06

CHAINS REF.

Nr. of Tracks	A	VERSION CMF06								CHAINS REF.				
		Curve angle 15°	Curve angle 30°	Curve angle 45°	Curve angle 60°	Curve angle 75°	Curve angle 90°	Curve angle 15°	Curve angle 30°		Curve angle 45°	Curve angle 60°	Curve angle 75°	Curve angle 90°
1	100	CMF06 01 15	CMF06 01 30	CMF06 01 45	CMF06 01 60	CMF06 01 75	CMF06 01 90	661 M K325						
2	185	CMF06 02 15	CMF06 02 30	CMF06 02 45	CMF06 02 60	CMF06 02 75	CMF06 02 90	661 M K330						
3	270	CMF06 03 15	CMF06 03 30	CMF06 03 45	CMF06 03 60	CMF06 03 75	CMF06 03 90							
4	355	CMF06 04 15	CMF06 04 30	CMF06 04 45	CMF06 04 60	CMF06 04 75	CMF06 04 90							
5	440	CMF06 05 15	CMF06 05 30	CMF06 05 45	CMF06 05 60	CMF06 05 75	CMF06 05 90							
6	525	CMF06 06 15	CMF06 06 30	CMF06 06 45	CMF06 06 60	CMF06 06 75	CMF06 06 90							
7	610	CMF06 07 15	CMF06 07 30	CMF06 07 45	CMF06 07 60	CMF06 07 75	CMF06 07 90							

More than 7 tracks on request.

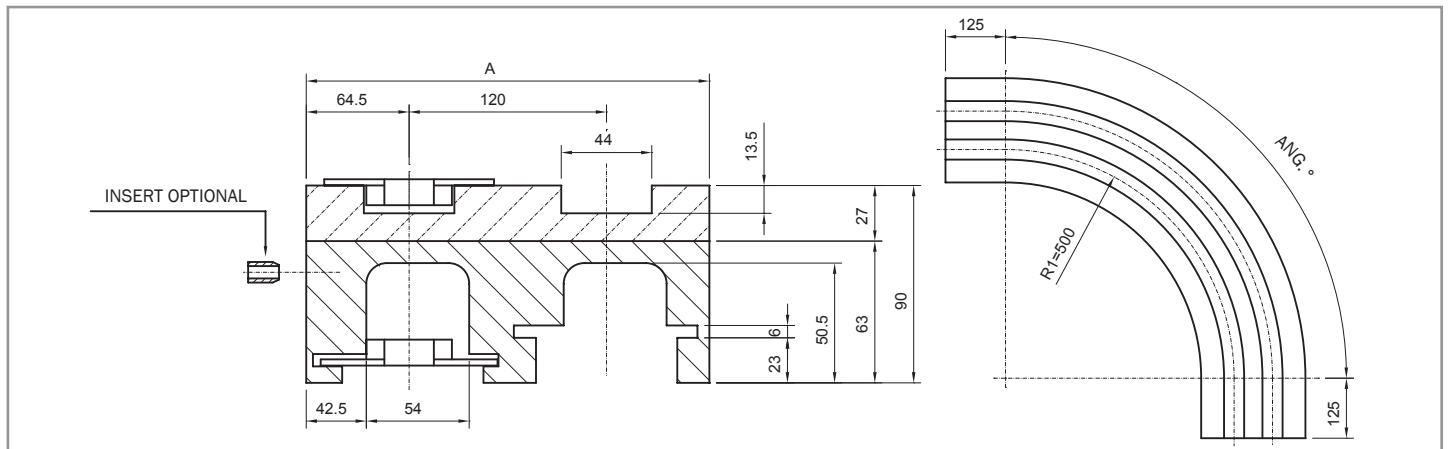

VERSION CM21A

CHAINS REF.

Nr. of Tracks	A	VERSION CM21A								CHAINS REF.				
		Curve angle 15°	Curve angle 30°	Curve angle 45°	Curve angle 60°	Curve angle 75°	Curve angle 90°	Curve angle 15°	Curve angle 30°		Curve angle 45°	Curve angle 60°	Curve angle 75°	Curve angle 90°
1	129	CM21A 01 15	CM21A 01 30	CM21A 01 45	CM21A 01 60	CM21A 01 75	CM21A 01 90	879 M K450						
2	249	CM21A 02 15	CM21A 02 30	CM21A 02 45	CM21A 02 60	CM21A 02 75	CM21A 02 90	880 M K450						
3	369	CM21A 03 15	CM21A 03 30	CM21A 03 45	CM21A 03 60	CM21A 03 75	CM21A 03 90	8811 M K450						
4	489	CM21A 04 15	CM21A 04 30	CM21A 04 45	CM21A 04 60	CM21A 04 75	CM21A 04 90							
5	609	CM21A 05 15	CM21A 05 30	CM21A 05 45	CM21A 05 60	CM21A 05 75	CM21A 05 90							

More than 5 tracks on request.

magnetic corner tracks

VERSION CM22A / CM27

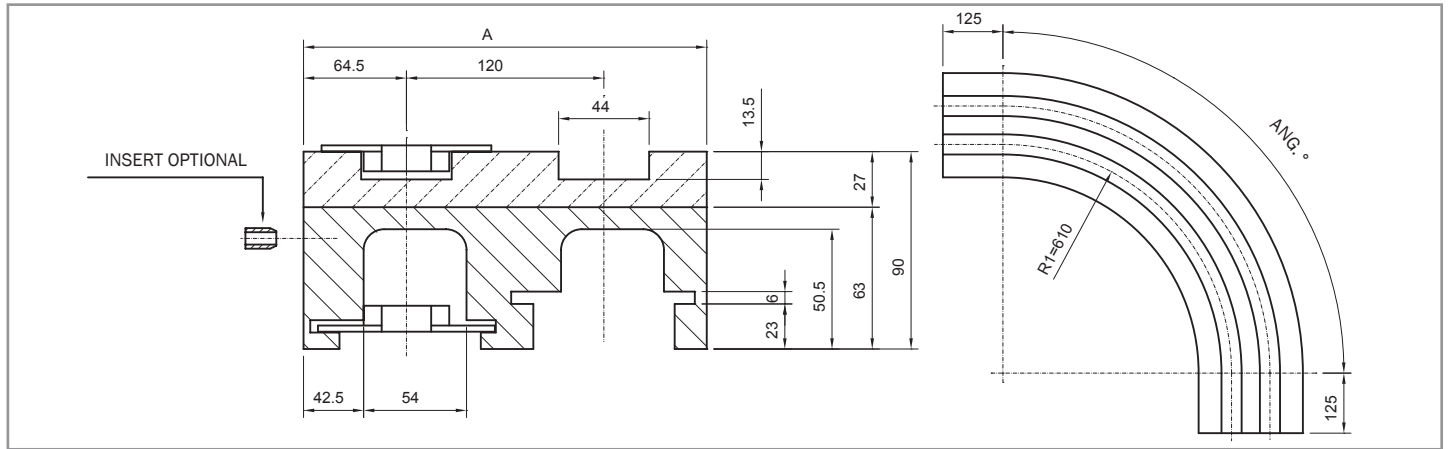

VERSION CM22A

Nr. of Tracks	A	Curve angle 15°	Curve angle 30°	Curve angle 45°	Curve angle 60°	Curve angle 75°	Curve angle 90°
1	129	CM22A 01 15	CM22A 01 30	CM22A 01 45	CM22A 01 60	CM22A 01 75	CM22A 01 90
2	249	CM22A 02 15	CM22A 02 30	CM22A 02 45	CM22A 02 60	CM22A 02 75	CM22A 02 90
3	369	CM22A 03 15	CM22A 03 30	CM22A 03 45	CM22A 03 60	CM22A 03 75	CM22A 03 90
4	489	CM22A 04 15	CM22A 04 30	CM22A 04 45	CM22A 04 60	CM22A 04 75	CM22A 04 90
5	609	CM22A 05 15	CM22A 05 30	CM22A 05 45	CM22A 05 60	CM22A 05 75	CM22A 05 90

CHAINS REF.

879 M K450
880 M K450
8811 M K450

More than 5 tracks on request.

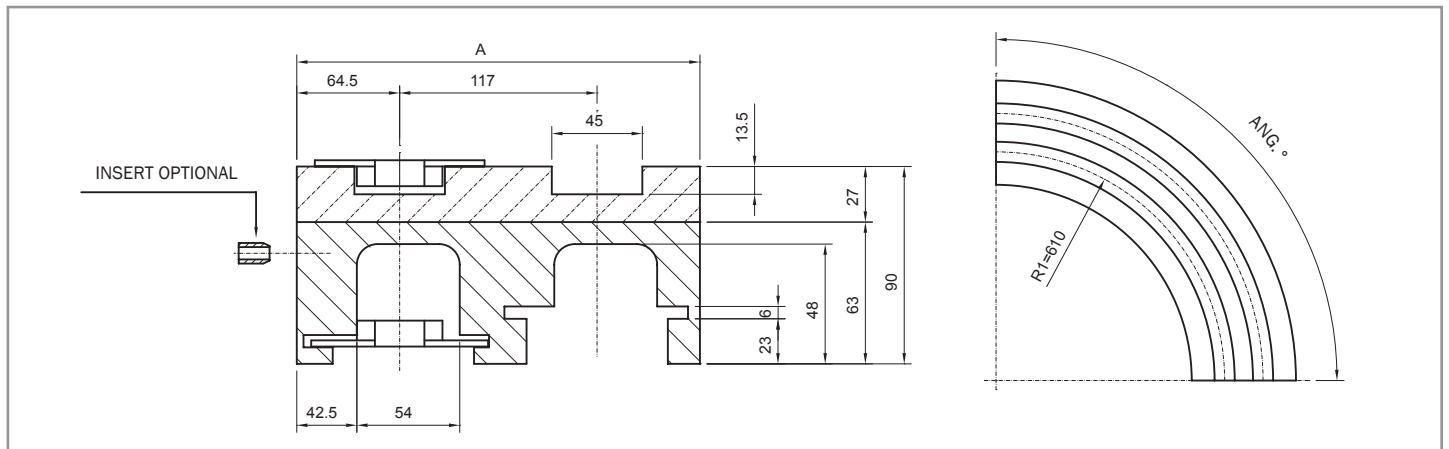

VERSION CM27

Nr. of Tracks	A	Curve angle 15°	Curve angle 30°	Curve angle 45°	Curve angle 60°	Curve angle 75°	Curve angle 90°
1	129	CM27 01 15	CM27 01 30	CM27 01 45	CM27 01 60	CM27 01 75	CM27 01 90
2	246	CM27 02 15	CM27 02 30	CM27 02 45	CM27 02 60	CM27 02 75	CM27 02 90
3	363	CM27 03 15	CM27 03 30	CM27 03 45	CM27 03 60	CM27 03 75	CM27 03 90
4	480	CM27 04 15	CM27 04 30	CM27 04 45	CM27 04 60	CM27 04 75	CM27 04 90
5	597	CM27 05 15	CM27 05 30	CM27 05 45	CM27 05 60	CM27 05 75	CM27 05 90
6	714	CM27 06 15	CM27 06 30	CM27 06 45	CM27 06 60	CM27 06 75	CM27 06 90
7	831	CM27 07 15	CM27 07 30	CM27 07 45	CM27 07 60	CM27 07 75	CM27 07 90
8	948	CM27 08 15	CM27 08 30	CM27 08 45	CM27 08 60	CM27 08 75	CM27 08 90

CHAINS REF.

879 M K450
880 M K450
8811 M K450

More than 8 tracks on request.

magnetic corner tracks

VERSION CM60 / CM61

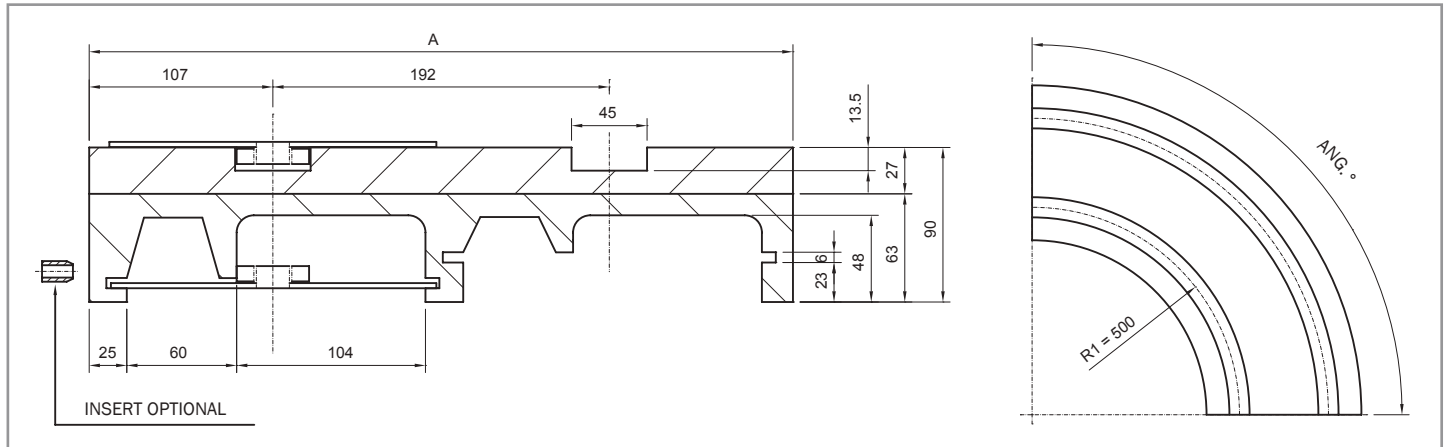

VERSION CM60

Nr. of Tracks	A	Curve angle 15°	Curve angle 30°	Curve angle 45°	Curve angle 60°	Curve angle 75°	Curve angle 90°
1	214	CM60 01 15	CM60 01 30	CM60 01 45	CM60 01 60	CM60 01 75	CM60 01 90
2	406	CM60 02 15	CM60 02 30	CM60 02 45	CM60 02 60	CM60 02 75	CM60 02 90
3	602	CM60 03 15	CM60 03 30	CM60 03 45	CM60 03 60	CM60 03 75	CM60 03 90

CHAINS REF.

880 M K750
8811 M K750

More than 3 tracks on request.

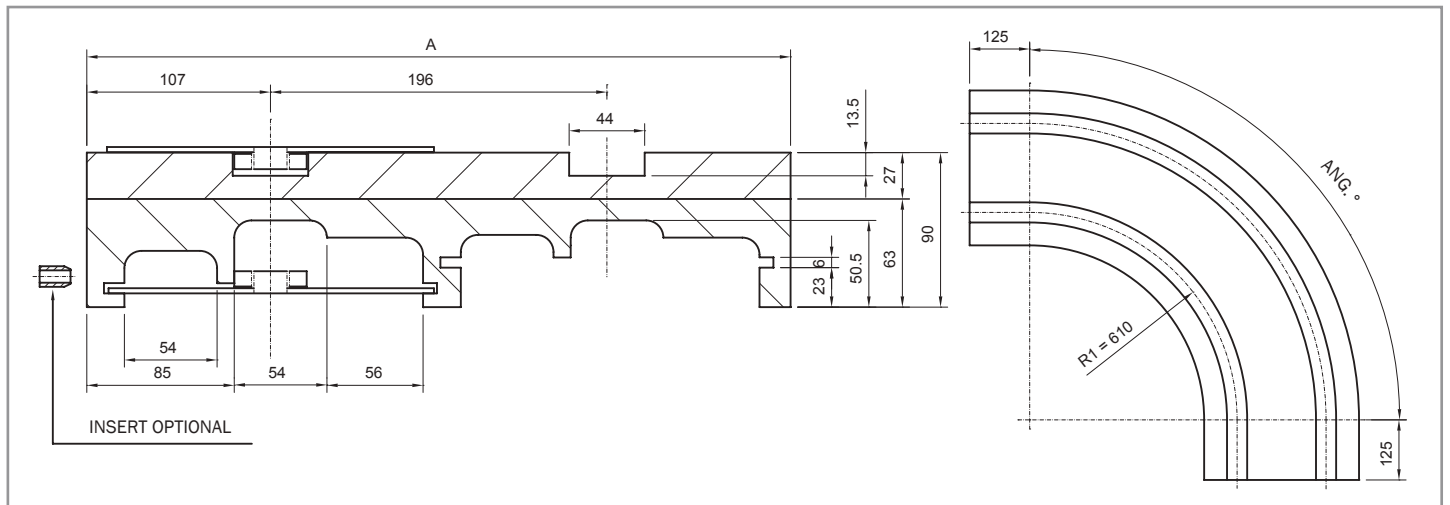

VERSION CM61

Nr. of Tracks	A	Curve angle 15°	Curve angle 30°	Curve angle 45°	Curve angle 60°	Curve angle 75°	Curve angle 90°
1	214	CM61 01 15	CM61 01 30	CM61 01 45	CM61 01 60	CM61 01 75	CM61 01 90
2	410	CM61 02 15	CM61 02 30	CM61 02 45	CM61 02 60	CM61 02 75	CM61 02 90
3	606	CM61 03 15	CM61 03 30	CM61 03 45	CM61 03 60	CM61 03 75	CM61 03 90
4	802	CM61 04 15	CM61 04 30	CM61 04 45	CM61 04 60	CM61 04 75	CM61 04 90

CHAINS REF.

880 M K750
8811 M K750

More than 4 tracks on request.

magnetic corner tracks

VERSION CM62 / CM66

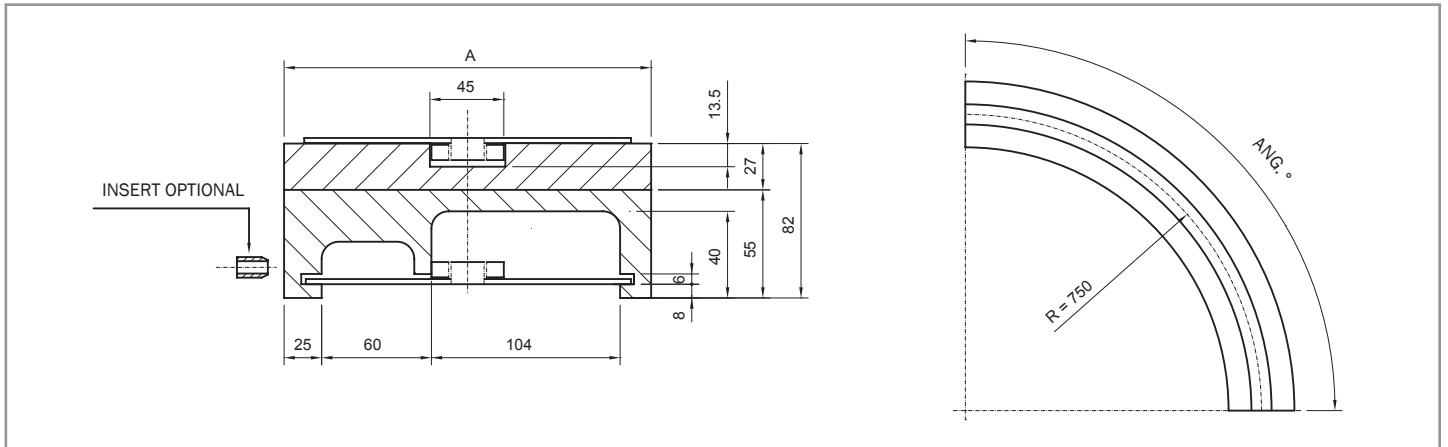

VERSION CM62

Nr. of Tracks	A	Curve angle 15°	Curve angle 30°	Curve angle 45°	Curve angle 60°	Curve angle 75°	Curve angle 90°
1	214	CM62 01 15	CM62 01 30	CM62 01 45	CM62 01 60	CM62 01 75	CM62 01 90

CHAINS REF.

880 M K750
8811 M K750

More than 1 track on request.

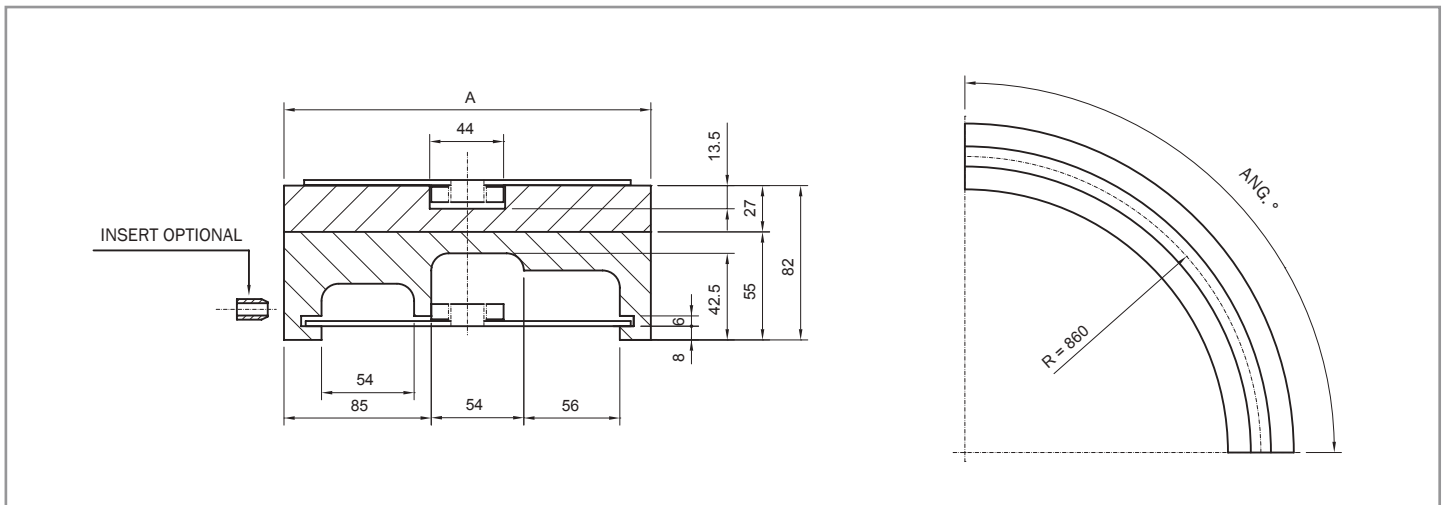

VERSION CM66

Nr. of Tracks	A	Curve angle 15°	Curve angle 30°	Curve angle 45°	Curve angle 60°	Curve angle 75°	Curve angle 90°
1	214	CM66 01 15	CM66 01 30	CM66 01 45	CM66 01 60	CM66 01 75	CM66 01 90

CHAINS REF.

880 M K750
8811 M K750

More than 1 track on request.

magnetic corner tracks

VERSION CM65 / CM81

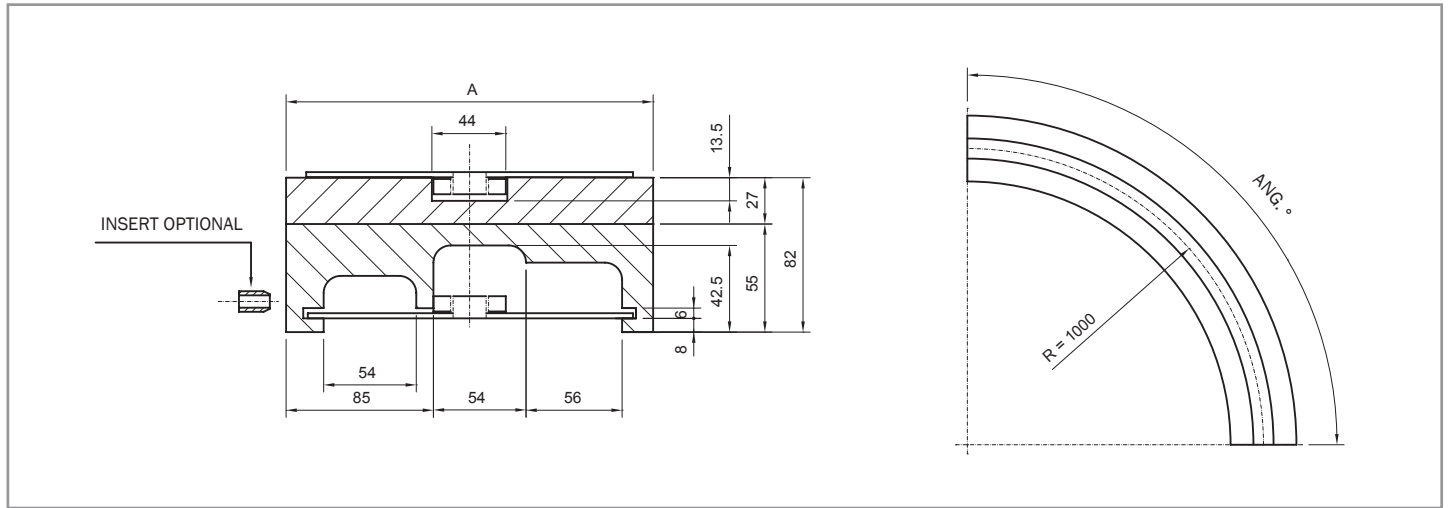

VERSION CM65

Nr. of Tracks	A	Curve angle 15°	Curve angle 30°	Curve angle 45°	Curve angle 60°	Curve angle 75°	Curve angle 90°
1	214	CM65 01 15	CM65 01 30	CM65 01 45	CM65 01 60	CM65 01 75	CM65 01 90

CHAINS REF.

880 M K750
8811 M K750

More than 1 track on request.

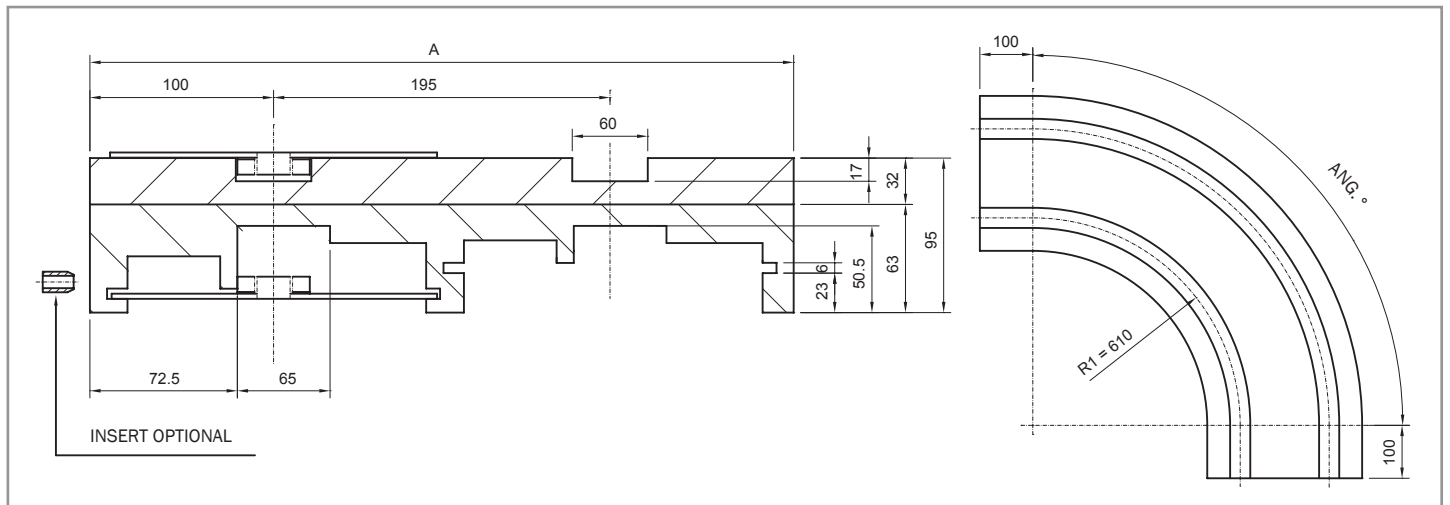

VERSION CM81

Nr. of Tracks	A	Curve angle 15°	Curve angle 30°	Curve angle 45°	Curve angle 60°	Curve angle 75°	Curve angle 90°
1	200	CM81 01 15	CM81 01 30	CM81 01 45	CM81 01 60	CM81 01 75	CM81 01 90
2	395	CM81 02 15	CM81 02 30	CM81 02 45	CM81 02 60	CM81 02 75	CM81 02 90
3	590	CM81 03 15	CM81 03 30	CM81 03 45	CM81 03 60	CM81 03 75	CM81 03 90
4	785	CM81 04 15	CM81 04 30	CM81 04 45	CM81 04 60	CM81 04 75	CM81 04 90

CHAINS REF.

8817 M K750
8817 M G K750
882 M K750

More than 4 tracks on request.

magnetic corner tracks

VERSION CM85 / CM86

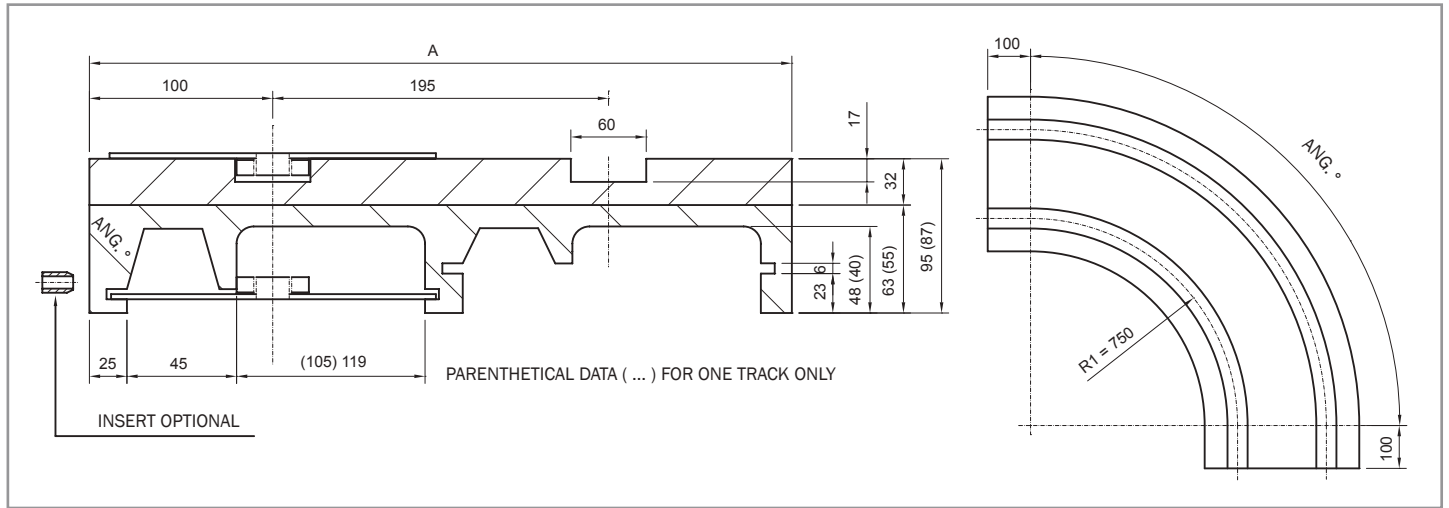

VERSION CM85

Nr. of Tracks	A	Curve angle 15°	Curve angle 30°	Curve angle 45°	Curve angle 60°	Curve angle 75°	Curve angle 90°
1	200	CM85 01 15	CM85 01 30	CM85 01 45	CM85 01 60	CM85 01 75	CM85 01 90
2	395	CM85 02 15	CM85 02 30	CM85 02 45	CM85 02 60	CM85 02 75	CM85 02 90
3	590	CM85 03 15	CM85 03 30	CM85 03 45	CM85 03 60	CM85 03 75	CM85 03 90

CHAINS REF.

8817 M K750
8817 M G K750
882 M K750

More than 3 tracks on request.

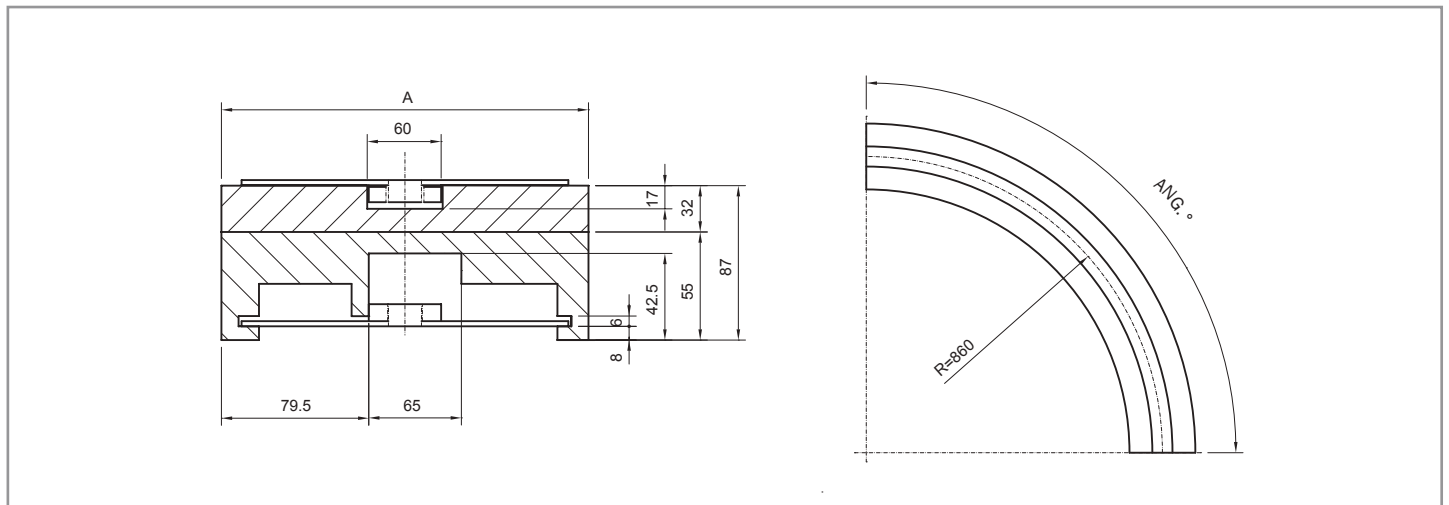

VERSION CM86

Nr. of Tracks	A	Curve angle 15°	Curve angle 30°	Curve angle 45°	Curve angle 60°	Curve angle 75°	Curve angle 90°
1	214	CM86 01 15	CM86 01 30	CM86 01 45	CM86 01 60	CM86 01 75	CM86 01 90

CHAINS REF.

8817 M K750
8817 M G K750
882 M K750

More than 1 track on request.

magnetic corner tracks

VERSION CM80 / CM91

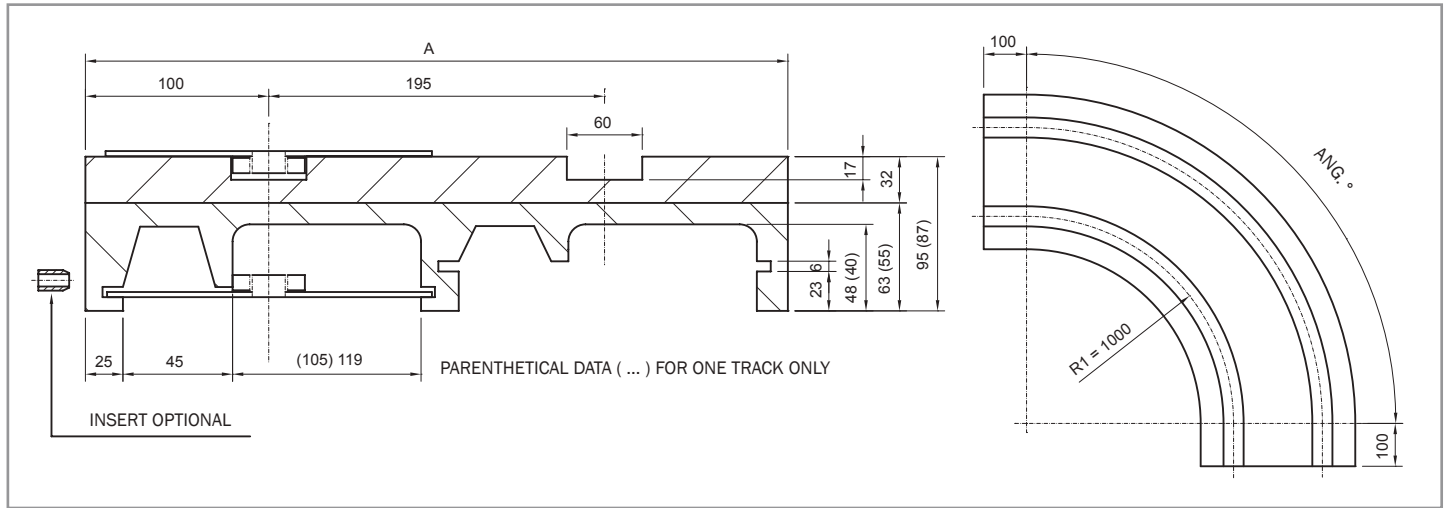

VERSION CM80								CHAINS REF.
Nr. of Tracks	A	Curve angle 15°	Curve angle 30°	Curve angle 45°	Curve angle 60°	Curve angle 75°	Curve angle 90°	8817 M K750
1	200	CM80 01 15	CM80 01 30	CM80 01 45	CM80 01 60	CM80 01 75	CM80 01 90	8817 M G K750
2	395	CM80 02 15	CM80 02 30	CM80 02 45	CM80 02 60	CM80 02 75	CM80 02 90	882 M K750
3	590	CM80 03 15	CM80 03 30	CM80 03 45	CM80 03 60	CM80 03 75	CM80 03 90	More than 3 tracks on request.

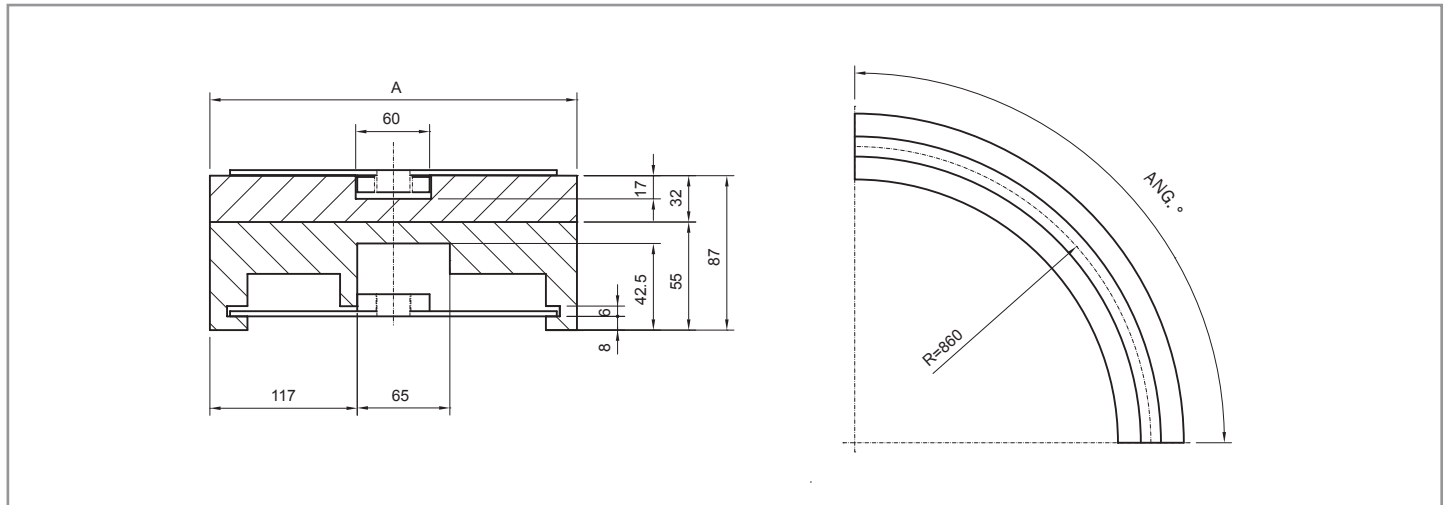

VERSION CM91								CHAINS REF.
Nr. of Tracks	A	Curve angle 15°	Curve angle 30°	Curve angle 45°	Curve angle 60°	Curve angle 75°	Curve angle 90°	882 M K1000
1	290	CM91 01 15	CM91 01 30	CM91 01 45	CM91 01 60	CM91 01 75	CM91 01 90	More than 1 track on request.

magnetic corner tracks

VERSION CM93 / CM94

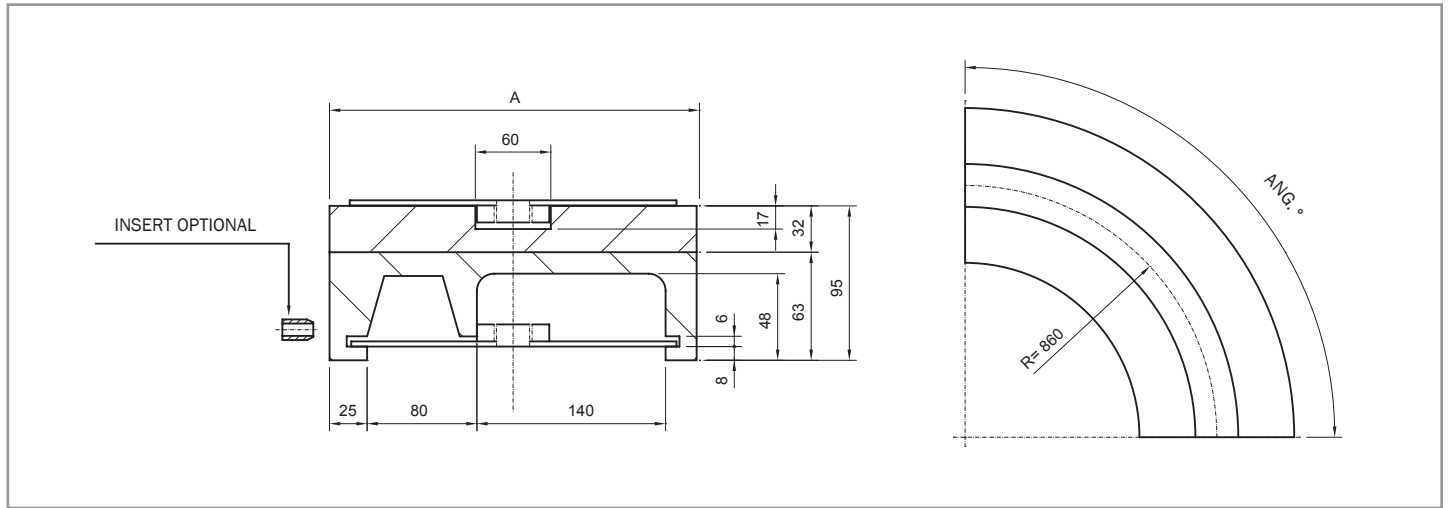

VERSION CM93

CHAINS REF.

Nr. of Tracks	A	Curve angle 15°	Curve angle 30°	Curve angle 45°	Curve angle 60°	Curve angle 75°	Curve angle 90°	882 M K1000
1	270	CM93 01 15	CM93 01 30	CM93 01 45	CM93 01 60	CM93 01 75	CM93 01 90	More than 1 track on request.

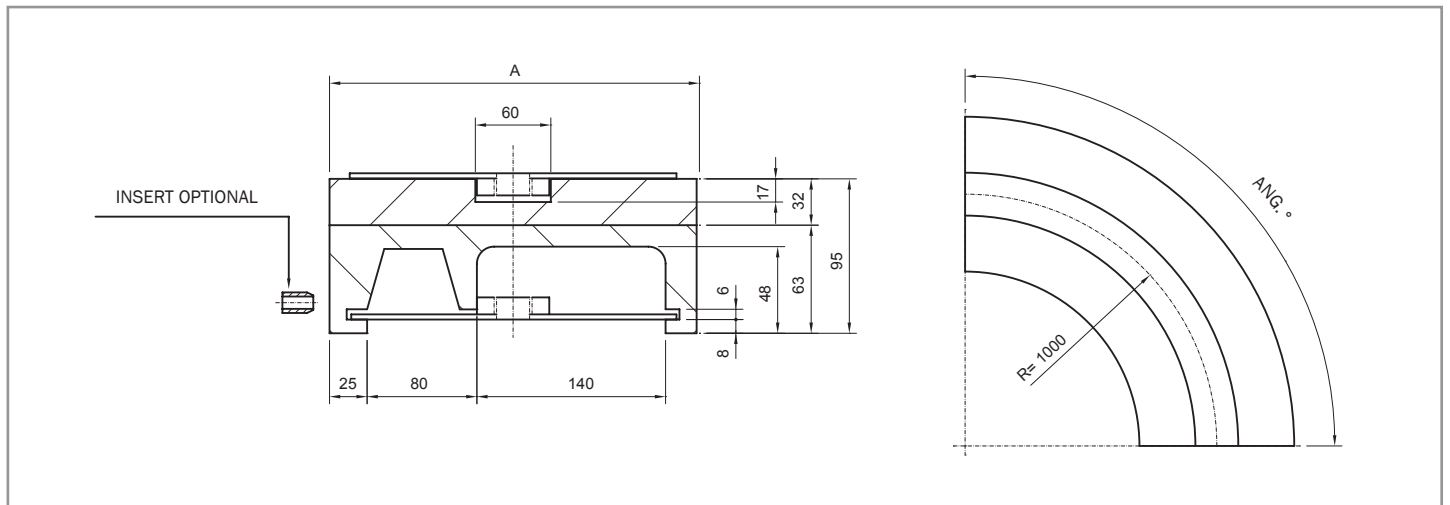

VERSION CM94

CHAINS REF.

Nr. of Tracks	A	Curve angle 15°	Curve angle 30°	Curve angle 45°	Curve angle 60°	Curve angle 75°	Curve angle 90°	882 M K1000
1	270	CM94 01 15	CM94 01 30	CM94 01 45	CM94 01 60	CM94 01 75	CM94 01 90	More than 1 track on request.

magnetic corner tracks

VERSION CM96 / CM97

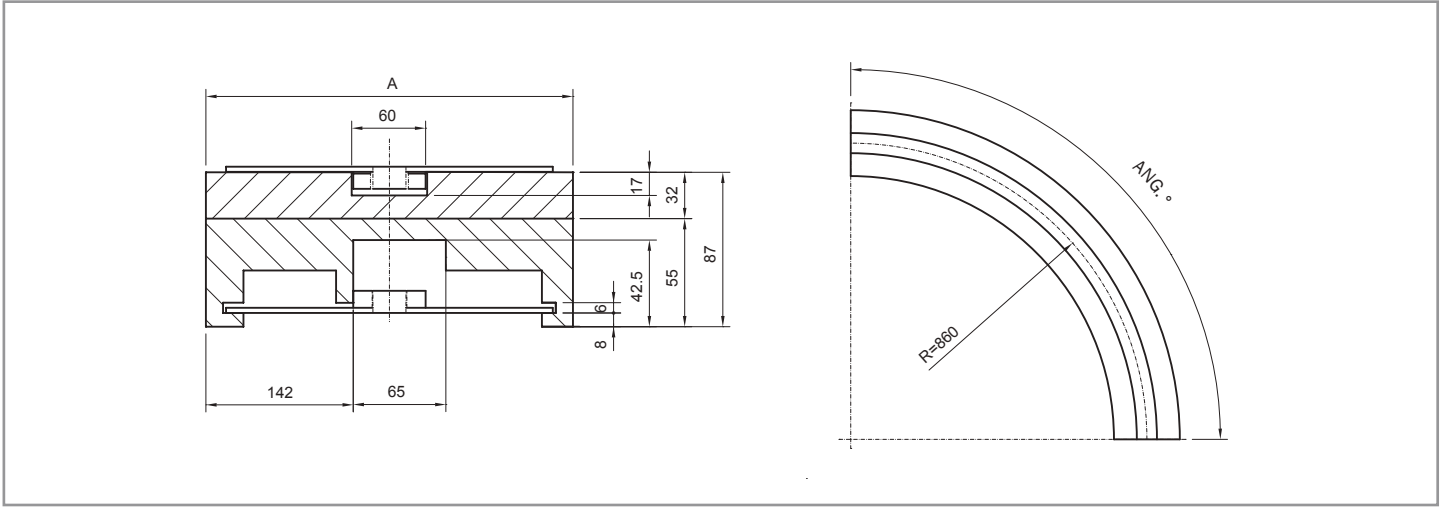

VERSION CM96

CHAINS REF.

Nr. of Tracks	A	Curve angle 15°	Curve angle 30°	Curve angle 45°	Curve angle 60°	Curve angle 75°	Curve angle 90°	882 M K1200
1	340	CM96 01 15	CM96 01 30	CM96 01 45	CM96 01 60	CM96 01 75	CM96 01 90	More than 1 track on request.

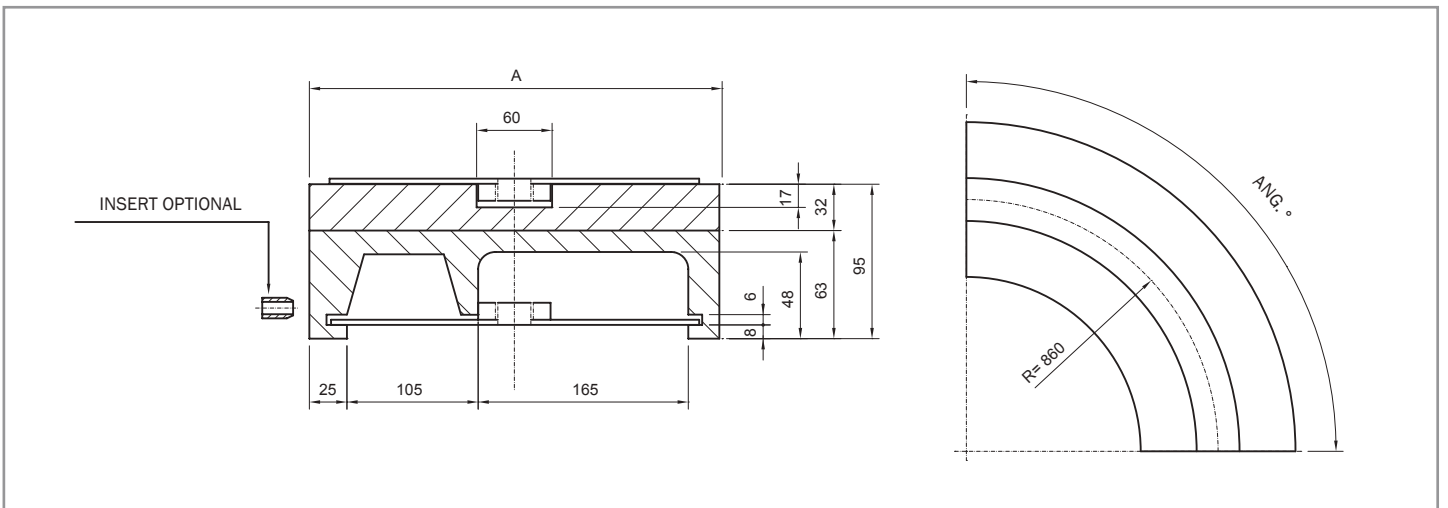

VERSION CM97

CHAINS REF.

Nr. of Tracks	A	Curve angle 15°	Curve angle 30°	Curve angle 45°	Curve angle 60°	Curve angle 75°	Curve angle 90°	882 M K1200
1	320	CM97 01 15	CM97 01 30	CM97 01 45	CM97 01 60	CM97 01 75	CM97 01 90	More than 1 track on request.

magnetic corner tracks

VERSION CM98 / CMP68C

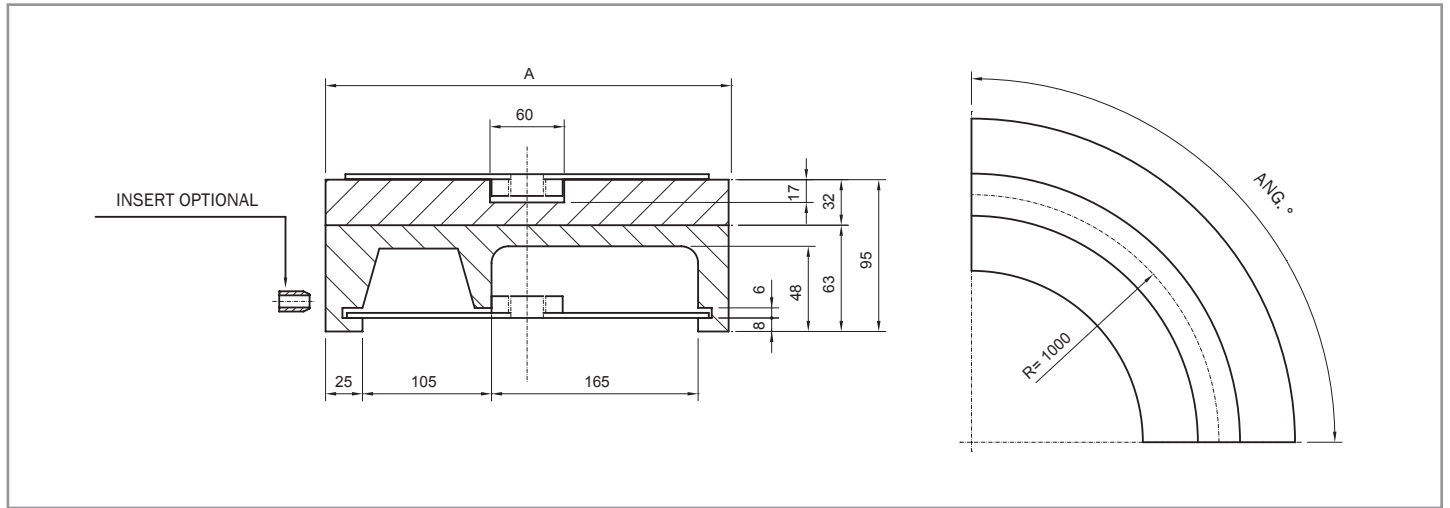

VERSION CM98

CHAINS REF.

Nr. of Tracks	A	Curve angle 15°	Curve angle 30°	Curve angle 45°	Curve angle 60°	Curve angle 75°	Curve angle 90°	882 M K1200
1	320	CM98 01 15	CM98 01 30	CM98 01 45	CM98 01 60	CM98 01 75	CM98 01 90	More than 1 track on request.

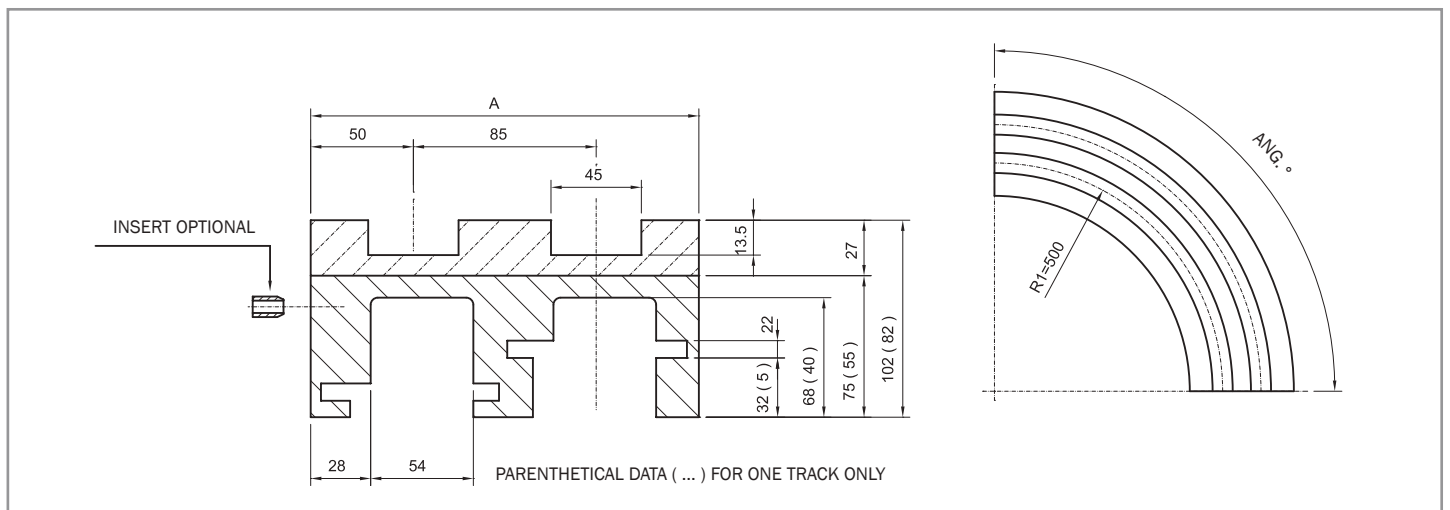

VERSION CMP68C

CHAINS REF.

Nr. of Tracks	A	Curve angle 15°	Curve angle 30°	Curve angle 45°	Curve angle 60°	Curve angle 75°	Curve angle 90°	LBP 879 M K325
1	100	CMP68C 01 15	CMP68C 01 30	CMP68C 01 45	CMP68C 01 60	CMP68C 01 75	CMP68C 01 90	More than 8 tracks on request.
2	185	CMP68C 02 15	CMP68C 02 30	CMP68C 02 45	CMP68C 02 60	CMP68C 02 75	CMP68C 02 90	
3	270	CMP68C 03 15	CMP68C 03 30	CMP68C 03 45	CMP68C 03 60	CMP68C 03 75	CMP68C 03 90	
4	355	CMP68C 04 15	CMP68C 04 30	CMP68C 04 45	CMP68C 04 60	CMP68C 04 75	CMP68C 04 90	
5	440	CMP68C 05 15	CMP68C 05 30	CMP68C 05 45	CMP68C 05 60	CMP68C 05 75	CMP68C 05 90	
6	525	CMP68C 06 15	CMP68C 06 30	CMP68C 06 45	CMP68C 06 60	CMP68C 06 75	CMP68C 06 90	
7	610	CMP68C 07 15	CMP68C 07 30	CMP68C 07 45	CMP68C 07 60	CMP68C 07 75	CMP68C 07 90	
8	695	CMP68C 08 15	CMP68C 08 30	CMP68C 08 45	CMP68C 08 60	CMP68C 08 75	CMP68C 08 90	

magnetic corner tracks

VERSION CMP02 / CMP861

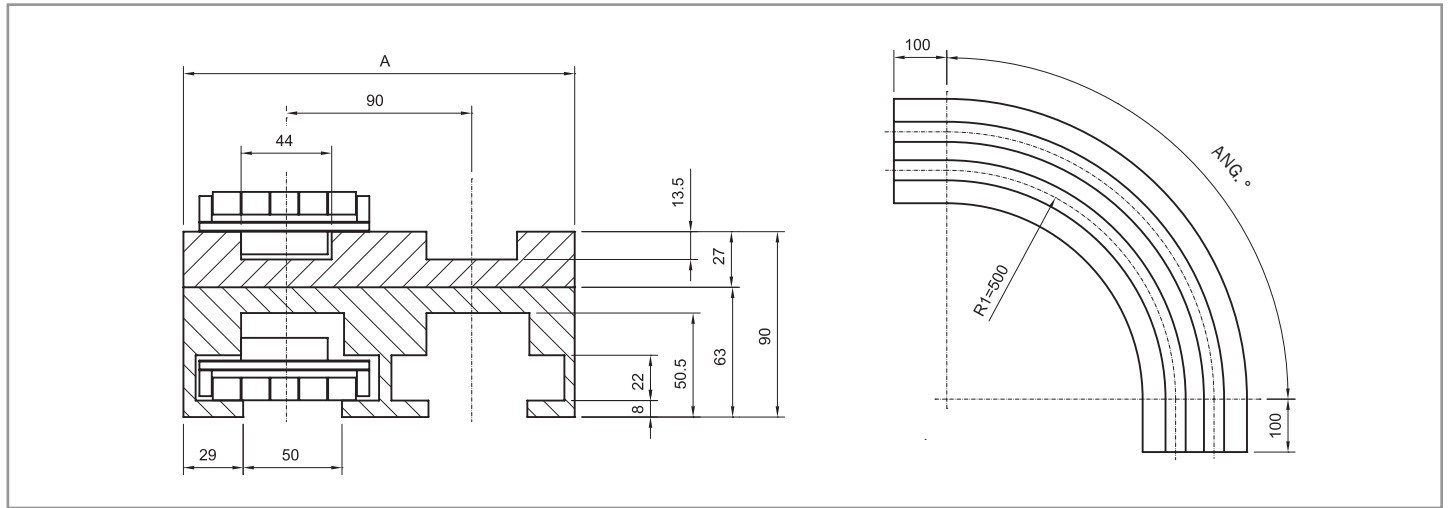

VERSION CMP02

CHAINS REF.

Nr. of Tracks	A	Curve angle 15°	Curve angle 30°	Curve angle 45°	Curve angle 60°	Curve angle 75°	Curve angle 90°	LBP 882 M K325
1	100	CMP02 01 15	CMP02 01 30	CMP02 01 45	CMP02 01 60	CMP02 01 75	CMP02 01 90	
2	190	CMP02 02 15	CMP02 02 30	CMP02 02 45	CMP02 02 60	CMP02 02 75	CMP02 02 90	
3	280	CMP02 03 15	CMP02 03 30	CMP02 03 45	CMP02 03 60	CMP02 03 75	CMP02 03 90	
4	370	CMP02 04 15	CMP02 04 30	CMP02 04 45	CMP02 04 60	CMP02 04 75	CMP02 04 90	
5	460	CMP02 05 15	CMP02 05 30	CMP02 05 45	CMP02 05 60	CMP02 05 75	CMP02 05 90	
6	550	CMP02 06 15	CMP02 06 30	CMP02 06 45	CMP02 06 60	CMP02 06 75	CMP02 06 90	More than 6 tracks on request.

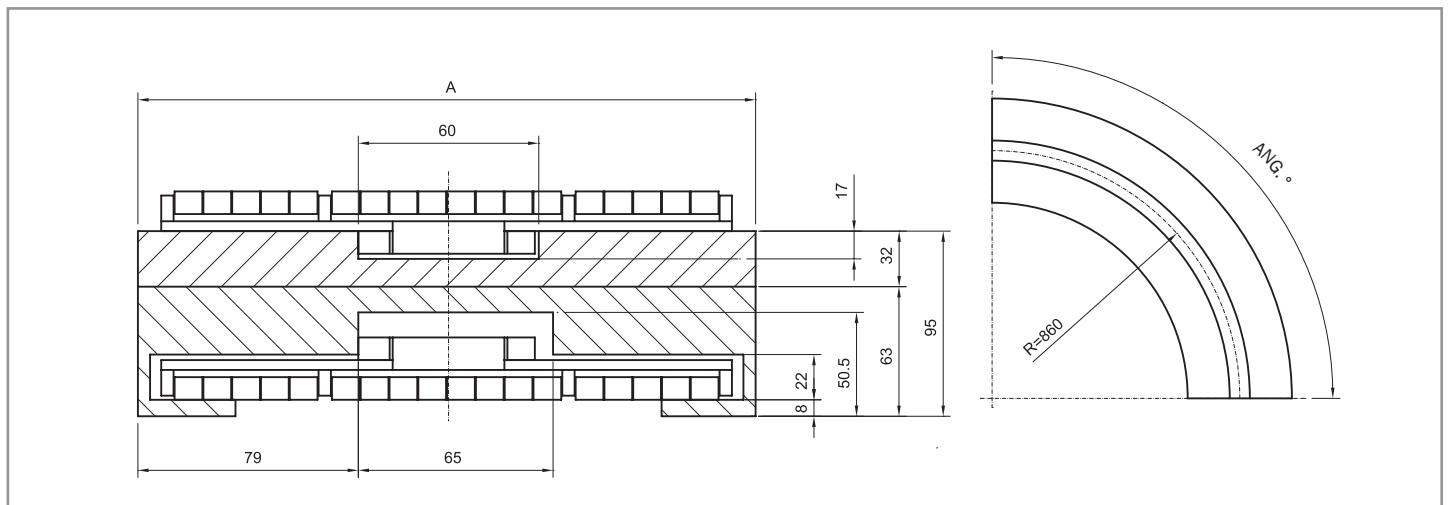

VERSION CMP861

CHAINS REF.

Nr. of Tracks	A	Curve angle 15°	Curve angle 30°	Curve angle 45°	Curve angle 60°	Curve angle 75°	Curve angle 90°	LBP 882 M K750
1	214	CMP861 01 15	CMP861 01 30	CMP861 01 45	CMP861 01 60	CMP861 01 75	CMP861 01 90	More than 1 track on request.

magnetic corner tracks

VERSION CMP86C / CMP93C

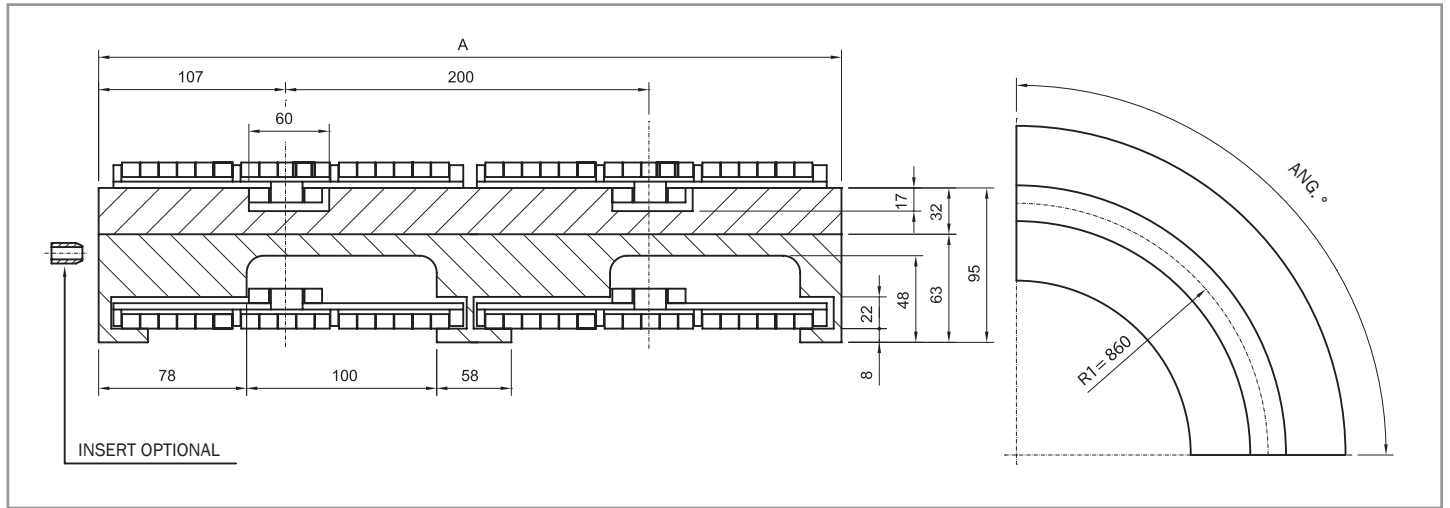

VERSION CMP86C

CHAINS REF.

Nr. of Tracks	A	Curve angle 15°	Curve angle 30°	Curve angle 45°	Curve angle 60°	Curve angle 75°	Curve angle 90°	LBP 882 M K750
1	214	CMP86C 01 15	CMP86C 01 30	CMP86C 01 45	CMP86C 01 60	CMP86C 01 75	CMP86C 01 90	More than 3 tracks on request.
2	414	CMP86C 02 15	CMP86C 02 30	CMP86C 02 45	CMP86C 02 60	CMP86C 02 75	CMP86C 02 90	
3	614	CMP86C 03 15	CMP86C 03 30	CMP86C 03 45	CMP86C 03 60	CMP86C 03 75	CMP86C 03 90	

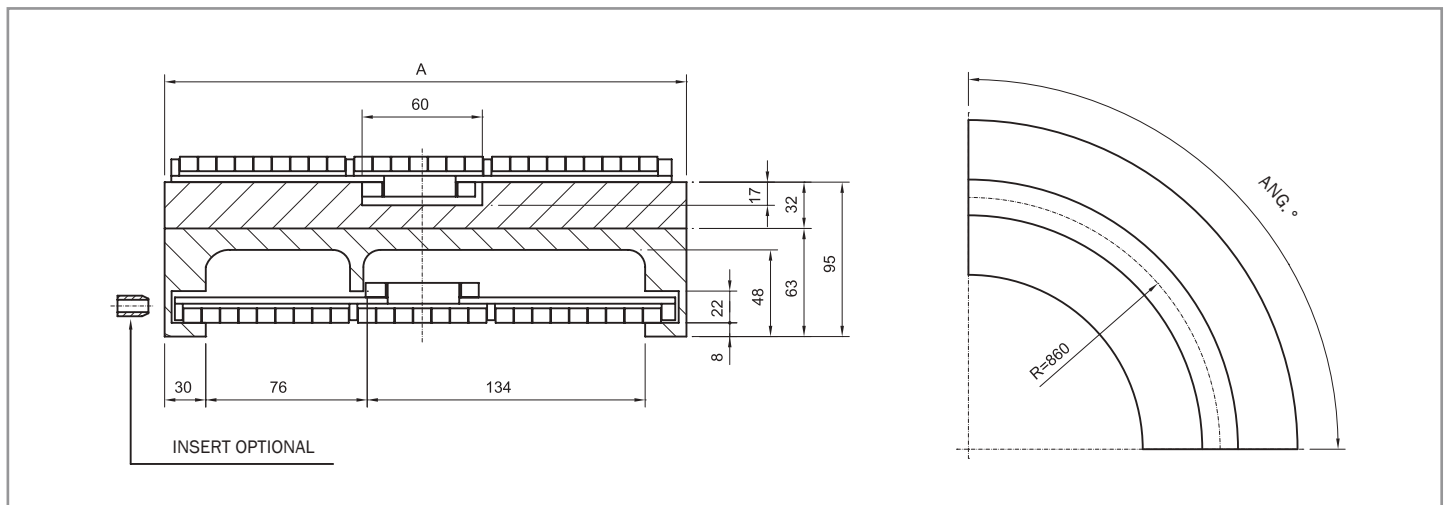

VERSION CMP93C

CHAINS REF.

Nr. of Tracks	A	Curve angle 15°	Curve angle 30°	Curve angle 45°	Curve angle 60°	Curve angle 75°	Curve angle 90°	LBP 882 M K1000
1	270	CMP93C 01 15	CMP93C 01 30	CMP93C 01 45	CMP93C 01 60	CMP93C 01 75	CMP93C 01 90	More than 1 track on request.

magnetic corner tracks

VERSION CMP91 / CMP94C

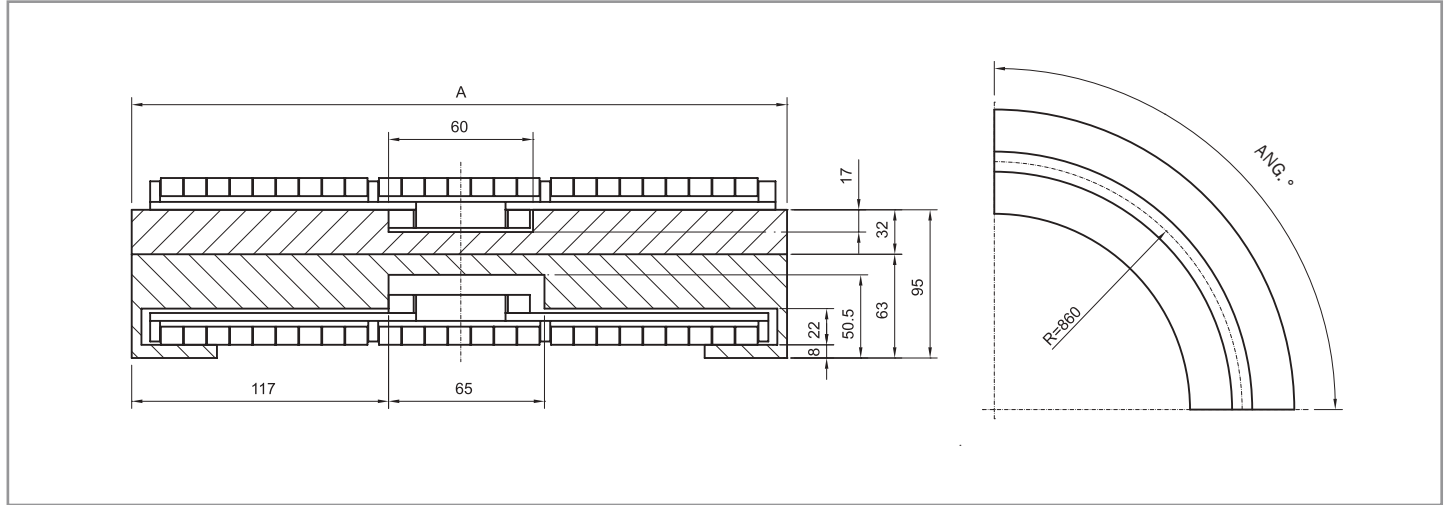

VERSION CMP91

CHAINS REF.

Nr. of Tracks	A	Curve angle 15°	Curve angle 30°	Curve angle 45°	Curve angle 60°	Curve angle 75°	Curve angle 90°	LBP 882 M K1000
1	290	CMP91 01 15	CMP91 01 30	CMP91 01 45	CMP91 01 60	CMP91 01 75	CMP91 01 90	More than 1 track on request.

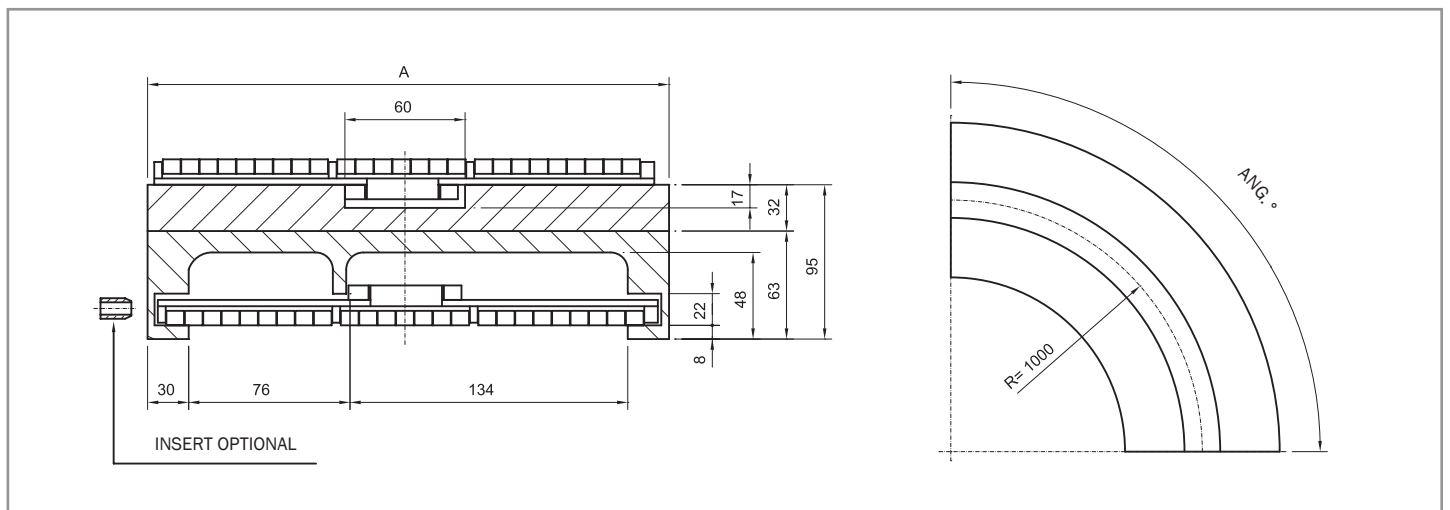

VERSION CMP94C

CHAINS REF.

Nr. of Tracks	A	Curve angle 15°	Curve angle 30°	Curve angle 45°	Curve angle 60°	Curve angle 75°	Curve angle 90°	LBP 882 M K1000
1	270	CMP94C 01 15	CMP94C 01 30	CMP94C 01 45	CMP94C 01 60	CMP94C 01 75	CMP94C 01 90	More than 1 track on request.

magnetic corner tracks

VERSION CMP97C / CMP96

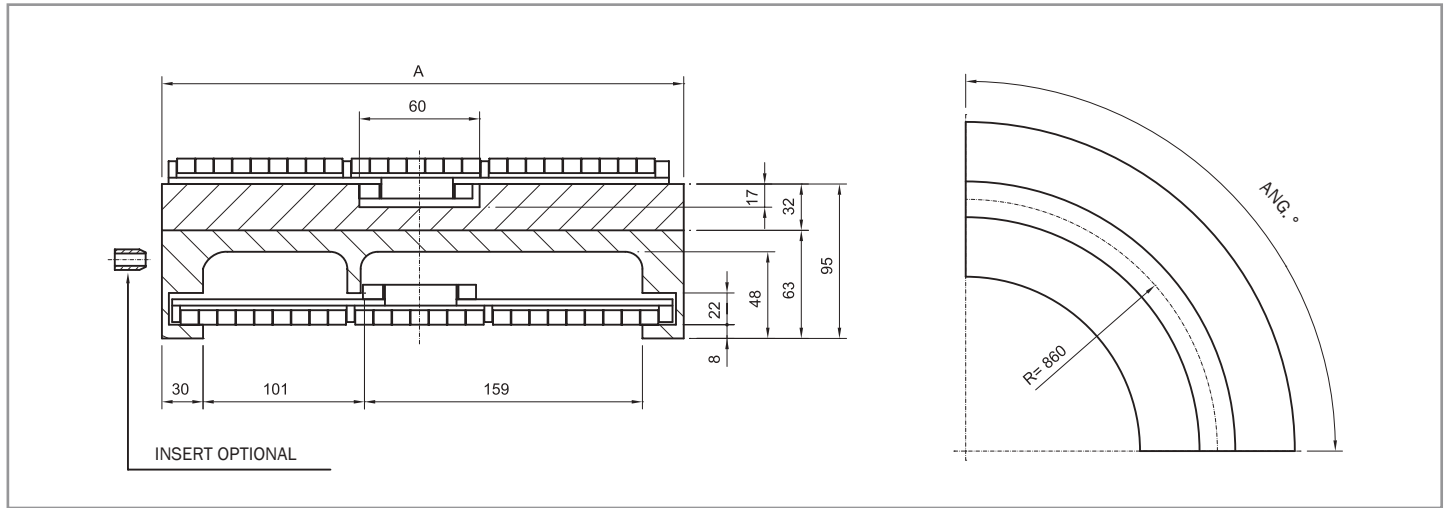

VERSION CMP97C

CHAINS REF.

Nr. of Tracks	A	Curve angle 15°	Curve angle 30°	Curve angle 45°	Curve angle 60°	Curve angle 75°	Curve angle 90°	LBP 882 M K1200
1	320	CMP97C 01 15	CMP97C 01 30	CMP97C 01 45	CMP97C 01 60	CMP97C 01 75	CMP97C 01 90	More than 1 track on request.

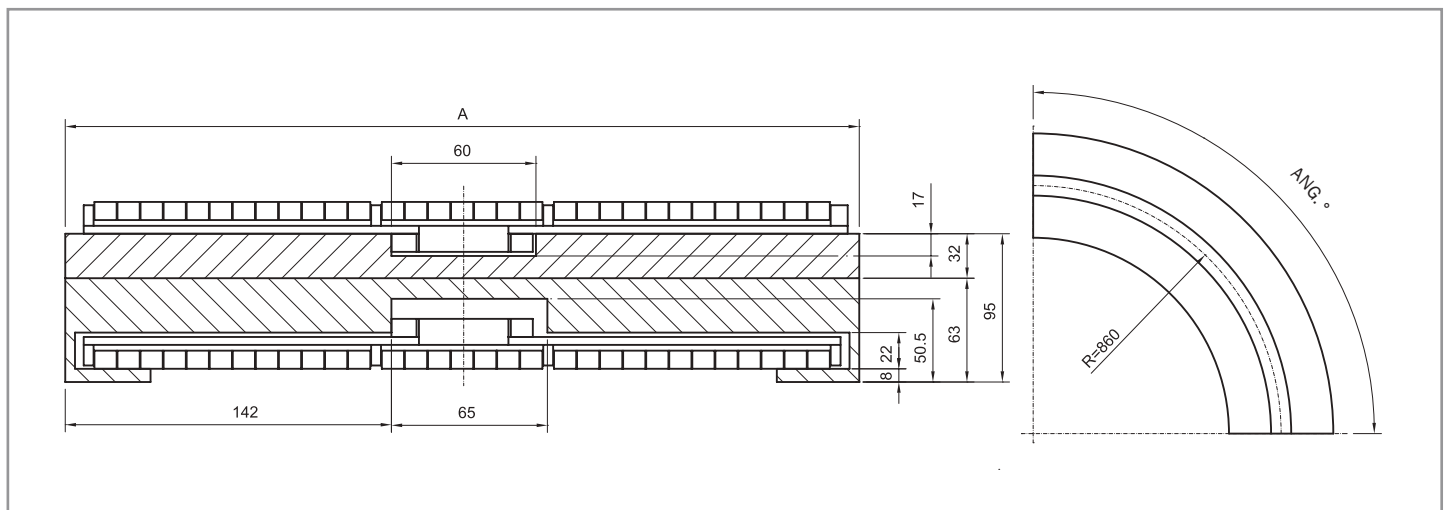

VERSION CMP96

CHAINS REF.

Nr. of Tracks	A	Curve angle 15°	Curve angle 30°	Curve angle 45°	Curve angle 60°	Curve angle 75°	Curve angle 90°	LBP 882 M K1200
1	340	CMP96 01 15	CMP96 01 30	CMP96 01 45	CMP96 01 60	CMP96 01 75	CMP96 01 90	More than 1 track on request.

magnetic corner tracks

VERSION CMP98C / CMB06

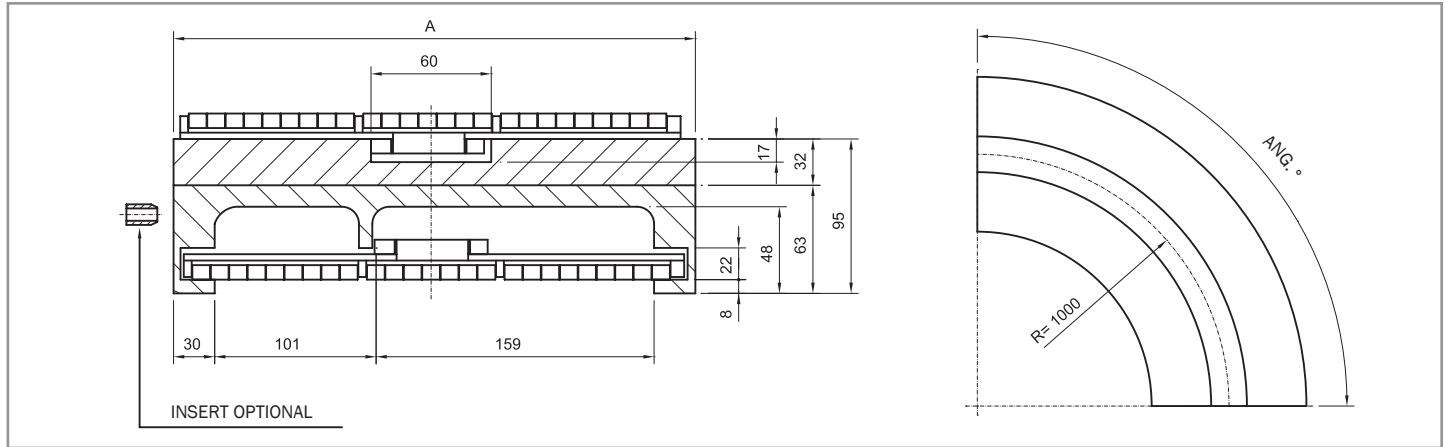

VERSION CMP98C

CHAINS REF.

Nr. of Tracks	A	Curve angle 15°	Curve angle 30°	Curve angle 45°	Curve angle 60°	Curve angle 75°	Curve angle 90°	CHAINS REF.
1	320	CMP98C 01 15	CMP98C 01 30	CMP98C 01 45	CMP98C 01 60	CMP98C 01 75	CMP98C 01 90	LBP 882 M K1200

More than 1 track on request.

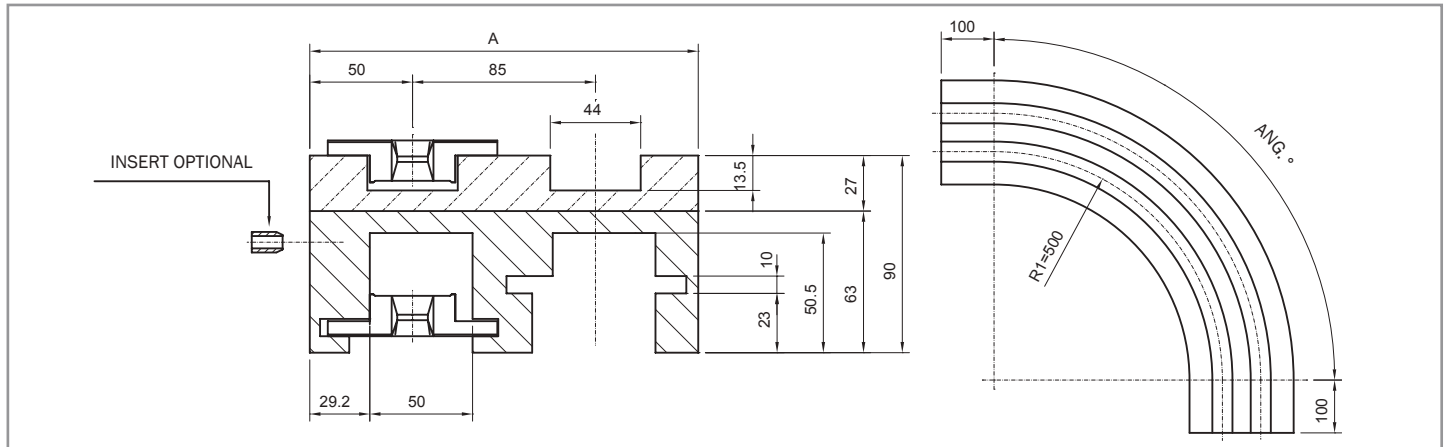

VERSION CMB06

CHAINS REF.

Nr. of Tracks	A	Curve angle 15°	Curve angle 30°	Curve angle 45°	Curve angle 60°	Curve angle 75°	Curve angle 90°	CHAINS REF.
1	100	CMB06 01 15	CMB06 01 30	CMB06 01 45	CMB06 01 60	CMB06 01 75	CMB06 01 90	780 M K330
2	185	CMB06 02 15	CMB06 02 30	CMB06 02 45	CMB06 02 60	CMB06 02 75	CMB06 02 90	
3	270	CMB06 03 15	CMB06 03 30	CMB06 03 45	CMB06 03 60	CMB06 03 75	CMB06 03 90	
4	355	CMB06 04 15	CMB06 04 30	CMB06 04 45	CMB06 04 60	CMB06 04 75	CMB06 04 90	
5	440	CMB06 05 15	CMB06 05 30	CMB06 05 45	CMB06 05 60	CMB06 05 75	CMB06 05 90	
6	525	CMB06 06 15	CMB06 06 30	CMB06 06 45	CMB06 06 60	CMB06 06 75	CMB06 06 90	

More than 6 tracks on request.

magnetic corner tracks

VERSION CMB07 / CMB04

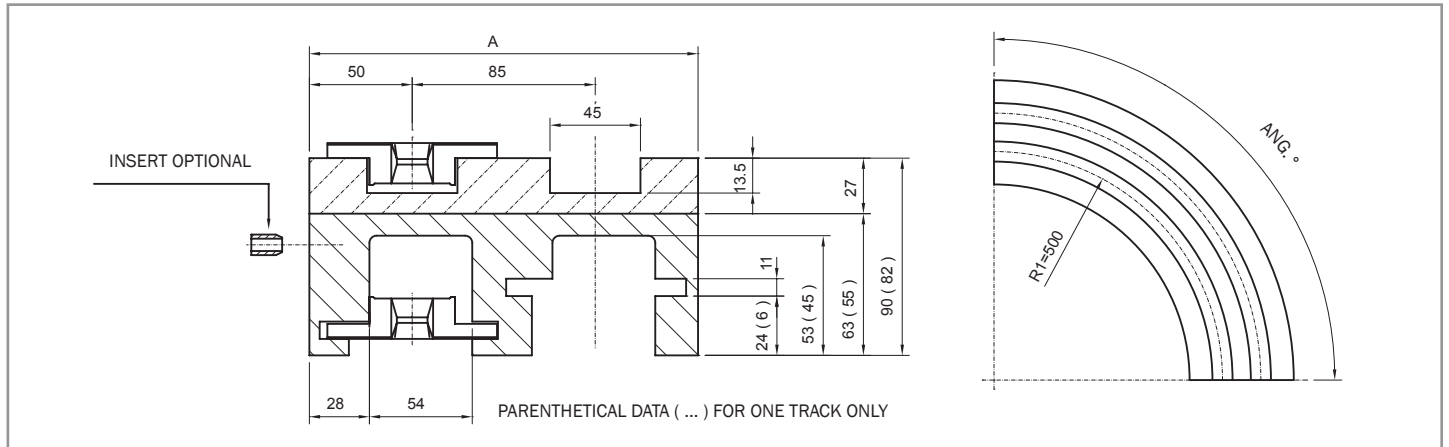

VERSION CMB07

CHAINS REF.

Nr. of Tracks	A	Curve angle								780 M K330
		15°	30°	45°	60°	75°	90°			
1	100	CMB07 01 15	CMB07 01 30	CMB07 01 45	CMB07 01 60	CMB07 01 75	CMB07 01 90			
2	185	CMB07 02 15	CMB07 02 30	CMB07 02 45	CMB07 02 60	CMB07 02 75	CMB07 02 90			
3	270	CMB07 03 15	CMB07 03 30	CMB07 03 45	CMB07 03 60	CMB07 03 75	CMB07 03 90			
4	355	CMB07 04 15	CMB07 04 30	CMB07 04 45	CMB07 04 60	CMB07 04 75	CMB07 04 90			
5	440	CMB07 05 15	CMB07 05 30	CMB07 05 45	CMB07 05 60	CMB07 05 75	CMB07 05 90			
6	525	CMB07 06 15	CMB07 06 30	CMB07 06 45	CMB07 06 60	CMB07 06 75	CMB07 06 90			
7	610	CMB07 07 15	CMB07 07 30	CMB07 07 45	CMB07 07 60	CMB07 07 75	CMB07 07 90			
8	695	CMB07 08 15	CMB07 08 30	CMB07 08 45	CMB07 08 60	CMB07 08 75	CMB07 08 90			

More than 8 tracks on request.

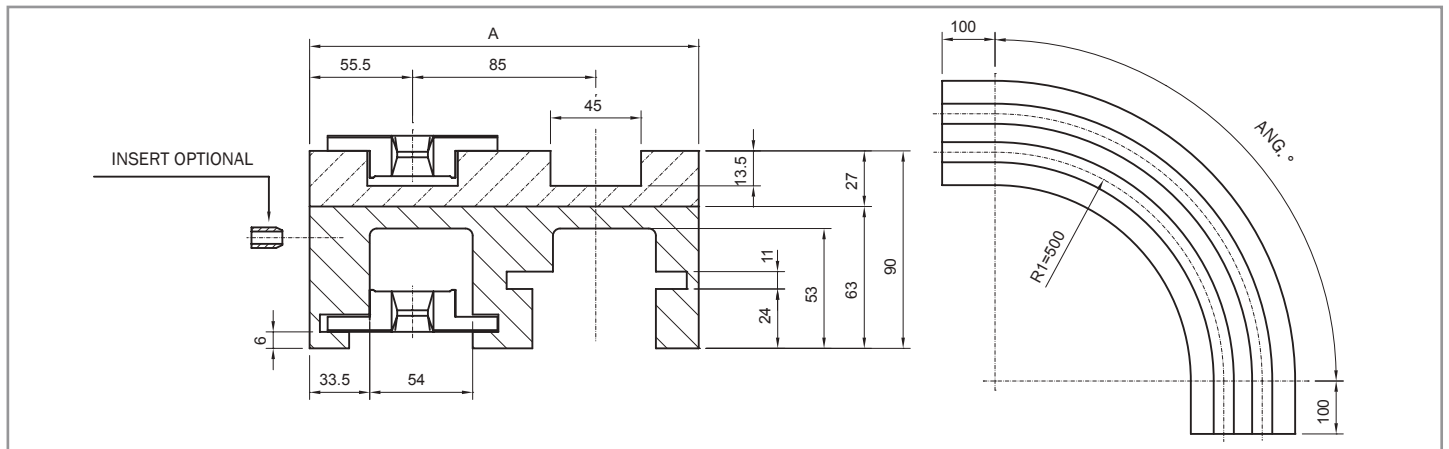

VERSION CMB04

CHAINS REF.

Nr. of Tracks	A	Curve angle								780 M K330
		15°	30°	45°	60°	75°	90°			
1	111	CMB04 01 15	CMB04 01 30	CMB04 01 45	CMB04 01 60	CMB04 01 75	CMB04 01 90			
2	196	CMB04 02 15	CMB04 02 30	CMB04 02 45	CMB04 02 60	CMB04 02 75	CMB04 02 90			
3	281	CMB04 03 15	CMB04 03 30	CMB04 03 45	CMB04 03 60	CMB04 03 75	CMB04 03 90			
4	366	CMB04 04 15	CMB04 04 30	CMB04 04 45	CMB04 04 60	CMB04 04 75	CMB04 04 90			
5	451	CMB04 05 15	CMB04 05 30	CMB04 05 45	CMB04 05 60	CMB04 05 75	CMB04 05 90			
6	536	CMB04 06 15	CMB04 06 30	CMB04 06 45	CMB04 06 60	CMB04 06 75	CMB04 06 90			
7	621	CMB04 07 15	CMB04 07 30	CMB04 07 45	CMB04 07 60	CMB04 07 75	CMB04 07 90			
8	706	CMB04 08 15	CMB04 08 30	CMB04 08 45	CMB04 08 60	CMB04 08 75	CMB04 08 90			

More than 8 tracks on request.

magnetic corner tracks

VERSION CMB08 / CMB05D

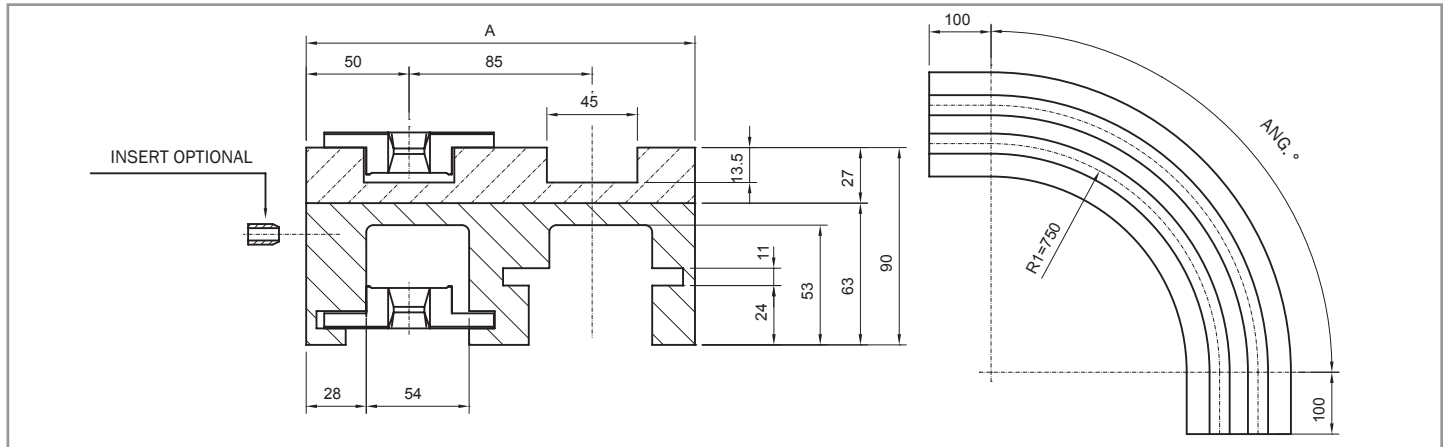

VERSION CMB08

CHAINS REF.

Nr. of Tracks	A	VERSION CMB08						CHAINS REF.
		Curve angle 15°	Curve angle 30°	Curve angle 45°	Curve angle 60°	Curve angle 75°	Curve angle 90°	
1	100	CMB08 01 15	CMB08 01 30	CMB08 01 45	CMB08 01 60	CMB08 01 75	CMB08 01 90	780 M K330 More than 8 tracks on request.
2	185	CMB08 02 15	CMB08 02 30	CMB08 02 45	CMB08 02 60	CMB08 02 75	CMB08 02 90	
3	270	CMB08 03 15	CMB08 03 30	CMB08 03 45	CMB08 03 60	CMB08 03 75	CMB08 03 90	
4	355	CMB08 04 15	CMB08 04 30	CMB08 04 45	CMB08 04 60	CMB08 04 75	CMB08 04 90	
5	440	CMB08 05 15	CMB08 05 30	CMB08 05 45	CMB08 05 60	CMB08 05 75	CMB08 05 90	
6	525	CMB08 06 15	CMB08 06 30	CMB08 06 45	CMB08 06 60	CMB08 06 75	CMB08 06 90	
7	610	CMB08 07 15	CMB08 07 30	CMB08 07 45	CMB08 07 60	CMB08 07 75	CMB08 07 90	
8	695	CMB08 08 15	CMB08 08 30	CMB08 08 45	CMB08 08 60	CMB08 08 75	CMB08 08 90	

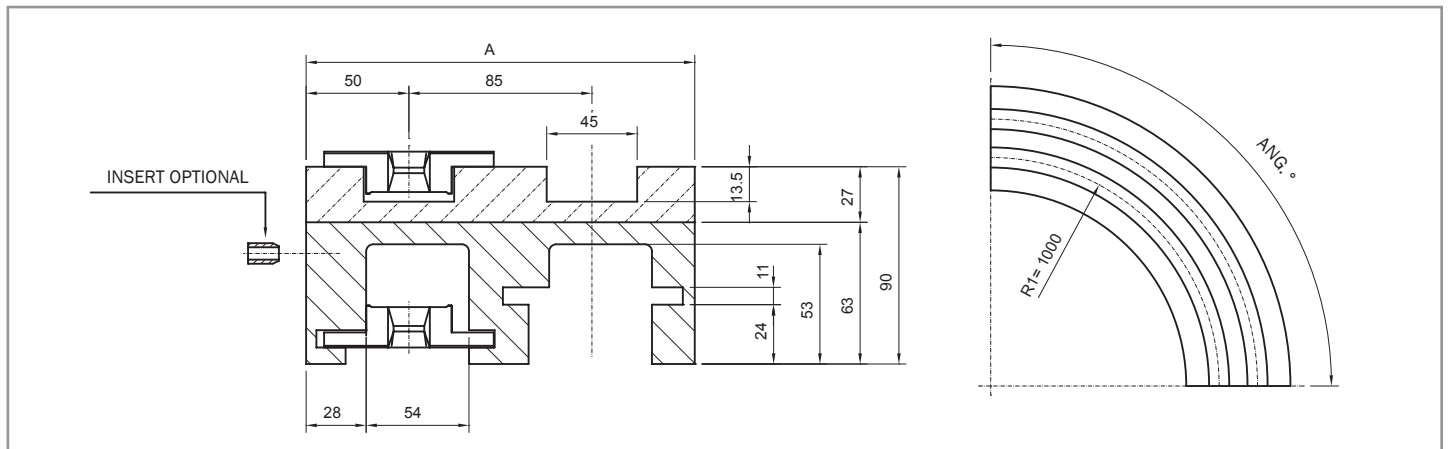

VERSION CMB05D

CHAINS REF.

Nr. of Tracks	A	VERSION CMB05D						CHAINS REF.
		Curve angle 15°	Curve angle 30°	Curve angle 45°	Curve angle 60°	Curve angle 75°	Curve angle 90°	
1	100	CMB05D 01 15	CMB05D 01 30	CMB05D 01 45	CMB05D 01 60	CMB05D 01 75	CMB05D 01 90	780 M K330 More than 8 tracks on request.
2	185	CMB05D 02 15	CMB05D 02 30	CMB05D 02 45	CMB05D 02 60	CMB05D 02 75	CMB05D 02 90	
3	270	CMB05D 03 15	CMB05D 03 30	CMB05D 03 45	CMB05D 03 60	CMB05D 03 75	CMB05D 03 90	
4	355	CMB05D 04 15	CMB05D 04 30	CMB05D 04 45	CMB05D 04 60	CMB05D 04 75	CMB05D 04 90	
5	440	CMB05D 05 15	CMB05D 05 30	CMB05D 05 45	CMB05D 05 60	CMB05D 05 75	CMB05D 05 90	
6	525	CMB05D 06 15	CMB05D 06 30	CMB05D 06 45	CMB05D 06 60	CMB05D 06 75	CMB05D 06 90	
7	610	CMB05D 07 15	CMB05D 07 30	CMB05D 07 45	CMB05D 07 60	CMB05D 07 75	CMB05D 07 90	
8	695	CMB05D 08 15	CMB05D 08 30	CMB05D 08 45	CMB05D 08 60	CMB05D 08 75	CMB05D 08 90	

magnetic corner tracks

VERSION CMB22 / CMB27

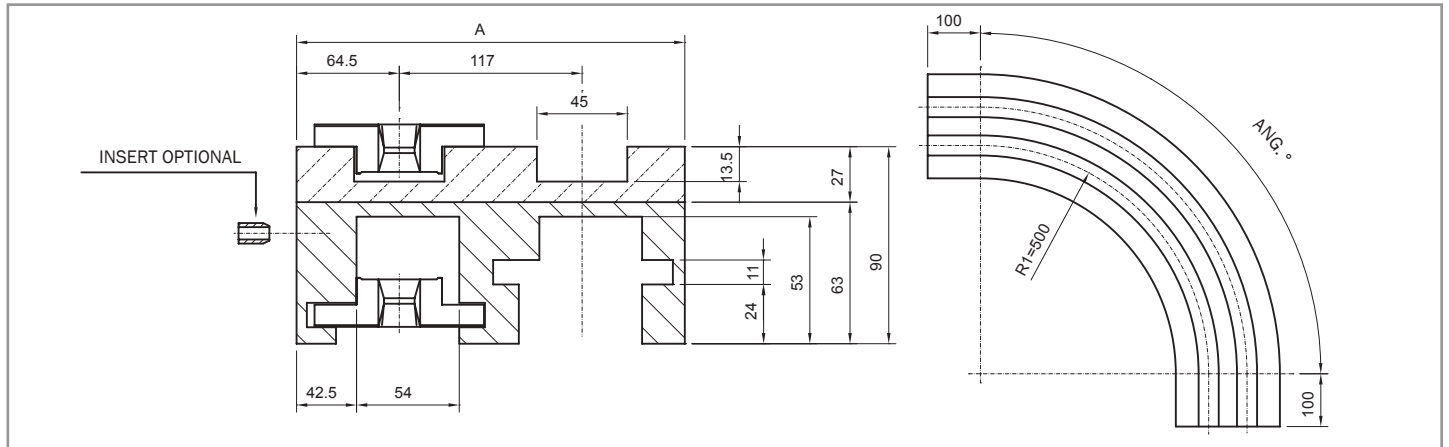

VERSION CMB22

CHAINS REF.

Nr. of Tracks	A	Curve angle						780 M K450
		15°	30°	45°	60°	75°	90°	
1	129	CMB22 01 15	CMB22 01 30	CMB22 01 45	CMB22 01 60	CMB22 01 75	CMB22 01 90	More than 4 tracks on request.
2	246	CMB22 02 15	CMB22 02 30	CMB22 02 45	CMB22 02 60	CMB22 02 75	CMB22 02 90	
3	363	CMB22 03 15	CMB22 03 30	CMB22 03 45	CMB22 03 60	CMB22 03 75	CMB22 03 90	
4	480	CMB22 04 15	CMB22 04 30	CMB22 04 45	CMB22 04 60	CMB22 04 75	CMB22 04 90	

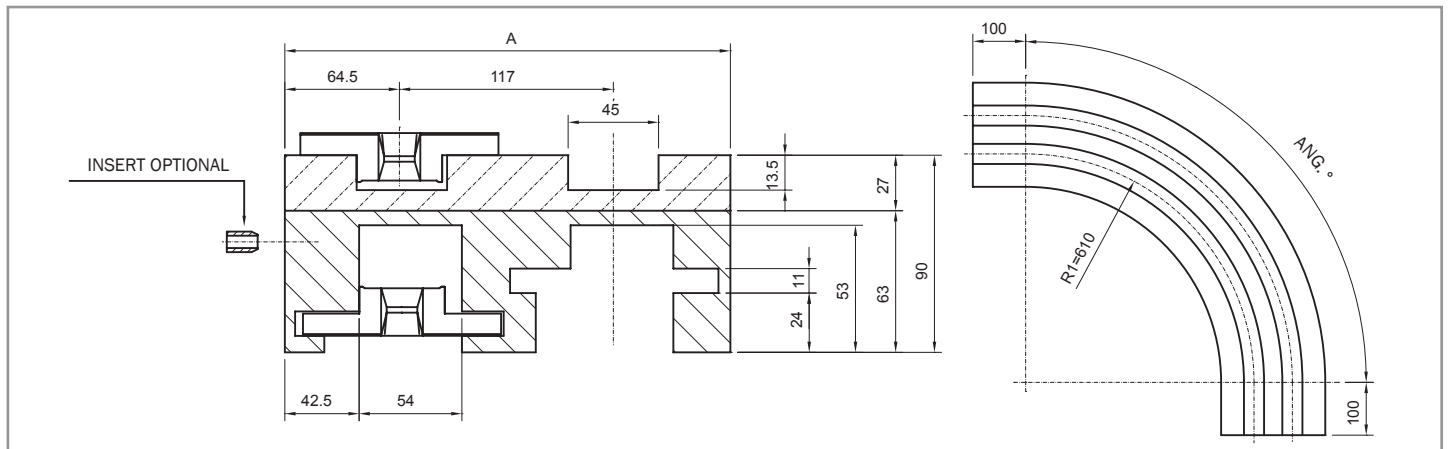

VERSION CMB27

CHAINS REF.

Nr. of Tracks	A	Curve angle						780 M K450
		15°	30°	45°	60°	75°	90°	
1	129	CMB27 01 15	CMB27 01 30	CMB27 01 45	CMB27 01 60	CMB27 01 75	CMB27 01 90	More than 4 tracks on request.
2	246	CMB27 02 15	CMB27 02 30	CMB27 02 45	CMB27 02 60	CMB27 02 75	CMB27 02 90	
3	363	CMB27 03 15	CMB27 03 30	CMB27 03 45	CMB27 03 60	CMB27 03 75	CMB27 03 90	
4	480	CMB27 04 15	CMB27 04 30	CMB27 04 45	CMB27 04 60	CMB27 04 75	CMB27 04 90	

magnetic corner tracks

VERSION CMC06 / CMC07

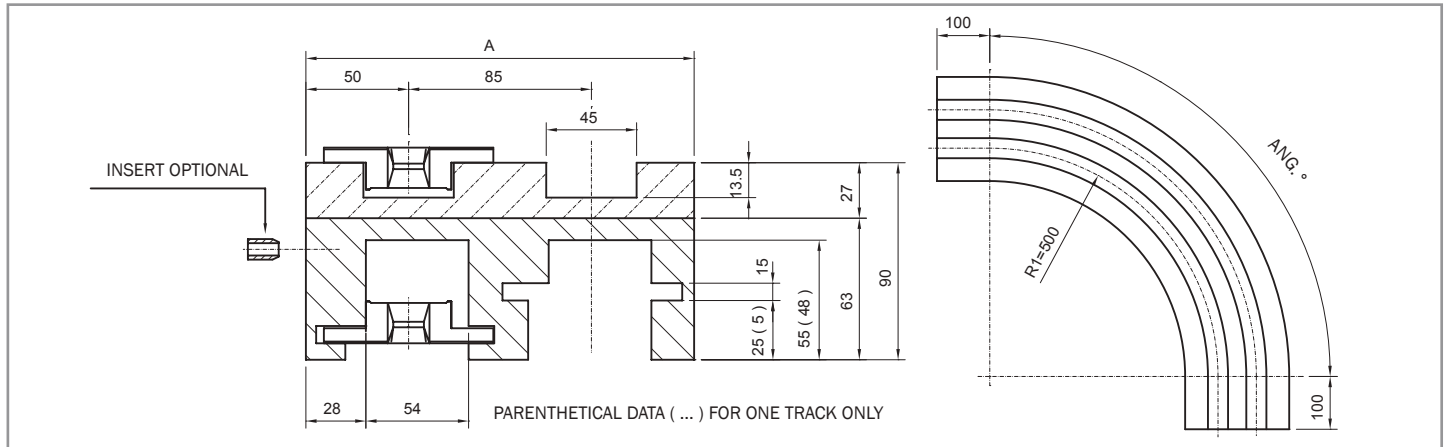

VERSION CMC06

CHAINS REF.

Nr. of Tracks	A	Curve angle						790 M K330
		15°	30°	45°	60°	75°	90°	
1	100	CMC06 01 15	CMC06 01 30	CMC06 01 45	CMC06 01 60	CMC06 01 75	CMC06 01 90	More than 8 tracks on request.
2	185	CMC06 02 15	CMC06 02 30	CMC06 02 45	CMC06 02 60	CMC06 02 75	CMC06 02 90	
3	270	CMC06 03 15	CMC06 03 30	CMC06 03 45	CMC06 03 60	CMC06 03 75	CMC06 03 90	
4	355	CMC06 04 15	CMC06 04 30	CMC06 04 45	CMC06 04 60	CMC06 04 75	CMC06 04 90	
5	440	CMC06 05 15	CMC06 05 30	CMC06 05 45	CMC06 05 60	CMC06 05 75	CMC06 05 90	
6	525	CMC06 06 15	CMC06 06 30	CMC06 06 45	CMC06 06 60	CMC06 06 75	CMC06 06 90	
7	610	CMC06 07 15	CMC06 07 30	CMC06 07 45	CMC06 07 60	CMC06 07 75	CMC06 07 90	
8	695	CMC06 08 15	CMC06 08 30	CMC06 08 45	CMC06 08 60	CMC06 08 75	CMC06 08 90	

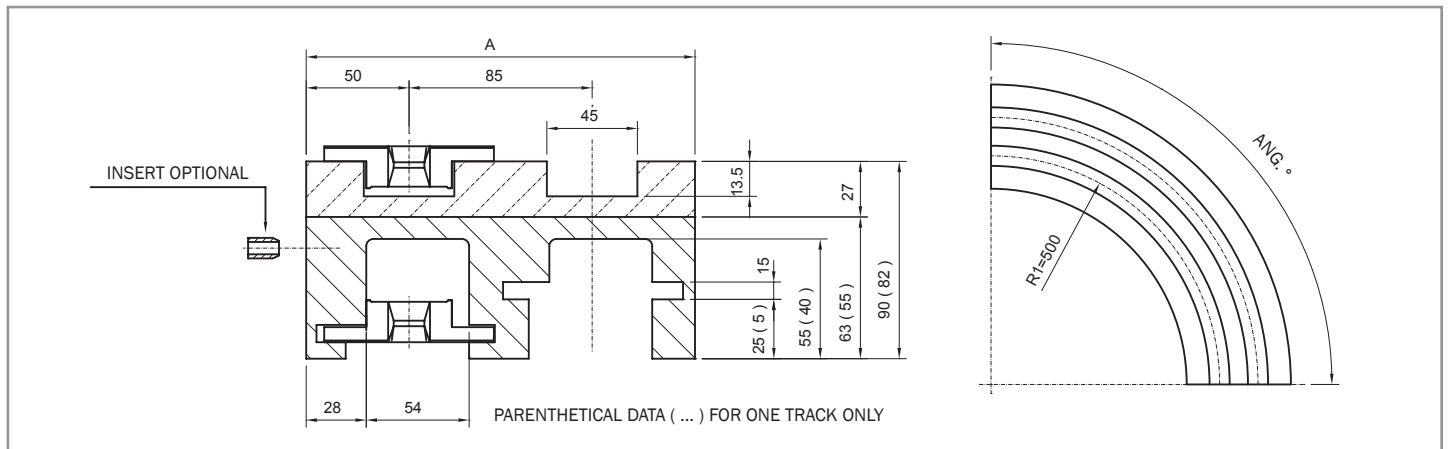

VERSION CMC07

CHAINS REF.

Nr. of Tracks	A	Curve angle						790 M K330
		15°	30°	45°	60°	75°	90°	
1	100	CMC07 01 15	CMC07 01 30	CMC07 01 45	CMC07 01 60	CMC07 01 75	CMC07 01 90	More than 8 tracks on request.
2	185	CMC07 02 15	CMC07 02 30	CMC07 02 45	CMC07 02 60	CMC07 02 75	CMC07 02 90	
3	270	CMC07 03 15	CMC07 03 30	CMC07 03 45	CMC07 03 60	CMC07 03 75	CMC07 03 90	
4	355	CMC07 04 15	CMC07 04 30	CMC07 04 45	CMC07 04 60	CMC07 04 75	CMC07 04 90	
5	440	CMC07 05 15	CMC07 05 30	CMC07 05 45	CMC07 05 60	CMC07 05 75	CMC07 05 90	
6	525	CMC07 06 15	CMC07 06 30	CMC07 06 45	CMC07 06 60	CMC07 06 75	CMC07 06 90	
7	610	CMC07 07 15	CMC07 07 30	CMC07 07 45	CMC07 07 60	CMC07 07 75	CMC07 07 90	
8	695	CMC07 08 15	CMC07 08 30	CMC07 08 45	CMC07 08 60	CMC07 08 75	CMC07 08 90	

magnetic corner tracks

VERSION CMC04 / CMC08

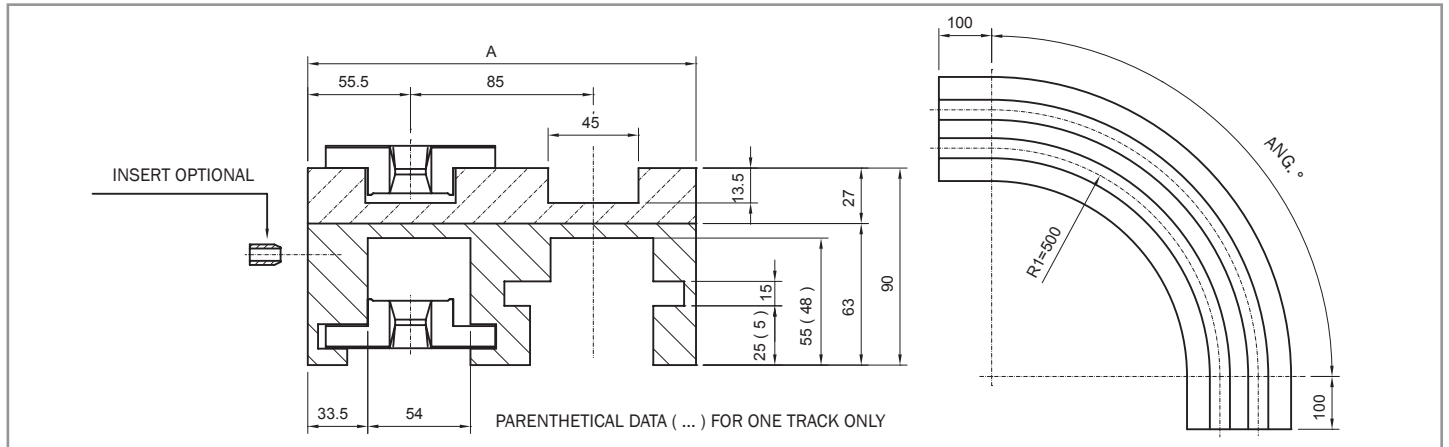

VERSION CMC04

CHAINS REF.

Nr. of Tracks	A	CHAINS REF.							
		Curve angle 15°	Curve angle 30°	Curve angle 45°	Curve angle 60°	Curve angle 75°	Curve angle 90°	790 M K330	
1	111	CMC04 01 15	CMC04 01 30	CMC04 01 45	CMC04 01 60	CMC04 01 75	CMC04 01 90		
2	196	CMC04 02 15	CMC04 02 30	CMC04 02 45	CMC04 02 60	CMC04 02 75	CMC04 02 90		
3	281	CMC04 03 15	CMC04 03 30	CMC04 03 45	CMC04 03 60	CMC04 03 75	CMC04 03 90		
4	366	CMC04 04 15	CMC04 04 30	CMC04 04 45	CMC04 04 60	CMC04 04 75	CMC04 04 90		
5	451	CMC04 05 15	CMC04 05 30	CMC04 05 45	CMC04 05 60	CMC04 05 75	CMC04 05 90		
6	536	CMC04 06 15	CMC04 06 30	CMC04 06 45	CMC04 06 60	CMC04 06 75	CMC04 06 90		
7	621	CMC04 07 15	CMC04 07 30	CMC04 07 45	CMC04 07 60	CMC04 07 75	CMC04 07 90		
8	706	CMC04 08 15	CMC04 08 30	CMC04 08 45	CMC04 08 60	CMC04 08 75	CMC04 08 90	More than 8 tracks on request.	

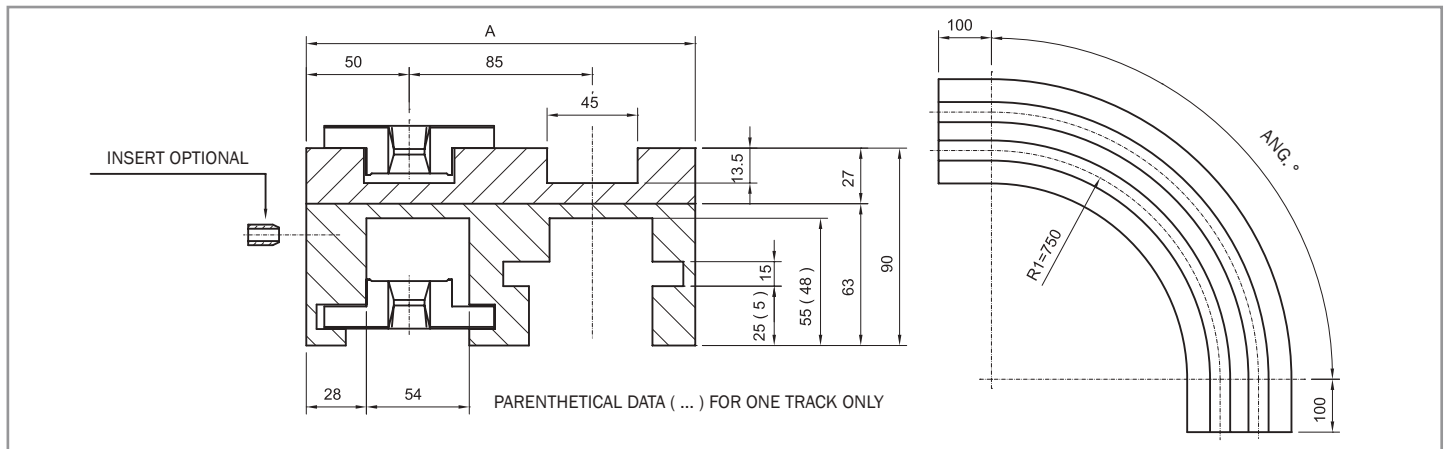

VERSION CMC08

CHAINS REF.

Nr. of Tracks	A	CHAINS REF.							
		Curve angle 15°	Curve angle 30°	Curve angle 45°	Curve angle 60°	Curve angle 75°	Curve angle 90°	790 M K330	
1	100	CMC08 01 15	CMC08 01 30	CMC08 01 45	CMC08 01 60	CMC08 01 75	CMC08 01 90		
2	185	CMC08 02 15	CMC08 02 30	CMC08 02 45	CMC08 02 60	CMC08 02 75	CMC08 02 90		
3	270	CMC08 03 15	CMC08 03 30	CMC08 03 45	CMC08 03 60	CMC08 03 75	CMC08 03 90		
4	355	CMC08 04 15	CMC08 04 30	CMC08 04 45	CMC08 04 60	CMC08 04 75	CMC08 04 90		
5	440	CMC08 05 15	CMC08 05 30	CMC08 05 45	CMC08 05 60	CMC08 05 75	CMC08 05 90		
6	525	CMC08 06 15	CMC08 06 30	CMC08 06 45	CMC08 06 60	CMC08 06 75	CMC08 06 90		
7	610	CMC08 07 15	CMC08 07 30	CMC08 07 45	CMC08 07 60	CMC08 07 75	CMC08 07 90		
8	695	CMC08 08 15	CMC08 08 30	CMC08 08 45	CMC08 08 60	CMC08 08 75	CMC08 08 90	More than 8 tracks on request.	

magnetic corner tracks

VERSION CMC05D / CMC21

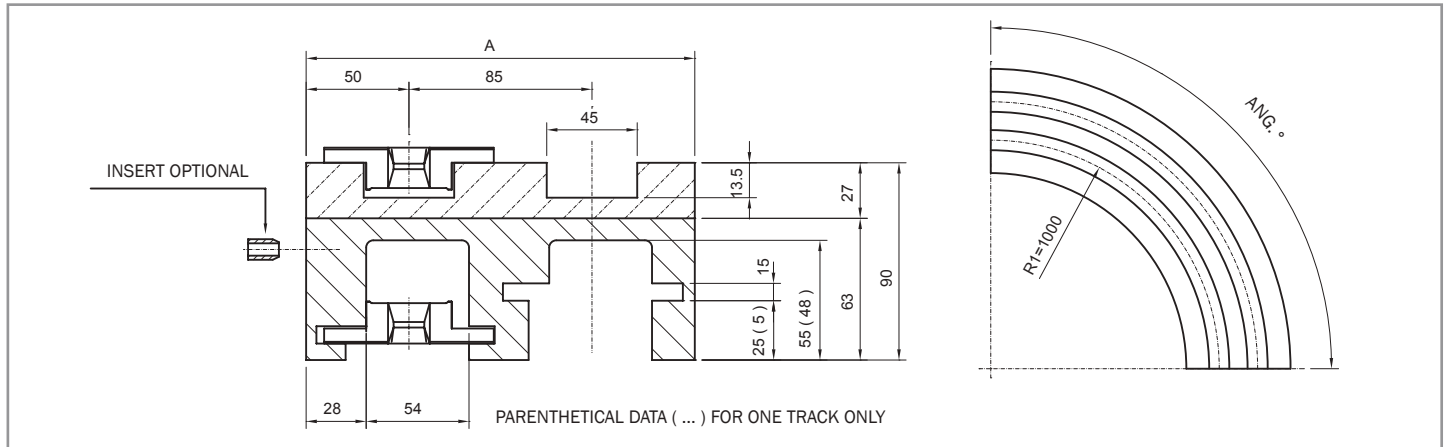

VERSION CMC05D

CHAINS REF.

Nr. of Tracks	A	CHAINS REF.							
		Curve angle 15°	Curve angle 30°	Curve angle 45°	Curve angle 60°	Curve angle 75°	Curve angle 90°	790 M K330	
1	100	CMC05D 01 15	CMC05D 01 30	CMC05D 01 45	CMC05D 01 60	CMC05D 01 75	CMC05D 01 90		
2	185	CMC05D 02 15	CMC05D 02 30	CMC05D 02 45	CMC05D 02 60	CMC05D 02 75	CMC05D 02 90		
3	270	CMC05D 03 15	CMC05D 03 30	CMC05D 03 45	CMC05D 03 60	CMC05D 03 75	CMC05D 03 90		
4	355	CMC05D 04 15	CMC05D 04 30	CMC05D 04 45	CMC05D 04 60	CMC05D 04 75	CMC05D 04 90		
5	440	CMC05D 05 15	CMC05D 05 30	CMC05D 05 45	CMC05D 05 60	CMC05D 05 75	CMC05D 05 90		
6	525	CMC05D 06 15	CMC05D 06 30	CMC05D 06 45	CMC05D 06 60	CMC05D 06 75	CMC05D 06 90		
7	610	CMC05D 07 15	CMC05D 07 30	CMC05D 07 45	CMC05D 07 60	CMC05D 07 75	CMC05D 07 90		
8	695	CMC05D 08 15	CMC05D 08 30	CMC05D 08 45	CMC05D 08 60	CMC05D 08 75	CMC05D 08 90	More than 8 tracks on request.	

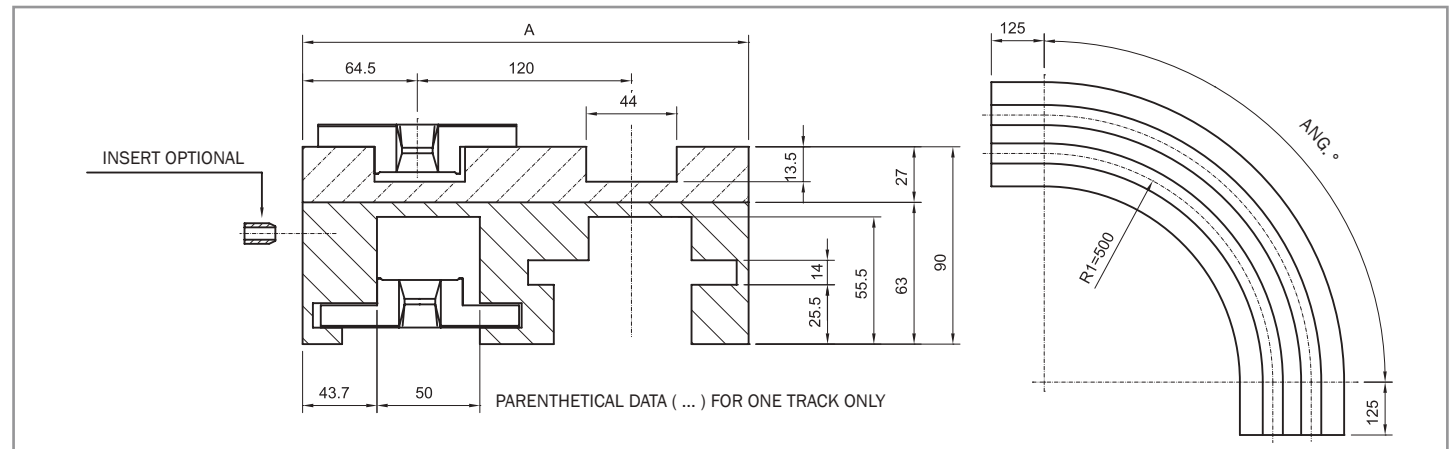

VERSION CMC21

CHAINS REF.

Nr. of Tracks	A	CHAINS REF.							
		Curve angle 15°	Curve angle 30°	Curve angle 45°	Curve angle 60°	Curve angle 75°	Curve angle 90°	790 M K450	
1	129	CMC21 01 15	CMC21 01 30	CMC21 01 45	CMC21 01 60	CMC21 01 75	CMC21 01 90		
2	249	CMC21 02 15	CMC21 02 30	CMC21 02 45	CMC21 02 60	CMC21 02 75	CMC21 02 90		
3	369	CMC21 03 15	CMC21 03 30	CMC21 03 45	CMC21 03 60	CMC21 03 75	CMC21 03 90		
4	489	CMC21 04 15	CMC21 04 30	CMC21 04 45	CMC21 04 60	CMC21 04 75	CMC21 04 90	More than 4 tracks on request.	

magnetic corner tracks

VERSION CMC22 / CMC27

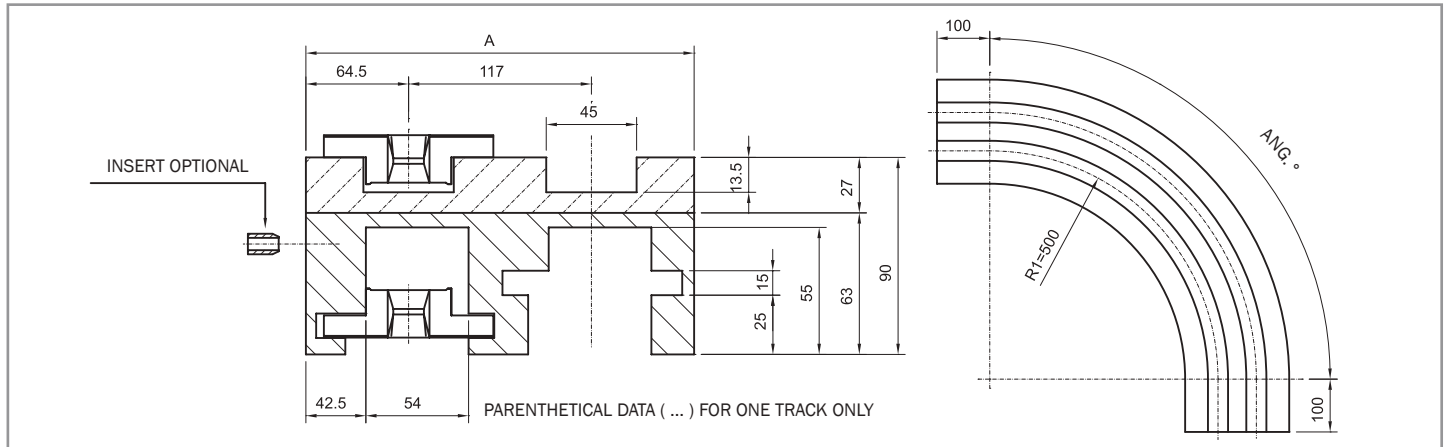

VERSION CMC22

CHAINS REF.

Nr. of Tracks	A	Curve angle						790 M K450
		15°	30°	45°	60°	75°	90°	
1	129	CMC22 01 15	CMC22 01 30	CMC22 01 45	CMC22 01 60	CMC22 01 75	CMC22 01 90	More than 4 tracks on request.
2	246	CMC22 02 15	CMC22 02 30	CMC22 02 45	CMC22 02 60	CMC22 02 75	CMC22 02 90	
3	363	CMC22 03 15	CMC22 03 30	CMC22 03 45	CMC22 03 60	CMC22 03 75	CMC22 03 90	
4	480	CMC22 04 15	CMC22 04 30	CMC22 04 45	CMC22 04 60	CMC22 04 75	CMC22 04 90	

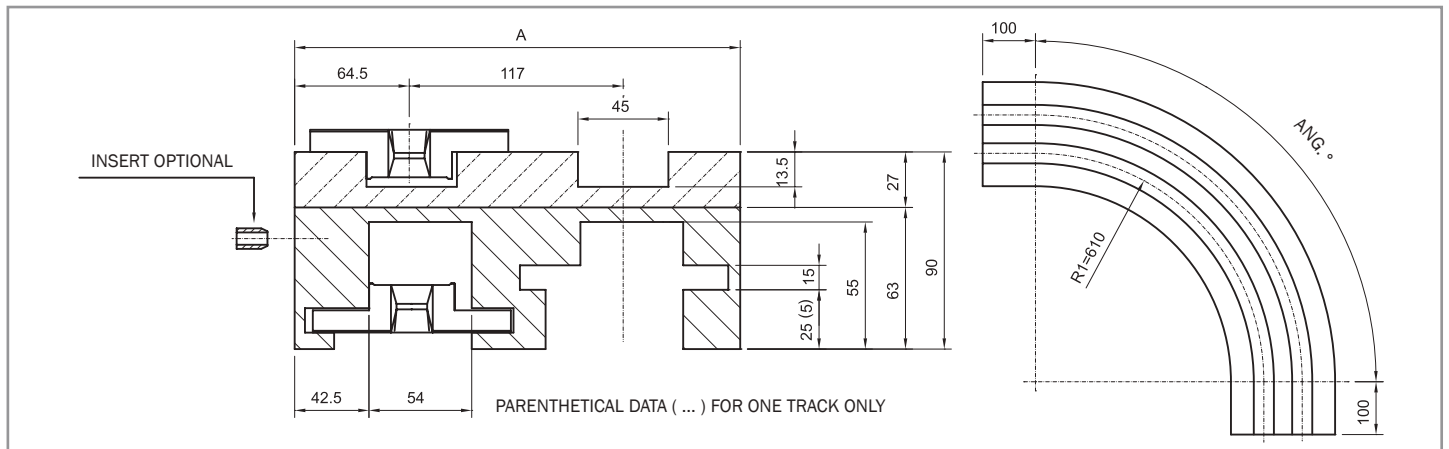

VERSION CMC27

CHAINS REF.

Nr. of Tracks	A	Curve angle						790 M K450
		15°	30°	45°	60°	75°	90°	
1	129	CMC27 01 15	CMC27 01 30	CMC27 01 45	CMC27 01 60	CMC27 01 75	CMC27 01 90	More than 4 tracks on request.
2	246	CMC27 02 15	CMC27 02 30	CMC27 02 45	CMC27 02 60	CMC27 02 75	CMC27 02 90	
3	363	CMC27 03 15	CMC27 03 30	CMC27 03 45	CMC27 03 60	CMC27 03 75	CMC27 03 90	
4	480	CMC27 04 15	CMC27 04 30	CMC27 04 45	CMC27 04 60	CMC27 04 75	CMC27 04 90	

magnetic corner tracks

RETURN GUIDE

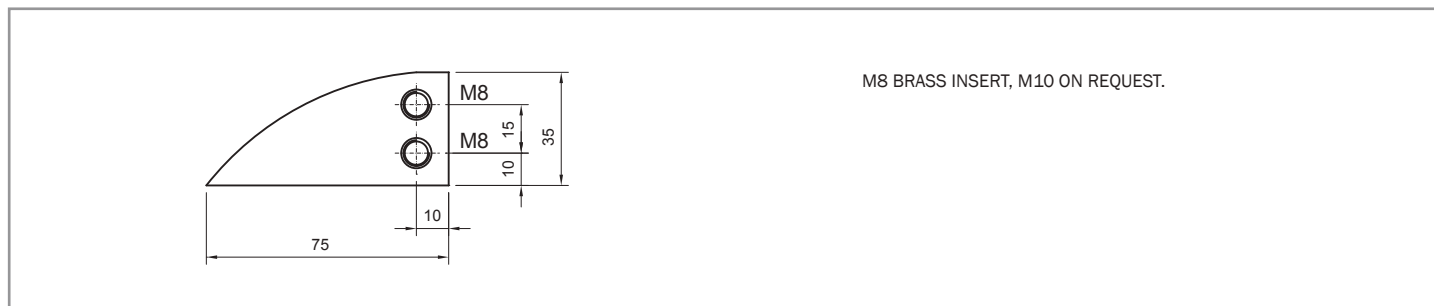

M8 brass insert, M10 on request.

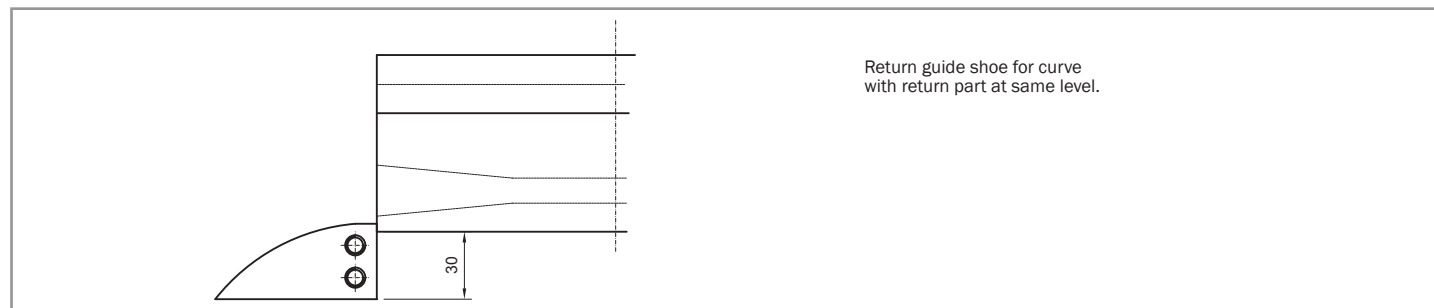

Return guide shoe for curve with return part at same level.

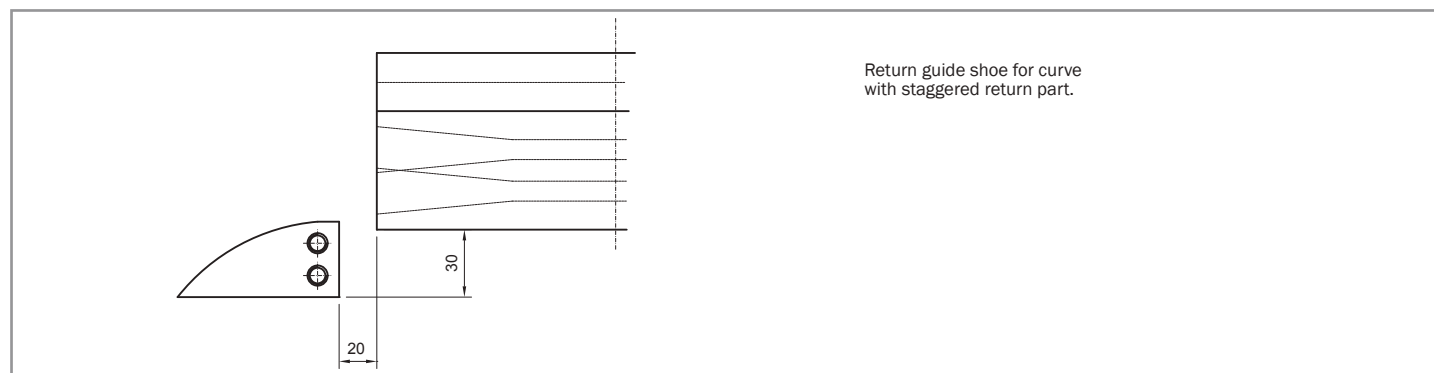

Return guide shoe for curve with staggered return part.

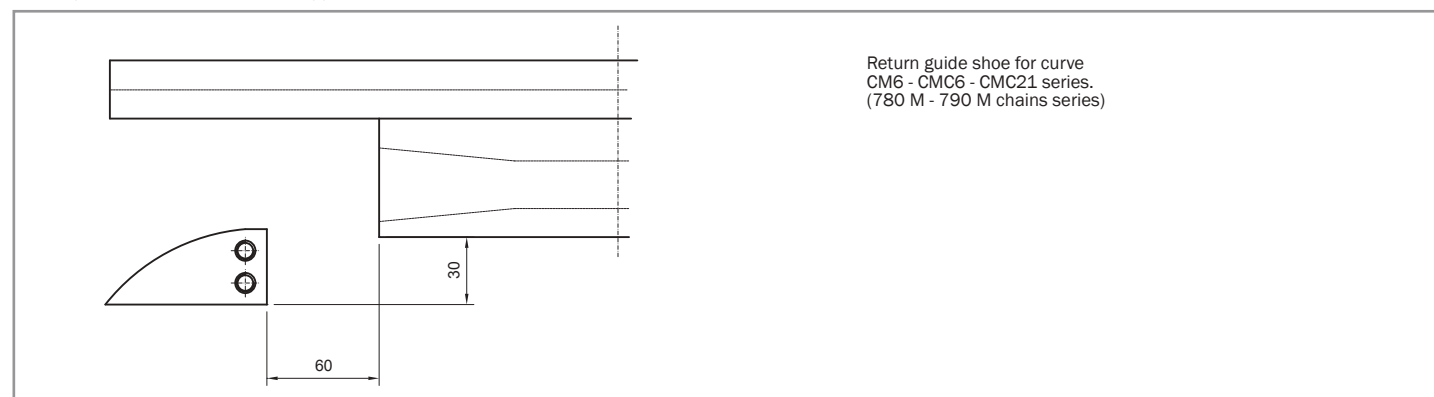

Return guide shoe for curve CM6 - CMC6 - CMC21 series (780 M - 790 M chains series).

Алматы (727)345-47-04
Ангарск (3955)60-70-56
Архангельск (8182)63-90-72
Астрахань (8512)99-46-04
Барнаул (3852)73-04-60
Белгород (4722)40-23-64
Благовещенск (4162)22-76-07
Брянск (4832)59-03-52
Владивосток (423)249-28-31
Владикавказ (8672)28-90-48
Владимир (4922)49-43-18
Волгоград (844)278-03-48
Вологда (8172)26-41-59
Воронеж (473)204-51-73
Екатеринбург (343)384-55-89

Иваново (4932)77-34-06
Ижевск (3412)26-03-58
Иркутск (395)279-98-46
Казань (843)206-01-48
Калининград (4012)72-03-81
Калуга (4842)92-23-67
Кемерово (3842)65-04-62
Киров (8332)68-02-04
Коломна (4966)23-41-49
Кострома (4942)77-07-48
Краснодар (861)203-40-90
Красноярск (391)204-63-61
Курск (4712)77-13-04
Курган (3522)50-90-47
Липецк (4742)52-20-81

Магнитогорск (3519)55-03-13
Москва (495)268-04-70
Мурманск (8152)59-64-93
Набережные Челны (8552)20-53-41
Новокузнецк (3843)20-46-81
Новосибирск (383)227-86-73
Омск (3812)21-46-40
Орел (4862)44-53-42
Оренбург (3532)37-68-04
Пенза (8412)22-31-16
Петрозаводск (8142)55-98-37
Псков (8112)59-10-37
Пермь (342)205-81-47

Ростов-на-Дону (863)308-18-15
Рязань (4912)46-61-64
Самара (846)206-03-16
Санкт-Петербург (812)309-46-40
Саратов (845)249-38-78
Севастополь (8692)22-31-93
Саранск (8342)22-96-24
Симферополь (3652)67-13-56
Смоленск (4812)29-41-54
Сочи (862)225-72-31
Ставрополь (8652)20-65-13
Сургут (3462)77-98-35
Сыктывкар (8212)25-95-17
Тамбов (4752)50-40-97
Тверь (4822)63-31-35

Тольятти (8482)63-91-07
Томск (3822)98-41-53
Тула (4872)33-79-87
Тюмень (3452)66-21-18
Ульяновск (8422)24-23-59
Улан-Удэ (3012)59-97-51
Уфа (347)229-48-12
Хабаровск (4212)92-98-04
Чебоксары (8352)28-53-07
Челябинск (351)202-03-61
Череповец (8202)49-02-64
Чита (3022)38-34-83
Якутск (4112)23-90-97
Ярославль (4852)69-52-93

Россия +7(495)268-04-70

Казахстан +7(727)345-47-04

Беларусь +(375)257-127-884

Узбекистан +998(71)205-18-59

Киргизия +996(312)96-26-47