

Алматы (727)345-47-04
Ангарск (3955)60-70-56
Архангельск (8182)63-90-72
Астрахань (8512)99-46-04
Барнаул (3852)73-04-60
Белгород (4722)40-23-64
Благовещенск (4162)22-76-07
Брянск (4832)59-03-52
Владивосток (423)249-28-31
Владикавказ (8672)28-90-48
Владимир (4922)49-43-18
Волгоград (844)278-03-48
Вологда (8172)26-41-59
Воронеж (473)204-51-73
Екатеринбург (343)384-55-89

Иваново (4932)77-34-06
Ижевск (3412)26-03-58
Иркутск (395)279-98-46
Казань (843)206-01-48
Калининград (4012)72-03-81
Калуга (4842)92-23-67
Кемерово (3842)65-04-62
Киров (8332)68-02-04
Коломна (4966)23-41-49
Кострома (4942)77-07-48
Краснодар (861)203-40-90
Красноярск (391)204-63-61
Курск (4712)77-13-04
Курган (3522)50-90-47
Липецк (4742)52-20-81

Магнитогорск (3519)55-03-13
Москва (495)268-04-70
Мурманск (8152)59-64-93
Набережные Челны (8552)20-53-41
Нижний Новгород (831)429-08-12
Новокузнецк (3843)20-46-81
Ноябрьск (3496)41-32-12
Новосибирск (383)227-86-73
Омск (3812)21-46-40
Орел (4862)44-53-42
Оренбург (3532)37-68-04
Пенза (8412)22-31-16
Петрозаводск (8142)55-98-37
Псков (8112)59-10-37
Пермь (342)205-81-47

Ростов-на-Дону (863)308-18-15
Рязань (4912)46-61-64
Самара (846)206-03-16
Санкт-Петербург (812)309-46-40
Саратов (845)249-38-78
Севастополь (8692)22-31-93
Саранск (8342)22-96-24
Симферополь (3652)67-13-56
Смоленск (4812)29-41-54
Сочи (862)225-72-31
Ставрополь (8652)20-65-13
Сургут (3462)77-98-35
Сыктывкар (8212)25-95-17
Тамбов (4752)50-40-97
Тверь (4822)63-31-35

Тольятти (8482)63-91-07
Томск (3822)98-41-53
Тула (4872)33-79-87
Тюмень (3452)66-21-18
Ульяновск (8422)24-23-59
Улан-Удэ (3012)59-97-51
Уфа (347)229-48-12
Хабаровск (4212)92-98-04
Чебоксары (8352)28-53-07
Челябинск (351)202-03-61
Череповец (8202)49-02-64
Чита (3022)38-34-83
Якутск (4112)23-90-97
Ярославль (4852)69-52-93

Россия +7(495)268-04-70

Казахстан +7(727)345-47-04

Беларусь +(375)257-127-884

Узбекистан +998(71)205-18-59

Киргизия +996(312)96-26-47

<https://magris.nt-rt.ru/> || mgq@nt-rt.ru



Metal Chains ED01

MakesMoving

slats

HARD INOX

Special work hardened, chrome-nickel, highly wear corrosion resistant stainless steel. It offers excellent mechanical characteristics and exceptional sliding properties, thanks to a very low surface roughness. It is particularly suitable for the critical points of bottling lines.

Material used for the following chain models:

Super, Flex RXMS, Flex FMS, Flex FMS2, New Flex Mag, Super G*, Flex RXMS G* and New Flex Mag G*.

Minimum temperatures:

- 40°C

Maximum temperatures:

+ 260°C (dry env.),

+ 120°C (wet env.)

* Minimum temperatures: -10°C

Maximum temperatures: +80°C

INOX 18/8

Austenitic, non-magnetic AISI 304 stainless steel (18% Chrome – 8% Nickel), work hardened for high resistance. It provides excellent resistance to chemical agents and corrosion, and offers excellent mechanical and duration characteristics. It is mainly used in the preservation and bottling industry. Approved by Food and Drug Administration (FDA), American government institute for the direct contact with foodstuff.

Material used for the following chain models:

Stella D, Flex RXM, Flex FM and Flex FM2.

Minimum temperatures:

- 40°C

Maximum temperatures:

+ 400°C (dry env.),

+ 120°C (wet env.)

INOX

Ferritic, AISI 430 stainless steel, work hardened by cold-rolling, with good corrosion resistance. It has an excellent surface finishing with a low roughness, that is a very important quality for the sliding of conveyed products. It is the preferred choice for standard bottling industry applications.

Material used for the following chain models:

Special, Standard, Flex RXMC, Flex FMC and New Flex Mag.

Minimum temperatures:

- 40°C

Maximum temperatures:

+ 260°C (dry env.),

+ 120°C (wet env.)

INOX 316

Austenitic AISI 316L stainless steel (18% Chrome – 14% Nickel – 3% Molybdenum). It is ideal with chemical agents and strong acids.

Material used for the following chain models:

316 and Flex RXM 316.

Minimum temperatures:

- 40°C

Maximum temperatures:

+ 400°C (dry env.),

+ 120°C (wet env.)

HQ INOX (high quality)

Special, new, chrome-nickel (W.1.4589) stainless steel, work hardened. It has been developed in cooperation with a major stainless steel manufacturer for very special applications such as pressureless combiners/inliners. Cold rolled to extremely high quality standards, this material is the right answer to the most sophisticated needs. Its exceptional surface finishing and flatness together with a very high working load and wear resistance are unique features.

Material used for the following chain models:

Superspeed, Wear-Proof, Flex FMD and New Flex Mag D.

Minimum temperatures:

- 40°C

Maximum temperatures:

+ 260°C (dry env.),

+ 120°C (wet env.)

CARBON STEEL

Heat-treated carbon steel with a surface and core hardness of 43 HRC. It is especially suitable for high working loads and it is highly resistant to wear. It is recommended for the glass, ceramic and general product conveying industry. In case of difficult applications, such as with abrasive dust, the carbon steel can be, upon request, case-hardened, thus reaching a surface hardness of 55 HRC and a core hardness of 40 HRC.

Material used for the following chain models:

Accate, Flex RXMA and Flex FMA2.

Minimum temperatures:

- 40°C

Maximum temperatures:

+ 180°C (dry env.)

+ 120°C (wet env.)

pins

STANDARD PIN

The following chain models :
Special, Standard, Super, Super G,
Flex RXMC, Flex RXMS, Flex RXMS G,
Flex FMS, Flex FMS2 and New Flex
Mag, have pins made of AISI 431
stainless steel, magnetic and work
hardened for high resistance.

HB PINS

The following chain models :
Wear Proof, Superspeed, Flex FMD
and New Flex Mag D, have pins made
of special martensitic stainless steel,
magnetic and heat-treated for high
resistance.

- Increased wear resistance
- Pins life up to 40% higher

XHB PINS

Special patented hardened pins
series XHB are available upon request.
They offer an additional wear
resistance combined with a higher
corrosion strength.

- Pins life up to 100% higher

AUSTENITIC 18/8 PINS

The following chain models:
Stella D, Flex RXM, Flex FM, Flex FM2
have pins made of austenitic stainless
steel (18% Chrome - 8% Nickel),
work hardened for high resistance.

- Excellent corrosion resistance.

AISI 316 PINS

The following chain models:
316 and Flex RXM 316, have pins made
of austenitic AISI 316 stainless steel.

- Exceptional corrosion resistance.

CASE-HARDENED CARBON STEEL PINS

The following chain models:
Accate, Accate C, Flex RXMA, Flex
RXMA C and Flex FMA2, have pins
made of case-hardened carbon steel.

polished hinges for high speed application

Most of straight running and sideliflexing Magris chains are available with polished hinges.
This increases the performance of the chains on high-speed side transfers, improves
the contact with the side guides and prevents pulsating of the chain raising the stability
of the conveyed products.

NB.: Upon request, all our chains can be produced with other types of stainless steel.

Every care has been taken to ensure the accuracy of the information contained in this catalogue
but no liability can be accepted for any errors or omissions.

SYMBOLS



EXTRA FLAT
Improved flatness for
optimum product stability.



RA
Best surface
finish

straight running chains

SINGLE HINGE

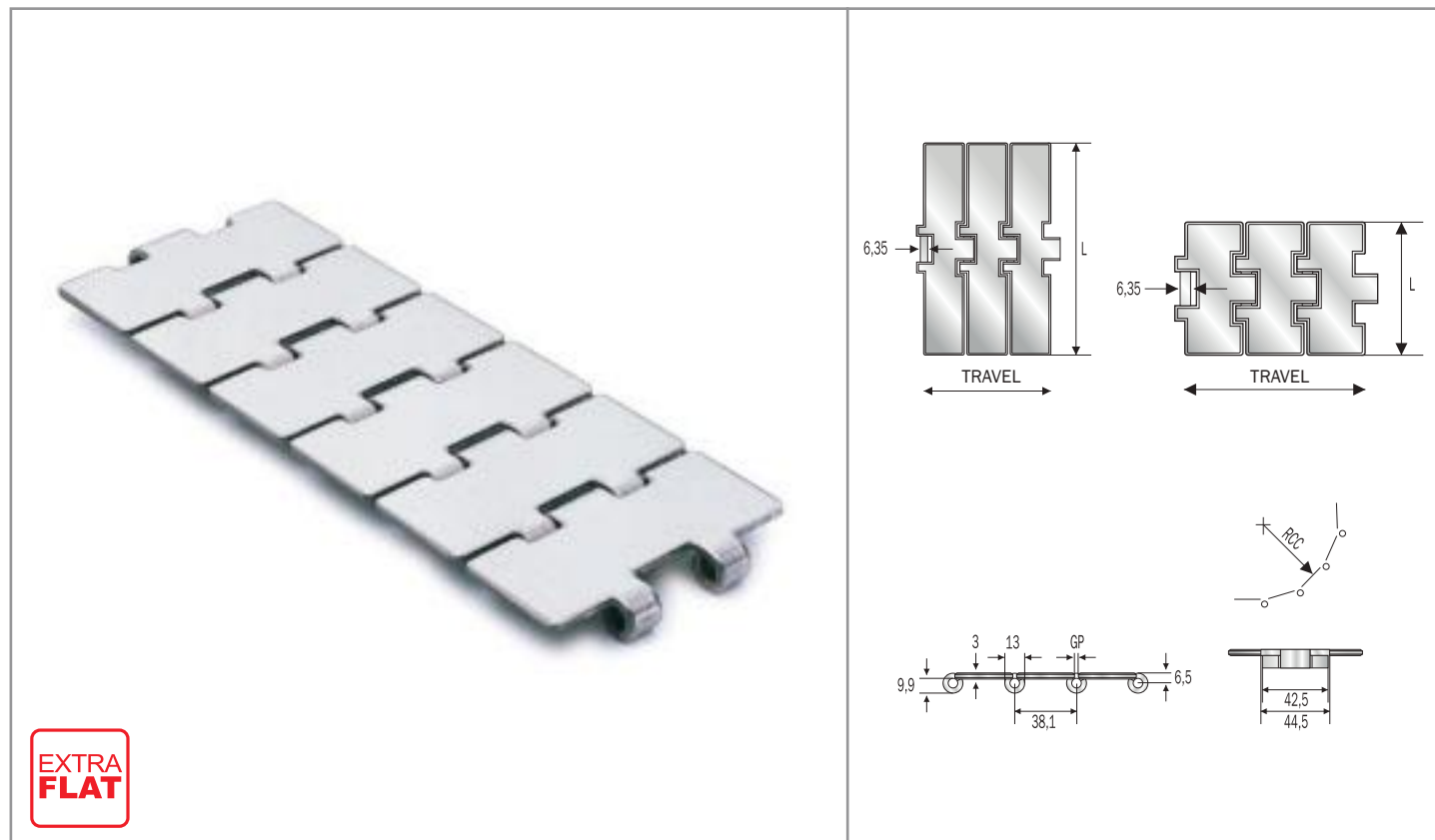

**EXTRA
FLAT**

SUPER - HARD INOX HB PINS UPON REQUEST



- Special, chrome-nickel, stainless steel slats, work hardened for high resistance, with shiny surface having a roughness of $Ra \leq 0,3$ micron.
- AISI 431 stainless steel pins, magnetic and work hardened for high resistance.



p.142
p.210
p.215



p.230
p.232

PRODUCT CODE	INTERNAL CODE	CHARACTERISTICS							
		Slat width (mm/ ")	Hardness (HRC)	GP (mm)	Flatness (max) mm	Polished hinges	Working Load N (max)	RCC (mm)	Weight kg/m
SSHR 812 K213*	S.7.00.013	54.1 -	30	2.8	0.18	no	6000	75	2.10
SSHR 812 K250	S.7.00.020	63.5 2 ^{1/2}	30	2.8	0.18	no	6000	75	2.20
SSHR 812 K325	S.7.00.040	82.5 3 ^{1/4}	30	2.8	0.18	no	6000	75	2.60
SSHR 812 K335	S.7.00.050	85.0 -	30	2.8	0.18	no	6000	75	2.68
SSHR 812 K500*	S.7.00.090	127.0 5	30	2.8	0.18	no	6000	75	3.50
	REDUCED PLATE GAP (1.6)								
SSH 812 K225	S.7.00.015	57.1 2 ^{1/4}	30	1.6	0.15	no	6000	150	2.18
SSH 812 K250	S.7.00.021	63.5 2 ^{1/2}	30	1.6	0.15	no	6000	150	2.25
SSH 812 K263	S.7.00.025	66.7 2 ^{5/8}	30	1.6	0.15	no	6000	150	2.33
SSH 812 K275	S.7.00.200	69.9 2 ^{3/4}	30	1.6	0.15	no	6000	150	2.35
SSH 812 K300	S.7.00.031	76.2 3	30	1.6	0.15	no	6000	150	2.50
SSH 812 K325	S.7.00.041	82.5 3 ^{1/4}	30	1.6	0.15	no	6000	150	2.65
SSH 812 K330	S.7.00.042	83.8 3 ^{19/64}	30	1.6	0.15	no	6000	150	2.70
SSH 812 K350	S.7.00.061	88.9 3 ^{1/2}	30	1.6	0.15	no	6000	150	2.75
SSH 812 K400	S.7.00.070	101.6 4	30	1.6	0.15	no	6000	150	3.00
SSH 812 K450	S.7.00.080	114.3 4 ^{1/2}	30	1.6	0.20	no	6000	150	3.30
SSH 812 K600	S.7.00.100	152.4 6	30	1.6	0.30	no	6000	150	4.20
SSH 812 K750	S.7.00.110	190.5 7 ^{1/2}	30	1.6	0.30	no	6000	150	5.10

* Size produced only upon request - delivery conditions and terms to be agreed. Standard shipping lengths: 80 pitches = 10 feet = 3,048 metres.

SUPERSPEED - HQ INOX

XHB PINS
UPON REQUEST



- Special, new stainless steel, chrome-nickel (W.1.4589) slats, work hardened for high resistance with very little roughness, **Ra ≤ 0.18 micron**.
 - Special martensitic stainless steel **pins HB series**, magnetic and heat-treated for high resistance.
- The chain is produced with a special profile: thanks to its perfect levelness and shiny surface, it is particularly suitable for pressureless combiners/ inliners and for high speed systems.



p.142
p.210
p.215



p.230
p.232

PRODUCT CODE	INTERNAL CODE	CHARACTERISTICS								
	REDUCED PLATE GAP (1.6)	Slat width (mm/ ")		Hardness (HRC)	GP (mm)	Flatness (max) mm	Polished hinges	Working Load N (max)	RCC (mm)	Weight kg/m
SSX 812 K325	DX.7.00.041	82.5	3 ^{1/4}	30	1.6	0.08	yes	6000	150	2.60
SSX 812 K330	DX.7.00.042	83.8	3 ^{19/64}	30	1.6	0.08	yes	6000	150	2.70

Standard shipping lengths: 80 pitches = 10 feet = 3,048 metres.

WEAR PROOF - HQ INOX

XHB PINS
UPON REQUEST



- Special, new stainless steel, chrome-nickel (W.1.4589) slats, work hardened for high resistance with very little surface roughness, **Ra ≤ 0.2 micron**.
- Special martensitic stainless steel **pins HB series**, magnetic and heat-treated for high resistance.



p.142
p.210
p.215



p.230
p.232

PRODUCT CODE	INTERNAL CODE	CHARACTERISTICS								
	REDUCED PLATE GAP (1.6)	Slat width (mm/ ")		Hardness (HRC)	GP (mm)	Flatness (max) mm	Polished hinges	Working Load N (max)	RCC (mm)	Weight kg/m
SSHQ 812 K250	D.7.00.021	63.5	2 ^{1/2}	30	1.6	0.08	yes	6000	150	2.25
SSHQ 812 K325	D.7.00.041	82.5	3 ^{1/4}	30	1.6	0.08	yes	6000	150	2.65
SSHQ 812 K330	D.7.00.042	83.8	3 ^{19/64}	30	1.6	0.08	yes	6000	150	2.75
SSHQ 812 K350	D.7.00.061	88,9	3 ^{1/2}	30	1.6	0.08	yes	6000	150	2.75
SSHQ 812 K450	D.7.00.080	114.3	4 ^{1/2}	30	1.6	0.20	yes	6000	150	3.30
SSHQ 812 K750	D.7.00.110	190.5	7 ^{1/2}	30	1.6	0.30	yes	6000	150	5.10

Standard shipping lengths: 80 pitches = 10 feet = 3,048 metres.

STANDARD - INOX

HB PINS
UPON REQUEST

- Ferritic, AISI 430 stainless steel slats, work hardened, with shiny surface having low roughness.
- AISI 431 stainless steel pins, magnetic and work hardened for high resistance.



p.142
p.210
p.215



p.230
p.232

PRODUCT CODE	INTERNAL CODE	CHARACTERISTICS								
	REDUCED PLATE GAP (1.6)	Slat width (mm/ ")		Hardness (HRC)	GP (mm)	Flatness (max) mm	Polished hinges	Working Load N (max)	RCC (mm)	Weight kg/m
SSR 812 K213*	7.00.013	54.1	-	20	2.8	0.18	no	5400	75	2.10
SSR 812 K250	7.00.020	63.5	2 ^{1/2}	20	2.8	0.18	no	5400	75	2.20
SSR 812 K325	7.00.040	82.5	3 ^{1/4}	20	2.8	0.18	no	5400	75	2.60
SSR 812 K335	7.00.050	85.0	-	20	2.8	0.18	no	5400	75	2.68
SS 812 K225	7.00.015	57.1	2 ^{1/4}	20	1.6	0.18	no	5400	150	2.18
SS 812 K250	7.00.021	63.5	2 ^{1/2}	20	1.6	0.18	no	5400	150	2.25
SS 812 K263	7.00.025	66.7	2 ^{5/8}	20	1.6	0.18	no	5400	150	2.33
SS 812 K275	7.00.200	69.9	2 ^{3/4}	20	1.6	0.18	no	5400	150	2.35
SS 812 K300	7.00.031	76.2	3	20	1.6	0.18	no	5400	150	2.50
SS 812 K325	7.00.041	82.5	3 ^{1/4}	20	1.6	0.18	no	5400	150	2.65
SS 812 K330	7.00.042	83.8	3 ^{19/64}	20	1.6	0.18	no	5400	150	2.70
SS 812 K350	7.00.061	88.9	3 ^{1/2}	20	1.6	0.18	no	5400	150	2.75
SS 812 K400	7.00.070	101.6	4	20	1.6	0.18	no	5400	150	3.00
SS 812 K450	7.00.080	114.3	4 ^{1/2}	20	1.6	0.20	no	5400	150	3.30
SS 812 K600	7.00.100	152.4	6	20	1.6	0.30	no	5400	150	4.20
SS 812 K750	7.00.110	190.5	7 ^{1/2}	20	1.6	0.30	no	5400	150	5.10

* Size produced only upon request - delivery conditions and terms to be agreed. Standard shipping lengths: 80 pitches = 10 feet = 3,048 metres.

316 - INOX 316

- Chrome-nickel, austenitic AISI 316L stainless steel slats (18% Chrome - 14% Nickel - 3% Molybdenum).
- Austenitic AISI 316 stainless steel pins.

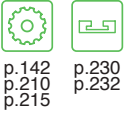

p.142 p.230
p.210 p.232
p.215

PRODUCT CODE		INTERNAL CODE		CHARACTERISTICS						
	REDUCED PLATE GAP (1.6)	Slat width (mm/ ")		Hardness (HRC)	GP (mm)	Flatness (max) mm	Polished hinges	Working Load N (max)	RCC (mm)	Weight kg/m
SSAA 815 K325*	7.25.041	82.5	3 ^{1/4}	-	1.6	0.18	no	5100	150	2.65
SSAA 815 K450*	7.25.080	114.3	4 ^{1/2}	-	1.6	0.20	no	5100	150	3.30
SSAA 815 K600*	7.25.100	152.4	6	-	1.6	0.30	no	5100	150	4.20
SSAA 815 K750*	7.25.110	190.5	7 ^{1/2}	-	1.6	0.30	no	5100	150	5.10

* Size produced only upon request - delivery conditions and terms to be agreed. Standard shipping lengths: 80 pitches = 10 feet = 3,048 metres.

STELLA D - INOX 18/8

- Chrome-nickel, austenitic AISI 304 stainless steel slats (18% Chrome - 8% Nickel), work hardened for HR - shiny - with a roughness of **Ra < 0.5 micron**.
- Austenitic stainless steel pins (18% Chrome - 8% Nickel), work hardened for high resistance.

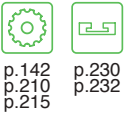

p.142 p.230
p.210 p.232
p.215

PRODUCT CODE		INTERNAL CODE		CHARACTERISTICS						
	REDUCED PLATE GAP (1.6)	Slat width (mm/ ")		Hardness (HRC)	GP (mm)	Flatness (max) mm	Polished hinges	Working Load N (max)	RCC (mm)	Weight kg/m
SSAR 815 K213*	7.10.013	54.1	-	26	2.8	0.18	no	5500	75	2.10
SSAR 815 K250	7.10.020	63.5	2 ^{1/2}	26	2.8	0.18	no	5500	75	2.20
SSAR 815 K325	7.10.040	82.5	3 ^{1/4}	26	2.8	0.18	no	5500	75	2.60
SSAR 815 K335*	7.10.050	85.0	-	26	2.8	0.18	no	5500	75	2.68
SSAR 815 K500	7.10.090	127.0	5	26	2.8	0.18	no	5500	75	3.50
SSA 815 K225	7.10.015	57.1	2 ^{1/4}	26	1.6	0.18	no	5500	150	2.18
SSA 815 K250	7.10.021	63.5	2 ^{1/2}	26	1.6	0.18	no	5500	150	2.25
SSA 815 K263	7.10.025	66.7	2 ^{5/8}	26	1.6	0.18	no	5500	150	2.33
SSA 815 K275	7.10.200	69.9	2 ^{3/4}	26	1.6	0.18	no	5500	150	2.35
SSA 815 K300	7.10.031	76.2	3	26	1.6	0.18	no	5500	150	2.50
SSA 815 K325	7.10.041	82.5	3 ^{1/4}	26	1.6	0.18	no	5500	150	2.65
SSA 815 K350	7.10.061	88.9	3 ^{1/2}	26	1.6	0.18	no	5500	150	2.75
SSA 815 K400	7.10.070	101.6	4	26	1.6	0.18	no	5500	150	3.00
SSA 815 K450	7.10.080	114.3	4 ^{1/2}	26	1.6	0.20	no	5500	150	3.30
SSA 815 K600	7.10.100	152.4	6	26	1.6	0.30	no	5500	150	4.20
SSA 815 K750	7.10.110	190.5	7 ^{1/2}	26	1.6	0.30	no	5500	150	5.10

* Size produced only upon request - delivery conditions and terms to be agreed. Standard shipping lengths: 80 pitches = 10 feet = 3,048 metres.

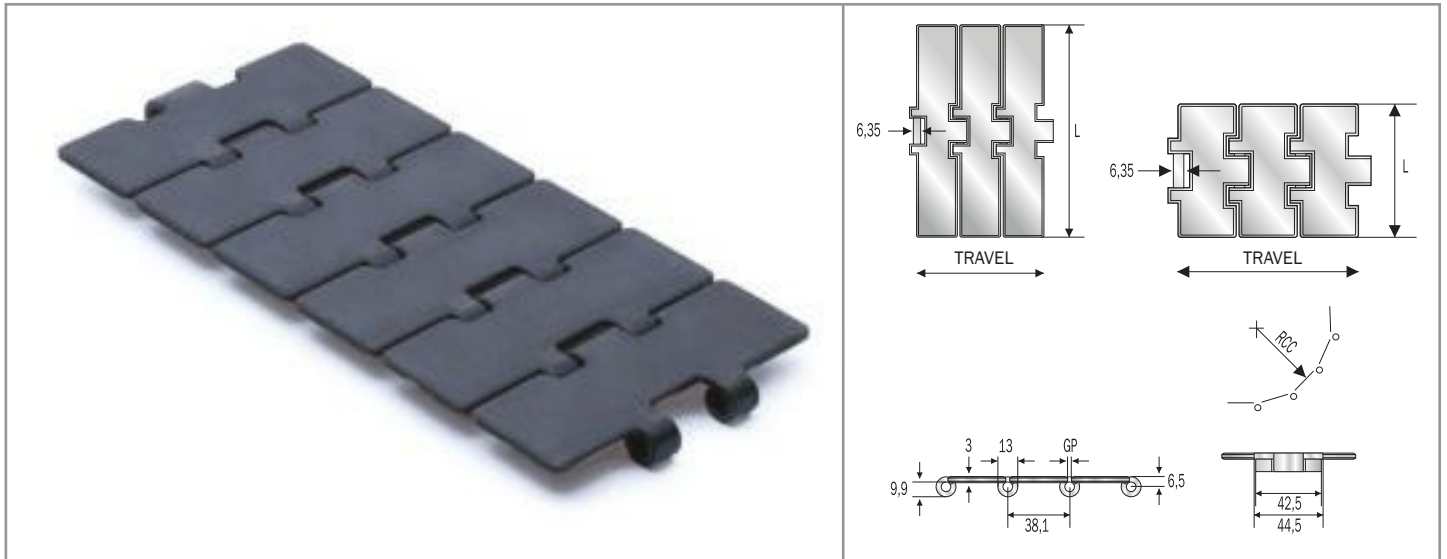

ACCATE C - CARBON STEEL

• Case-hardened carbon steel slats and pins.

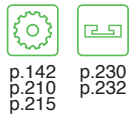

PRODUCT CODE	INTERNAL CODE	CHARACTERISTICS								
		Slat width (mm/ ")		Hardness (HRC) Surf Core	GP (mm)	Flatness (max) mm	Polished hinges	Working Load N (max)	RCC (mm)	Weight kg/m
SCR 815 K325*	C.7.90.040	82.5	3 1/4	55/40	2.8	0.40	no	11500	75	2.10
SC 815 K325*	C.7.90.041	82.5	3 1/4	55/40	1.6	0.40	no	11500	150	2.65
SC 815 K350*	C.7.90.061	88.9	3 1/2	55/40	1.6	0.40	no	11500	150	2.75
SC 815 K450*	C.7.90.080	114.3	4 1/2	55/40	1.6	0.50	no	11500	150	3.30

* Size produced only upon request - delivery conditions and terms to be agreed. Standard shipping lengths: 80 pitches = 10 feet = 3,048 metres.

ACCATE - CARBON STEEL

• Heat-treated carbon steel slats.
• Case-hardened carbon steel pins.

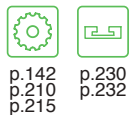

PRODUCT CODE	INTERNAL CODE	CHARACTERISTICS								
		Slat width (mm/ ")		Hardness (HRC) Surf Core	GP (mm)	Flatness (max) mm	Polished hinges	Working Load N (max)	RCC (mm)	Weight kg/m
SR 815 K250	7.90.020	63.5	2 1/2	43	2.8	0.40	no	12000	75	2.20
SR 815 K325	7.90.040	82.5	3 1/4	43	2.8	0.40	no	12000	75	2.60
SR 815 K500	7.90.090	127.0	5	43	2.8	0.40	no	12000	75	3.50
S 815 K225	7.90.015	57.1	2 1/4	43	1.6	0.40	no	12000	150	2.18
S 815 K250	7.90.021	63.5	2 1/2	43	1.6	0.40	no	12000	150	2.25
S 815 K263*	7.90.025	66.7	2 5/8	43	1.6	0.40	no	12000	150	2.33
S 815 K300	7.90.031	76.2	3	43	1.6	0.40	no	12000	150	2.35
S 815 K325	7.90.041	82.5	3 1/4	43	1.6	0.40	no	12000	150	2.50
S 815 K350	7.90.061	88.9	3 1/2	43	1.6	0.40	no	12000	150	2.75
S 815 K400	7.90.070	101.6	4	43	1.6	0.50	no	12000	150	2.65
S 815 K450	7.90.080	114.3	4 1/2	43	1.6	0.60	no	12000	150	3.00
S 815 K473*	7.90.220	120.0	-	43	1.6	0.60	no	12000	150	3.30
S 815 K600	7.90.100	152.4	6	43	1.6	0.80	no	12000	150	4.20
S 815 K750	7.90.110	190.5	7 1/2	43	1.6	0.90	no	12000	150	5.10

* Size produced only upon request - delivery conditions and terms to be agreed. Standard shipping lengths: 80 pitches = 10 feet = 3,048 metres.

mignon straight running chains

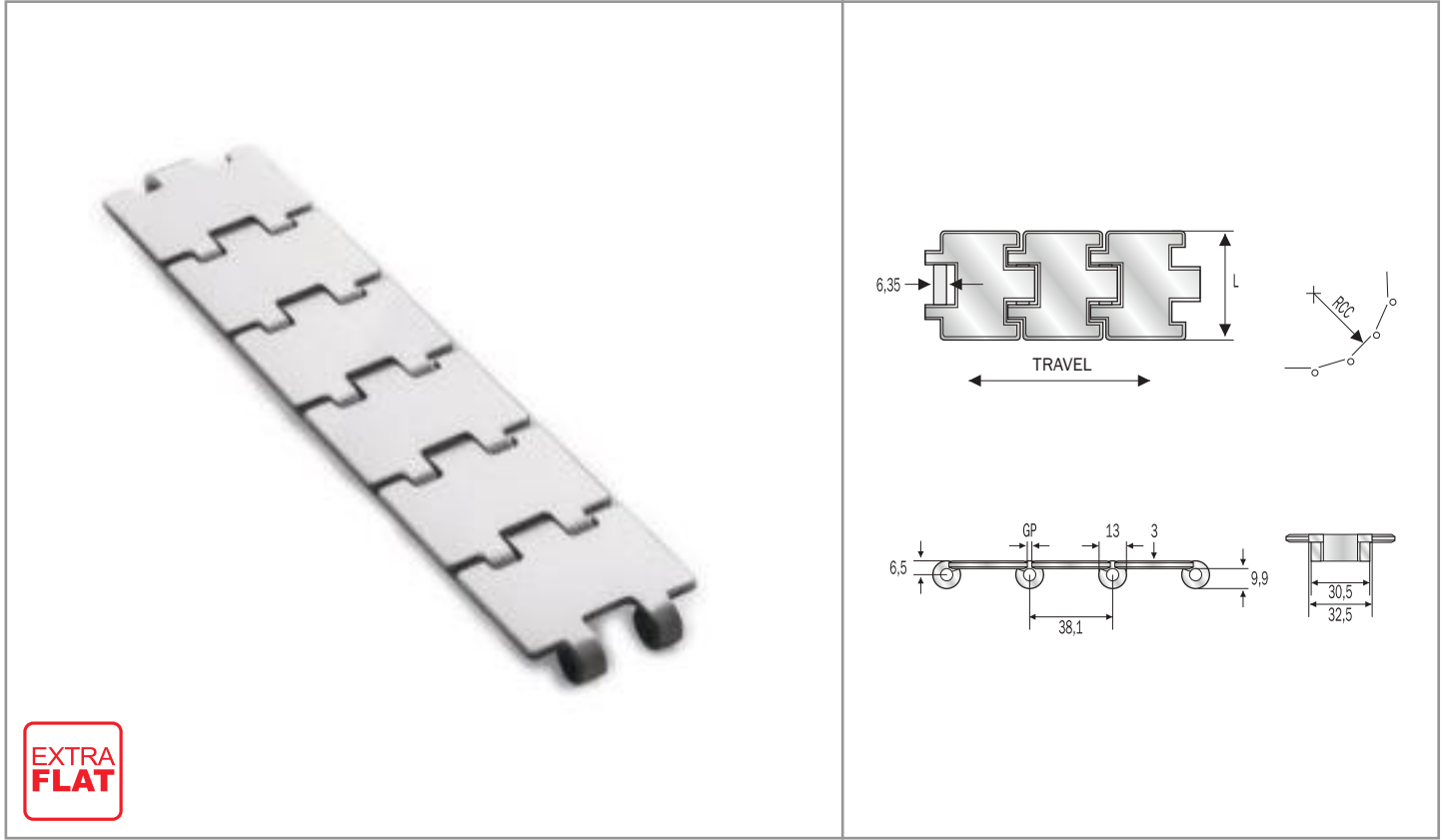

SINGLE HINGE



**EXTRA
FLAT**

STANDARD - INOX

- Ferritic, AISI 430 stainless steel slats, work hardened, with shiny surface having low roughness.
- AISI 431 stainless steel pins, magnetic and work hardened for high resistance.



 
p.150 p.232
p.215

PRODUCT CODE	INTERNAL CODE	CHARACTERISTICS							
		Slat width (mm/ ")	Hardness (HRC)	GP (mm)	Flatness (max) mm	Polished hinges	Working Load N (max)	RCC (mm)	Weight kg/m
SSR 812 K197	7.00.010	50.0 -	20	2.5	0.18	no	2500	90	1.60

Standard shipping lengths: 80 pitches = 10 feet = 3,048 metres.

STELLA D - INOX 18/8

- Chrome-nickel, austenitic AISI 304 stainless steel slats (18% Chrome - 8% Nickel), work hardened for HR - shiny - with a roughness of **Ra < 0.5 micron**.
- Austenitic stainless steel pins (18% Chrome - 8% Nickel), work hardened for high resistance.

 
p.150 p.232
p.215

PRODUCT CODE	INTERNAL CODE	CHARACTERISTICS							
		Slat width (mm/ ")	Hardness (HRC)	GP (mm)	Flatness (max) mm	Polished hinges	Working Load N (max)	RCC (mm)	Weight kg/m
SSAR 815 K197	7.10.010	50.0 -	26	2.5	0.18	no	2800	90	1.60

Standard shipping lengths: 80 pitches = 10 feet = 3,048 metres.

mignon straight running chains

SINGLE HINGE

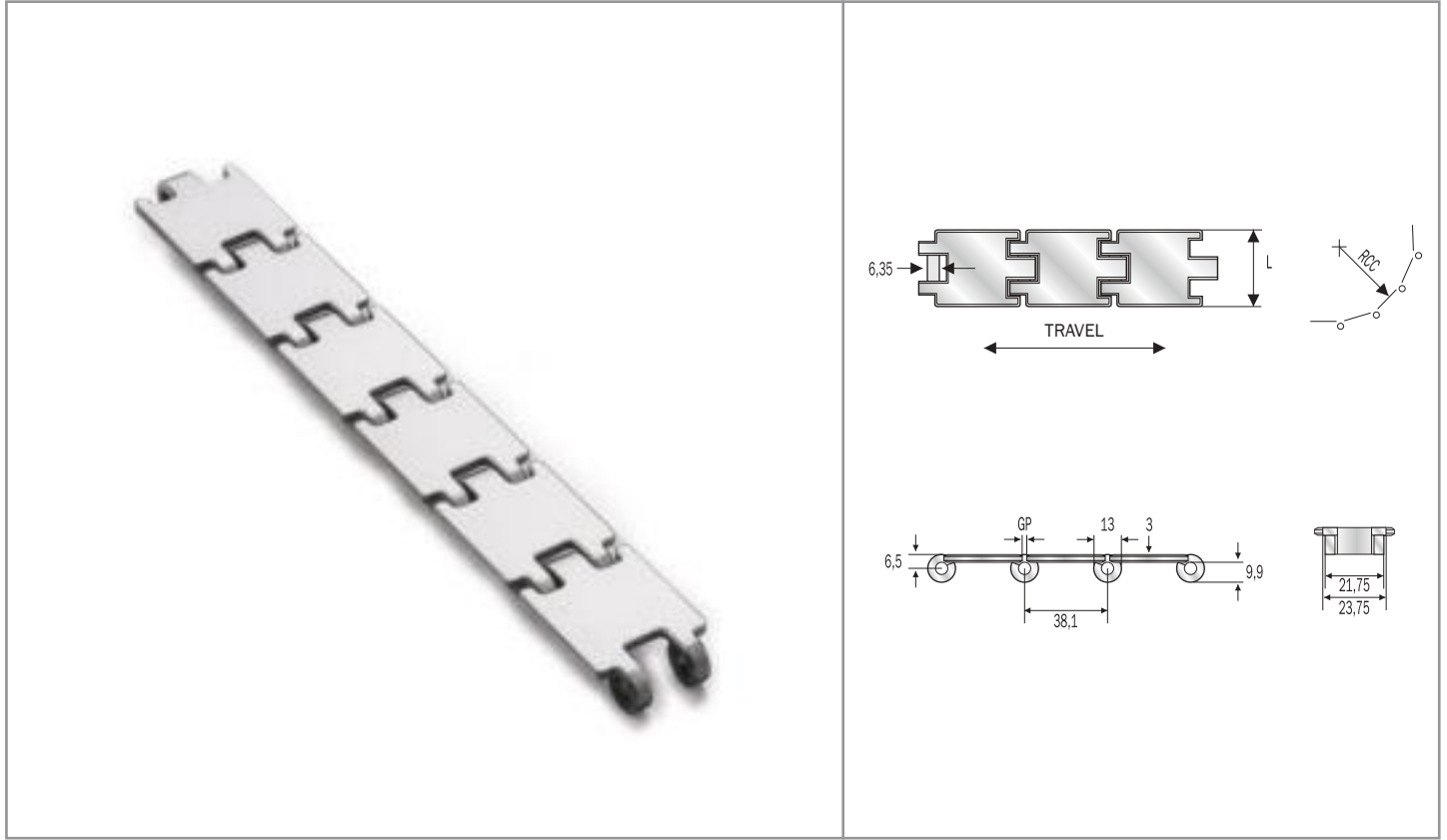

SUPER - HARD INOX

HB OR XHB PINS
UPON REQUEST



- Special, chrome-nickel, stainless steel slats, work hardened for high resistance, with shiny surface having a roughness of $Ra \leq 0.3$ micron.
- AISI 431 stainless steel pins, magnetic and work hardened for high resistance.



p.150
p.215



p.232

PRODUCT CODE		INTERNAL CODE		CHARACTERISTICS						
		Slat width (mm/ ")		Hardness (HRC)	GP (mm)	Flatness (max) mm	Polished hinges	Working Load N (max)	RCC (mm)	Weight kg/m
SSHR 812 K125	8.25.280	31.8	1 1/4	30	2.8	0.18	no	2500	75	1.10
SSHR 812 K175	8.25.300	44.5	1 3/4	30	2.8	0.18	no	2500	75	1.30

Standard shipping lengths: 80 pitches = 10 feet = 3,048 metres.

ACCATE - CARBON STEEL

- Heat-treated carbon steel slats.
- Case-hardened carbon steel pins.



p.150
p.215



p.232

PRODUCT CODE		INTERNAL CODE		CHARACTERISTICS						
		Slat width (mm/ ")		Hardness (HRC)	GP (mm)	Flatness (max) mm	Polished hinges	Working Load N (max)	RCC (mm)	Weight kg/m
SR 815 K125	8.95.280	31.8	1 1/4	43	2.8	0.40	no	3300	75	1.10
SR 815 K175	8.95.300	44.5	1 3/4	43	2.8	0.40	no	3300	75	1.30

Standard shipping lengths: 80 pitches = 10 feet = 3,048 metres.

straight running chains

SINGLE HINGE 1 INCH



**EXTRA
FLAT**

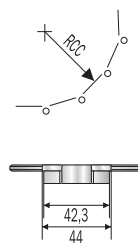
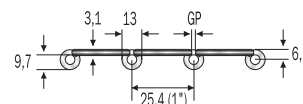
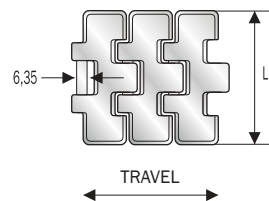

SUPER - HARD INOX



- Special, chrome-nickel, stainless steel slats, work hardened for high resistance, with shiny surface having a roughness of **Ra ≤ 0,3 micron**.
- AISI 431 stainless steel pins, magnetic and work hardened for high resistance.

p.148 p.232

PRODUCT CODE	INTERNAL CODE	CHARACTERISTICS							
	REDUCED PLATE GAP (1.6)	Slat width (mm/ ")	Hardness (HRC)	GP (mm)	Flatness (max) mm	Polished hinges	Working Load N (max)	RCC (mm)	Weight kg/m
SSH 512 K197*	S.9.00.010	50.0	30	1.6	0.30	no	5200	100	2.20
SSH 512 K217	S.9.00.017	55.0	30	1.6	0.30	no	5200	100	2.29
SSH 512 K236	S.9.00.036	60.0	30	1.6	0.30	no	5200	100	2.41
SSH 512 K250	S.9.00.020	63.5	30	1.6	0.30	no	5200	100	2.49
SSH 512 K283	S.9.00.283	72.0	30	1.6	0.30	no	5200	100	2.65
SSH 512 K325	S.9.00.040	82.5	30	1.6	0.30	no	5200	100	2.86
SSH 512 K350	S.9.00.060	88.9	30	1.6	0.30	no	5200	100	3.01
SSH 512 K400	S.9.00.070	101.6	30	1.6	0.30	no	5200	100	3.26

Standard shipping lengths: 120 pitches = 10 feet = 3,048 metres.

* Size produced only upon request - delivery conditions and terms to be agreed.

straight running chains

SINGLE REINFORCED HINGE

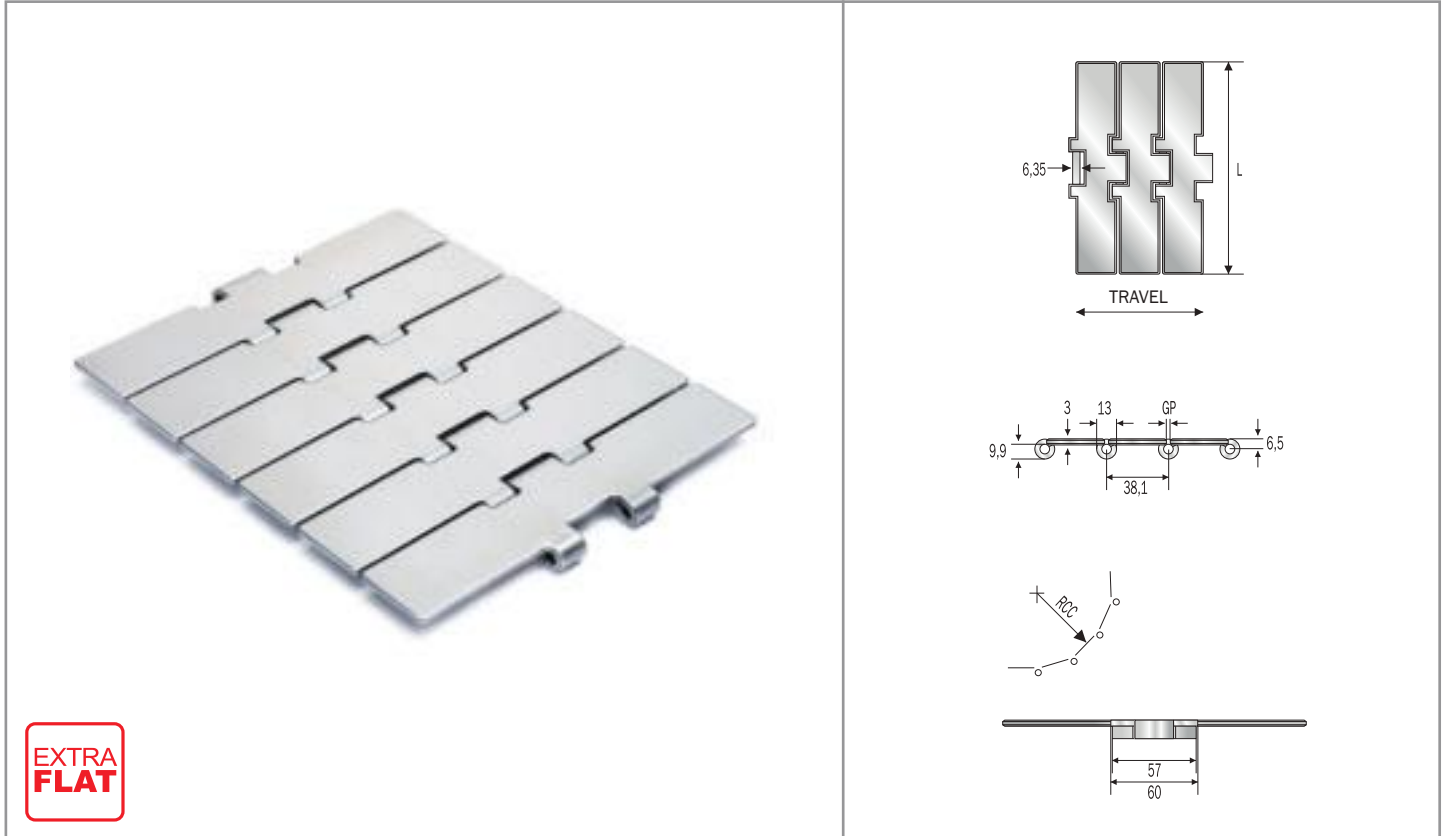

**EXTRA
FLAT**

SUPER - HARD INOX

HB PINS
UPON REQUEST



p.157

p.230
p.232

- Special, chrome-nickel, stainless steel slats, work hardened for high resistance, with shiny surface having a roughness of $Ra \leq 0.3$ micron.
- AISI 431 stainless steel pins, magnetic and work hardened for high resistance.

PRODUCT CODE	INTERNAL CODE	CHARACTERISTICS							
	REDUCED PLATE GAP (1.6)	Slat width (mm/ ")	Hardness (HRC)	GP (mm)	Flatness (max) mm	Polished hinges	Working Load N (max)	RCC (mm)	Weight kg/m
SSH 8127 K750	S.7.00.175	190.5 7 ^{1/2}	30	1.6	0.30	no	10400	150	5.10

Standard shipping lengths: 80 pitches = 10 feet = 3,048 metres.

WEAR PROOF - HQ INOX

XHB PINS
UPON REQUEST



p.157

p.230
p.232

- Special, new stainless steel, chrome-nickel (W. 1.4589) slats, work hardened for high resistance with very little surface roughness, $Ra \leq 0.2$ micron.
- Special martensitic stainless steel pins **HB series**, magnetic and heat-treated for high resistance.

PRODUCT CODE	INTERNAL CODE	CHARACTERISTICS							
	REDUCED PLATE GAP (1.6)	Slat width (mm/ ")	Hardness (HRC)	GP (mm)	Flatness (max) mm	Polished hinges	Working Load N (max)	RCC (mm)	Weight kg/m
SSHQ 8127 K750	D.7.00.175	190.5 7 ^{1/2}	30	1.6	0.30	no	10400	150	5.10

Standard shipping lengths: 80 pitches = 10 feet = 3,048 metres.

straight running chains

SINGLE REINFORCED HINGE WITH TABS

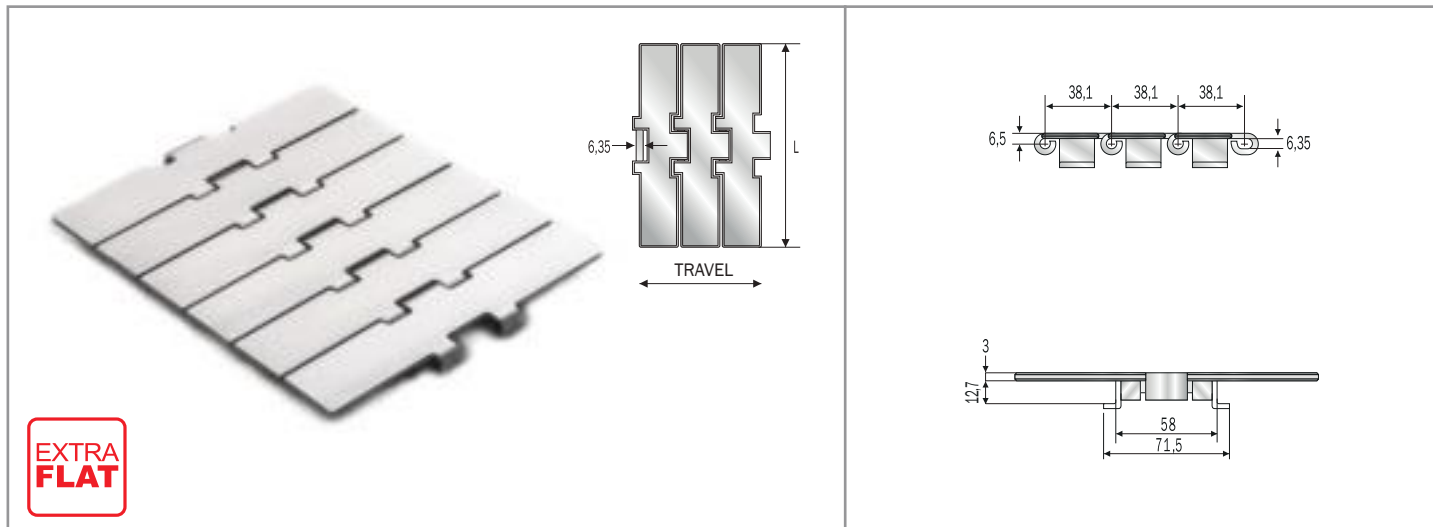

SUPER - HARD INOX

HB PINS
UPON REQUEST



- Special, chrome-nickel, stainless steel slats, work hardened for high resistance, with shiny surface having a roughness of $Ra \leq 0.3$ micron.
- AISI 431 stainless steel pins, magnetic and work hardened for high resistance.
- Chrome-nickel, austenitic stainless steel guide shoes (18% Chrome - 8% Nickel), work hardened for high resistance.



p.157



p.232

PRODUCT CODE		INTERNAL CODE		CHARACTERISTICS						
	REDUCED PLATE GAP (1.6)	Slat width (mm/ ")	Hardness (HRC)	GP (mm)	Flatness (max) mm	Polished hinges	Working Load N (max)	RCC (mm)	Weight kg/m	
SSH 8127 T K750	S.7.00.175TAB*	190.5 7 ^{1/2}	30	1.6	0.30	no	10400	150	5.90	

Standard shipping lengths: 80 pitches = 10 feet = 3,048 metres.

* Size produced only upon request - delivery conditions and terms to be agreed.

straight running chains

DOUBLE HINGE

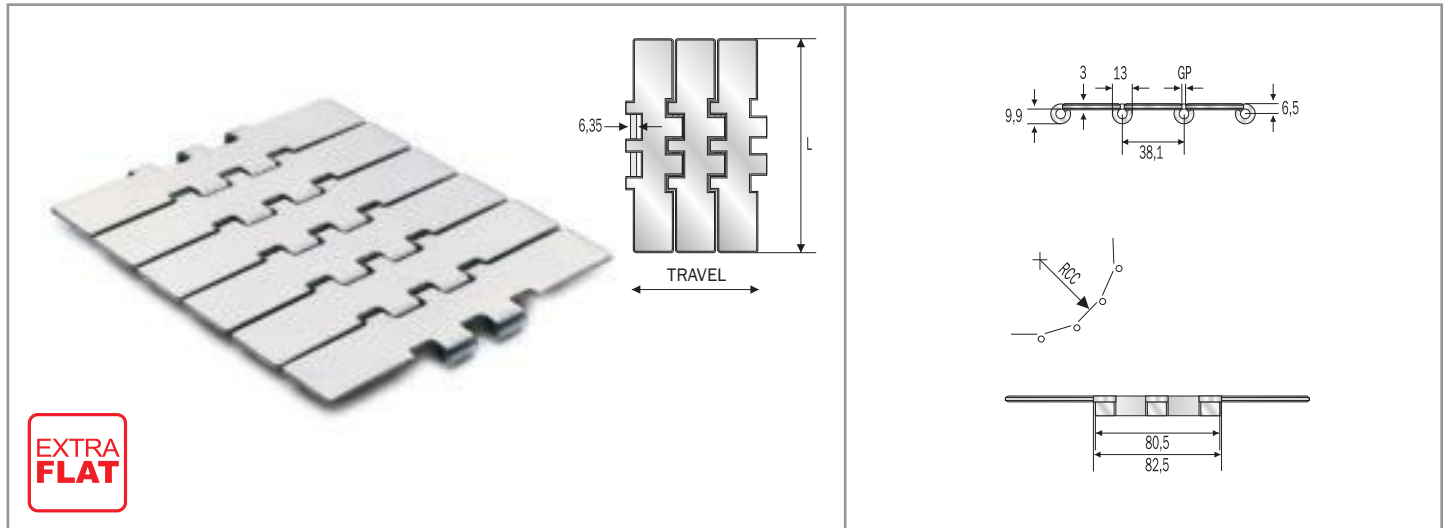

STANDARD - INOX

- Ferritic, AISI 430 stainless steel slats, work hardened, with shiny surface having low roughness.
- AISI 431 stainless steel pins, magnetic and work hardened for high resistance.



p.153
p.211

p.230
p.232

PRODUCT CODE	INTERNAL CODE	CHARACTERISTICS								
	REDUCED PLATE GAP (1.6)	Slat width (mm/ ")		Hardness (HRC)	GP (mm)	Flatness (max) mm	Polished hinges	Working Load N (max)	RCC (mm)	Weight kg/m
SS 802 K750	7.04.110	190.5	7 1/2	20	1.6	0.30	no	10300	150	5.80

Standard shipping lengths: 80 pitches = 10 feet = 3,048 metres.

SUPER - HARD INOX

HB PINS
UPON REQUEST



- Special, chrome-nickel, stainless steel slats, work hardened for high resistance, with shiny surface having a roughness of $Ra \leq 0.3$ micron.
- AISI 431 stainless steel pins, magnetic and work hardened for high resistance.



p.153
p.211

p.230
p.232

PRODUCT CODE	INTERNAL CODE	CHARACTERISTICS								
	REDUCED PLATE GAP (1.6)	Slat width (mm/ ")		Hardness (HRC)	GP (mm)	Flatness (max) mm	Polished hinges	Working Load N (max)	RCC (mm)	Weight kg/m
SSH 802 K450	S.7.04.080	114.3	4 1/2	30	1.6	0.30	no	15000	150	4.00
SSH 802 K500*	S.7.04.090	127.0	5	30	1.6	0.30	no	15000	150	4.45
SSH 802 K600	S.7.04.100	152.4	6	30	1.6	0.30	no	15000	150	4.95
SSH 802 K750	S.7.04.110	190.5	7 1/2	30	1.6	0.30	no	15000	150	5.80

Standard shipping lengths: 80 pitches = 10 feet = 3,048 metres.

* Size produced only upon request - delivery conditions and terms to be agreed.

STELLA D - INOX 18/8

- Chrome-nickel, austenitic AISI 304 stainless steel slats (18% Chrome - 8% Nickel), work hardened for HR - shiny - with a roughness of $Ra < 0.5$ micron.
- Austenitic stainless steel pins (18% Chrome - 8% Nickel), work hardened for high resistance.



p.153
p.211

p.230
p.232

PRODUCT CODE	INTERNAL CODE	CHARACTERISTICS								
	REDUCED PLATE GAP (1.6)	Slat width (mm/ ")		Hardness (HRC)	GP (mm)	Flatness (max) mm	Polished hinges	Working Load N (max)	RCC (mm)	Weight kg/m
SSA 805 K450	7.14.080	114.3	4 1/2	26	1.6	0.30	no	9600	150	4.00
SSA 805 K500*	7.14.090	127.0	5	26	1.6	0.30	no	9600	150	4.45
SSA 805 K600	7.14.100	152.4	6	26	1.6	0.30	no	9600	150	4.95
SSA 805 K750	7.14.110	190.5	7 1/2	26	1.6	0.30	no	9600	150	5.80

Standard shipping lengths: 80 pitches = 10 feet = 3,048 metres.

* Size produced only upon request - delivery conditions and terms to be agreed.

straight running chains

DOUBLE HINGE

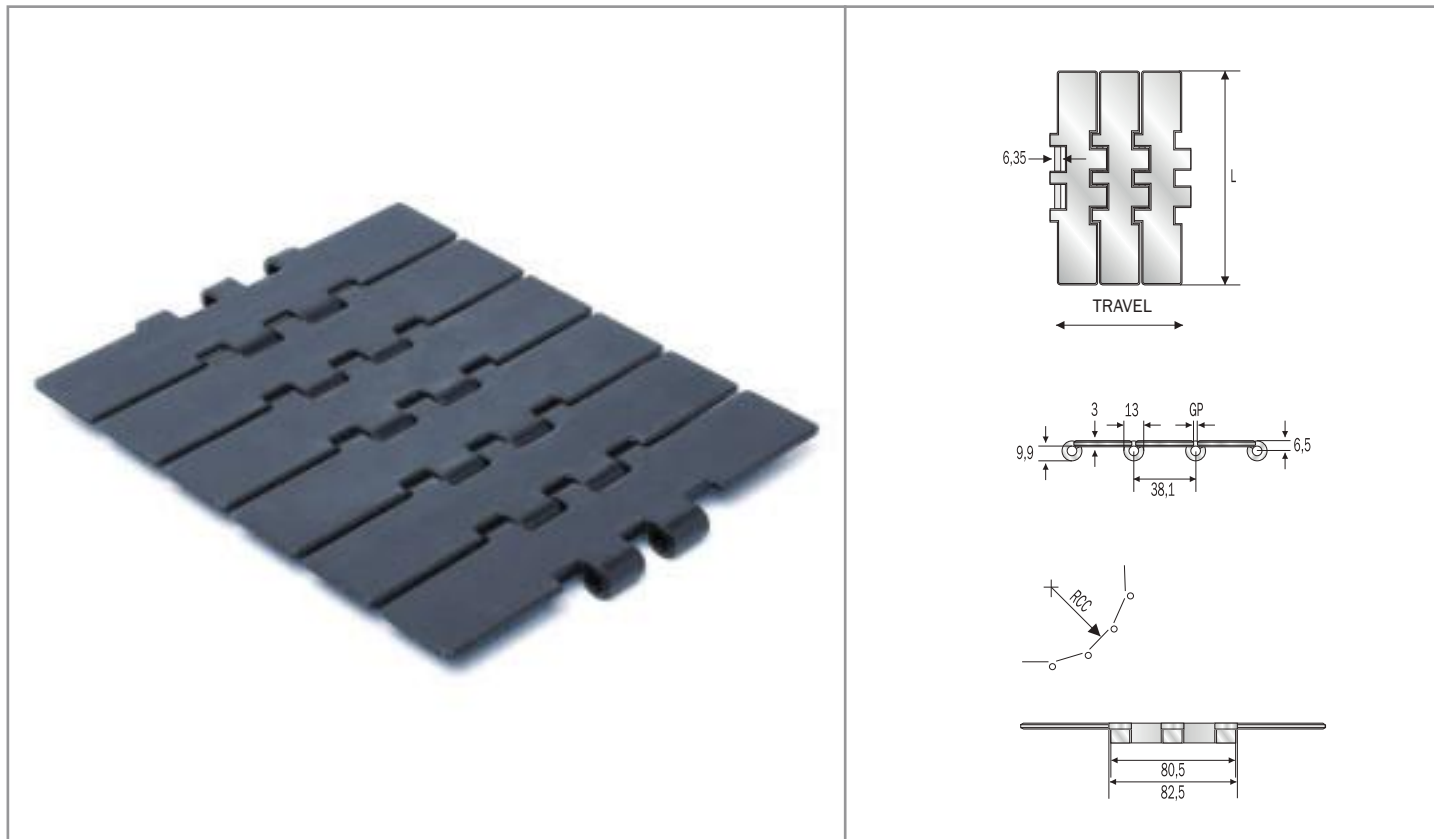

ACCATE - CARBON STEEL

- Heat-treated carbon steel slats.
- Case-hardened carbon steel pins.



PRODUCT CODE		INTERNAL CODE		CHARACTERISTICS						
		Slat width (mm/ ")		Hardness (HRC)	GP (mm)	Flatness (max) mm	Polished hinges	Working Load N (max)	RCC (mm)	Weight kg/m
SR 802 K750	7.94.111	190.5	7 ¹ / ₂	43	2.8	0.90	no	28000	75	5.70
S 802 K450	7.94.080	114.3	4 ¹ / ₂	43	1.6	0.90	no	28000	150	4.00
S 802 K500*	7.94.090	127.0	5	43	1.6	0.90	no	28000	150	4.45
S 802 K600	7.94.100	152.4	6	43	1.6	0.90	no	28000	150	4.95
S 802 K750	7.94.110	190.5	7 ¹ / ₂	43	1.6	0.90	no	28000	150	5.80

Standard shipping lengths: 80 pitches = 10 feet = 3,048 metres.

* Size produced only upon request - delivery conditions and terms to be agreed.

straight running chains

DOUBLE REINFORCED HINGE

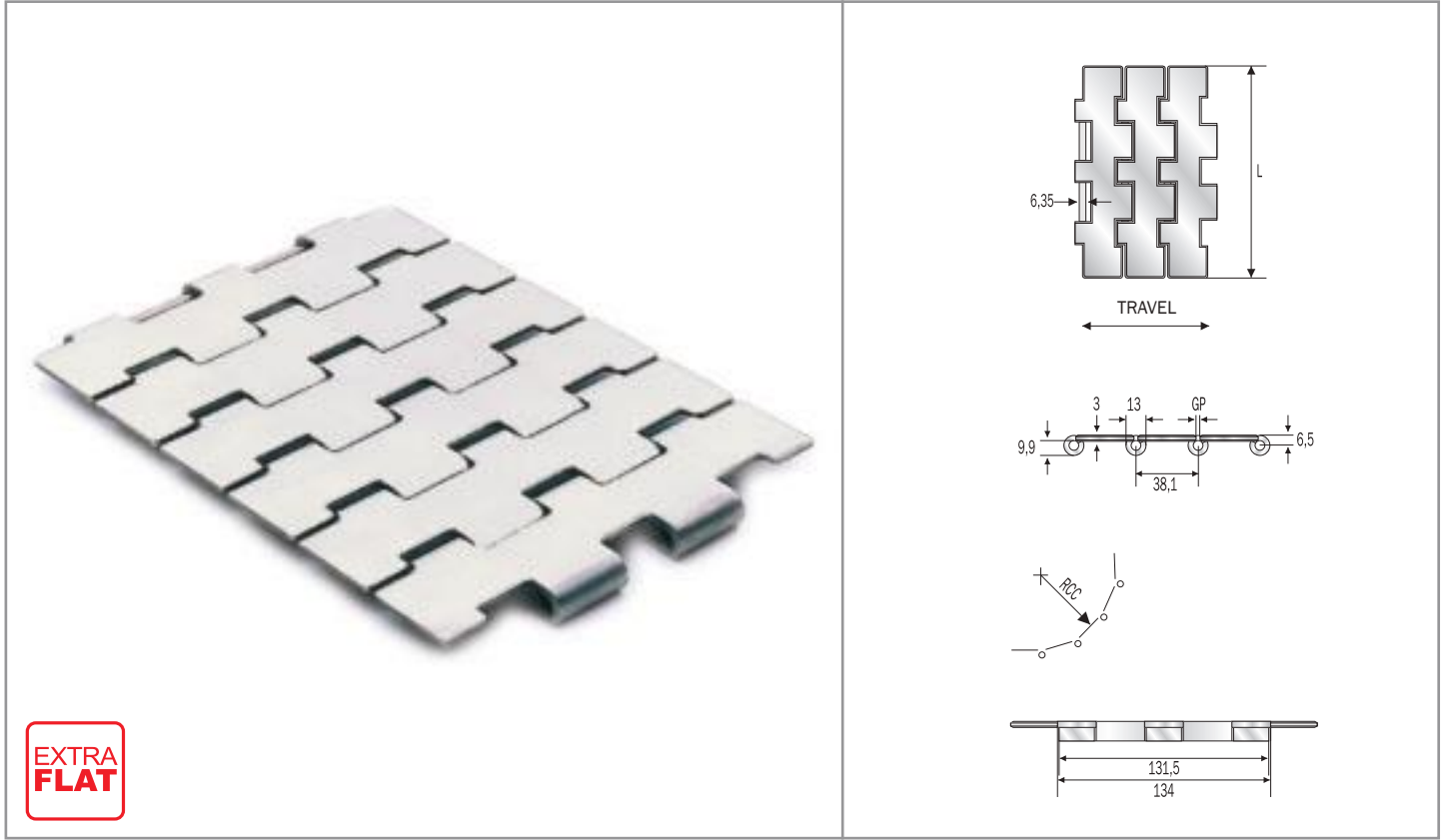

STELLA D - INOX 18/8

- Chrome-nickel, austenitic AISI 304 stainless steel slats (18% Chrome - 8% Nickel), work hardened for HR - shiny - with a roughness of **Ra < 0.5 micron**.
- Austenitic stainless steel pins (18% Chrome - 8% Nickel), work hardened for high resistance.



p.153
p.211

p.232

PRODUCT CODE		INTERNAL CODE		CHARACTERISTICS						
		Slat width (mm/ ")		Hardness (HRC)	GP (mm)	Flatness (max) mm	Polished hinges	Working Load N (max)	RCC (mm)	Weight kg/m
SSAR 804 K670	7.24.050	170.0	-	26	2.5	0.90	no	24000	90	6.30
SSAR 804 K750	7.24.060	190.5	7 1/2	26	2.5	0.90	no	24000	90	6.80

Standard shipping lengths: 80 pitches = 10 feet = 3,048 metres.

sideflexing hinged slat chains

SINGLE HINGE

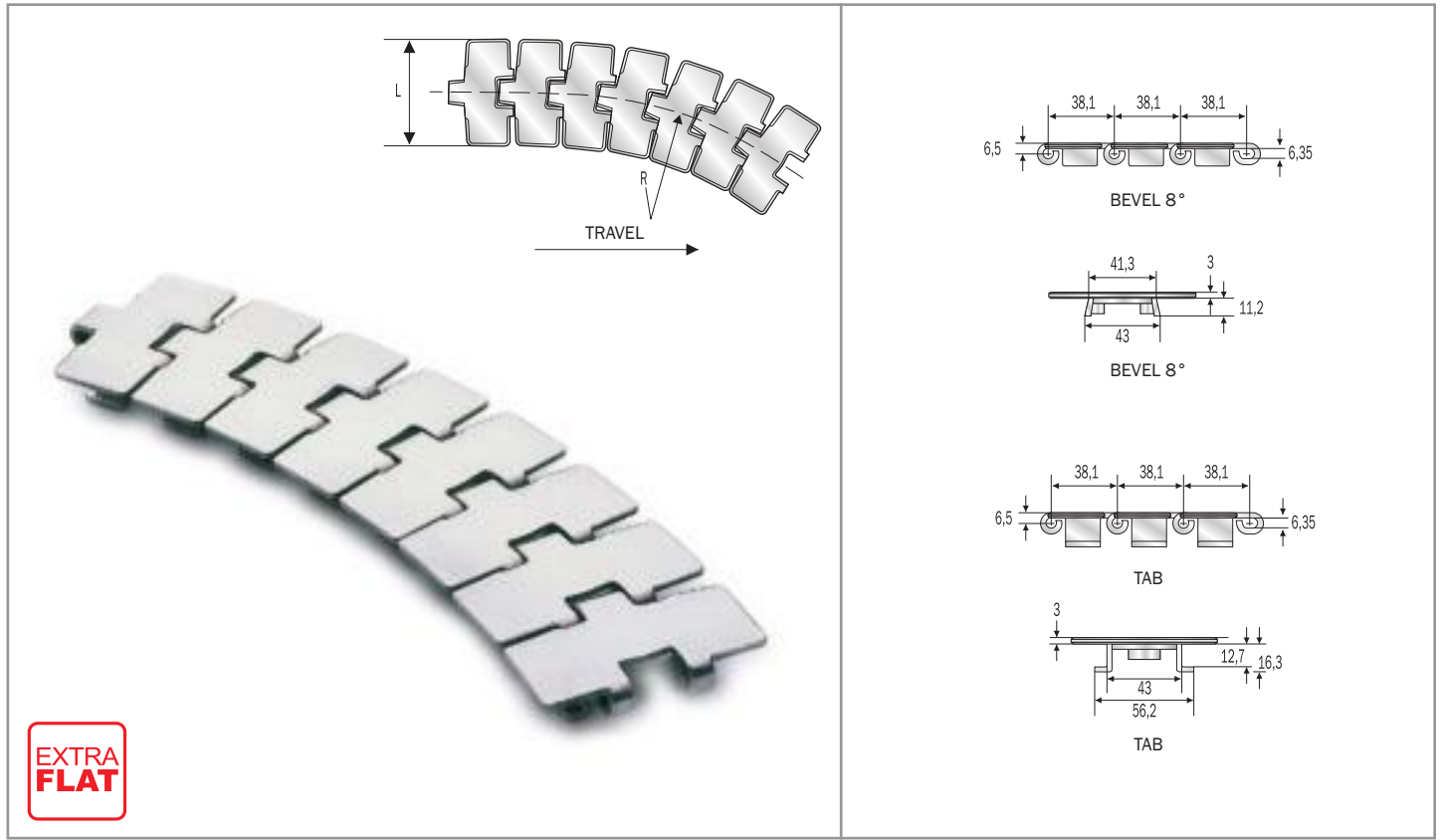

**EXTRA
FLAT**

FLEX RXMC - INOX

- Ferritic, AISI 430 stainless steel slats, work hardened, with shiny surface having low roughness.
- Chrome-nickel, austenitic stainless steel guide shoes (18% Chrome - 8% Nickel), work hardened for high resistance.
- AISI 431 stainless steel pins, magnetic and work hardened for high resistance.



p.161 p.218 p.228
p.211 p.220 p.229

PRODUCT CODE		INTERNAL CODE		CHARACTERISTICS					
		Slat width (mm/ ")		Min. sideflexing radius (mm)	Hardness (HRC)	Flatness (max) mm	Polished hinges	Working Load N (max)	Weight kg/m
BEVEL 8°									
SS 881 K325	8.23.040	82.5	3 ^{1/4}	457	20	0.18	no	5400	2.80
SS 881 K450	8.23.080	114.3	4 ^{1/2}	500	20	0.25	no	5400	3.40
SS 881 K750	8.23.110	190.5	7 ^{1/2}	500	20	0.40	no	5400	4.80
TAB									
SS 881 T K325	8.23.041	82.5	3 ^{1/4}	457	20	0.18	no	5400	3.10
SS 881 T K450	8.23.081	114.3	4 ^{1/2}	500	20	0.25	no	5400	3.60
SS 881 T K750	8.23.111	190.5	7 ^{1/2}	500	20	0.40	no	5400	5.05

Standard shipping lengths: 80 pitches = 10 feet = 3,048 metres.

FLEX RXMS - HARD INOX

HB PINS
UPON REQUEST



- Special, chrome-nickel, stainless steel slats, work hardened for high resistance, with shiny surface having a roughness of **Ra ≤ 0.3 micron**.
- Chrome-nickel, austenitic stainless steel guide shoes (18% Chrome - 8% Nickel), work hardened for high resistance.
- AISI 431 stainless steel pins, magnetic and work hardened for high resistance.

p.161
p.211

p.218
p.220

p.228
p.229

PRODUCT CODE	INTERNAL CODE	CHARACTERISTICS							
		Slat width (mm/ ")		Min. sideflexing radius (mm)	Hardness (HRC)	Flatness (max) mm	Polished hinges	Working Load N (max)	Weight kg/m
BEVEL 8°									
SSH 881 K325	S.8.23.040	82.5	3 ^{1/4}	457	30	0.18	no	6000	2.80
SSH 881 K450	S.8.23.080	114.3	4 ^{1/2}	500	30	0.25	no	6000	3.40
SSH 881 K600*	S.8.23.100	152.4	6	500	30	0.40	no	6000	4.10
SSH 881 K750	S.8.23.110	190.5	7 ^{1/2}	500	30	0.40	no	6000	4.80
TAB									
SSH 881 T K325	S.8.23.041	82.5	3 ^{1/4}	457	30	0.18	no	6000	2.95
SSH 881 T K450	S.8.23.081	114.3	4 ^{1/2}	500	30	0.25	no	6000	3.60
SSH 881 T K600*	S.8.23.101	152.4	6	500	30	0.40	no	6000	4.25
SSH 881 T K750	S.8.23.111	190.5	7 ^{1/2}	500	30	0.40	no	6000	5.05

Standard shipping lengths: 80 pitches = 10 feet = 3,048 metres.

* Size produced only upon request - delivery conditions and terms to be agreed.

FLEX RXM - INOX 18/8



- Chrome-nickel, austenitic AISI 304 stainless steel slats (18% Chrome - 8% Nickel), work hardened for HR - shiny with a roughness of **Ra < 0.5 micron**.
- Chrome-nickel, austenitic stainless steel guide shoes (18% Chrome - 8% Nickel), work hardened for high resistance.
- Austenitic stainless steel pins (18% Chrome - 8% Nickel), work hardened for high resistance.

p.161
p.211

p.218
p.220

p.228
p.229

PRODUCT CODE	INTERNAL CODE	CHARACTERISTICS							
		Slat width (mm/ ")		Min. sideflexing radius (mm)	Hardness (HRC)	Flatness (max) mm	Polished hinges	Working Load N (max)	Weight kg/m
BEVEL 8°									
SSA 881 K325	8.13.040	82.5	3 ^{1/4}	457	26	0.18	no	5500	2.90
SSA 881 K450	8.13.080	114.3	4 ^{1/2}	500	26	0.25	no	5500	3.60
SSA 881 K600*	8.13.100	152.4	6	500	26	0.40	no	5500	4.30
SSA 881 K750	8.13.110	190.5	7 ^{1/2}	500	26	0.40	no	5500	5.30
TAB									
SSA 881 T K325	8.13.041	82.5	3 ^{1/4}	457	26	0.18	no	5500	3.10
SSA 881 T K450	8.13.081	114.3	4 ^{1/2}	500	26	0.25	no	5500	3.80
SSA 881 T K600*	8.13.101	152.4	6	500	26	0.40	no	5500	4.45
SSA 881 T K750	8.13.111	190.5	7 ^{1/2}	500	26	0.40	no	5500	5.50

Standard shipping lengths: 80 pitches = 10 feet = 3,048 metres.

* Size produced only upon request - delivery conditions and terms to be agreed.

FLEX RXM - INOX 316



- Chrome-nickel, austenitic AISI 316L stainless steel slats (18% Chrome - 14% Nickel - 3% Molybdenum).
- Chrome-nickel, austenitic AISI 316L stainless steel guide shoes.
- Austenitic AISI 316 stainless steel pins.

p.161
p.211

p.218
p.220

p.228
p.229

PRODUCT CODE	INTERNAL CODE	CHARACTERISTICS							
		Slat width (mm/ ")		Min. sideflexing radius (mm)	Hardness (HRC)	Flatness (max) mm	Polished hinges	Working Load N (max)	Weight kg/m
SSAA 881 T K325*	8.33.041	82.5	3 ^{1/4}	457	-	0.18	no	4500	3.10
SSAA 881 T K450*	8.33.081	114.3	4 ^{1/2}	500	-	0.25	no	4500	3.80
SSAA 881 T K600*	8.33.101	152.4	6	500	-	0.40	no	4500	4.45
SSAA 881 T K750*	8.33.111	190.5	7 ^{1/2}	500	-	0.40	no	4500	5.50

Standard shipping lengths: 80 pitches = 10 feet = 3,048 metres.

* Size produced only upon request - delivery conditions and terms to be agreed.

sideflexing hinged slat chains

SINGLE HINGE

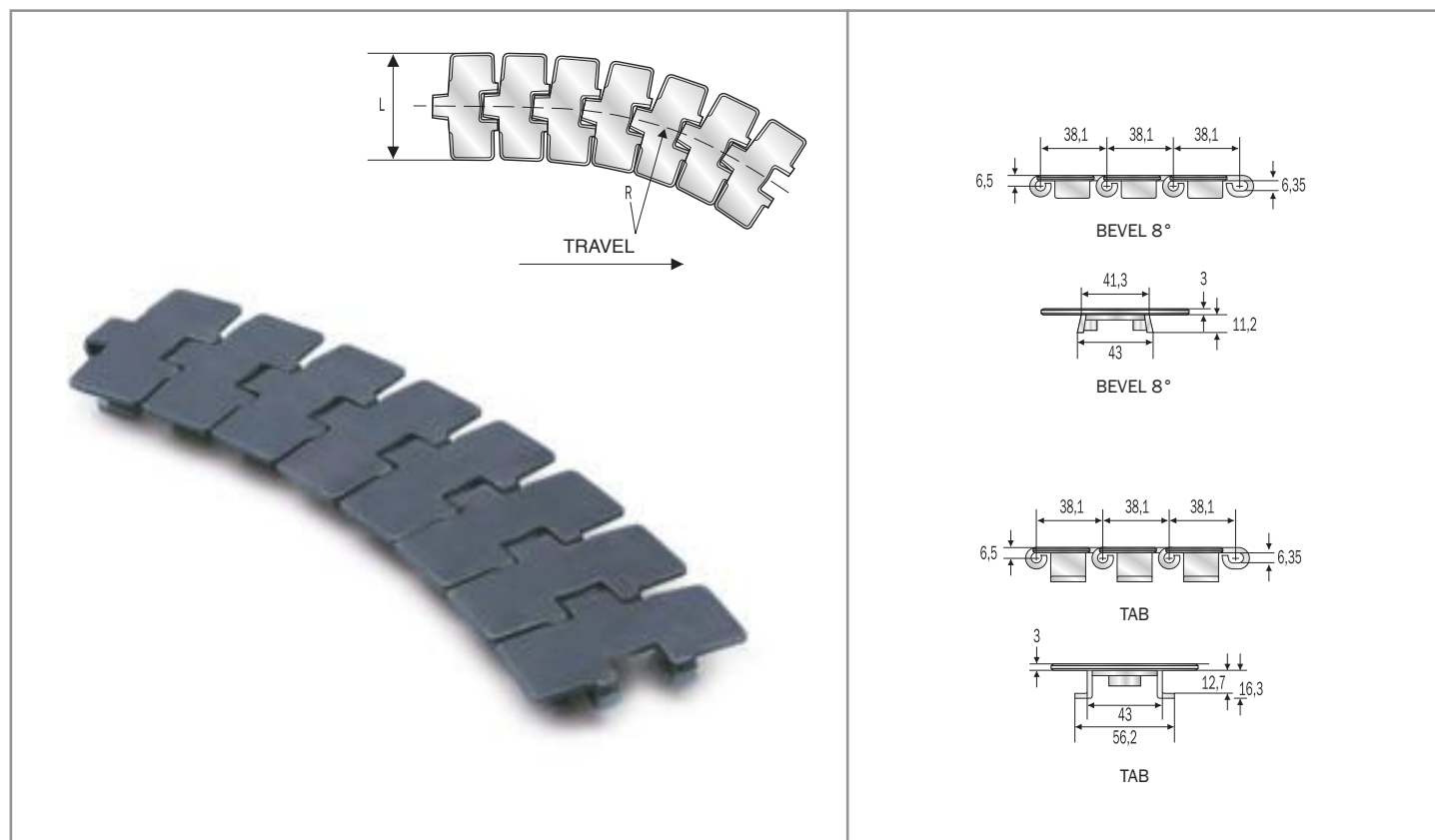

FLEX RXMA - CARBON STEEL

- Heat-treated carbon steel slats, with a surface and core hardness of 43 HRC.
- Case-hardened carbon steel pins.

NOTE: Upon request, the "Flex RXMA Tab" chain with a slat width of 82.5 mm (3 1/4") can be produced in case-hardened carbon steel having a surface hardness of 55 HRC and a core hardness of 40 HRC (code: C.8.93.041).

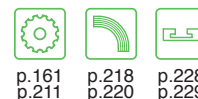

p.161 p.218 p.228
p.211 p.220 p.229

PRODUCT CODE		INTERNAL CODE		CHARACTERISTICS					
		Slat width (mm/ ")		Min. sideflexing radius (mm)	Hardness (HRC)	Flatness (max) mm	Polished hinges	Working Load N (max)	Weight kg/m
BEVEL 8°									
S 881 K325	8.93.040	82.5	3 1/4	457	43	0.40	no	12000	2.90
S 881 K450	8.93.080	114.3	4 1/2	500	43	0.60	no	12000	3.60
S 881 K600*	8.93.100	152.4	6	500	43	0.60	no	12000	4.30
S 881 K750	8.93.110	190.5	7 1/2	500	43	0.90	no	12000	5.30
TAB									
S 881 T K250	8.93.021	63.5	2 1/2	457	43	0.40	no	12000	2.65
S 881 T K325	8.93.041	82.5	3 1/4	457	43	0.40	no	12000	3.10
S 881 T K450	8.93.081	114.3	4 1/2	500	43	0.60	no	12000	3.80
S 881 T K600*	8.93.101	152.4	6	500	43	0.60	no	12000	4.45
S 881 T K750	8.93.111	190.5	7 1/2	500	43	0.90	no	12000	5.50

Standard shipping lengths: 80 pitches = 10 feet = 3,048 metres.

* Size produced only upon request - delivery conditions and terms to be agreed.

sideflexing hinged slat chains

SINGLE HINGE - REDUCED PLATE GAP - 8811 SERIES

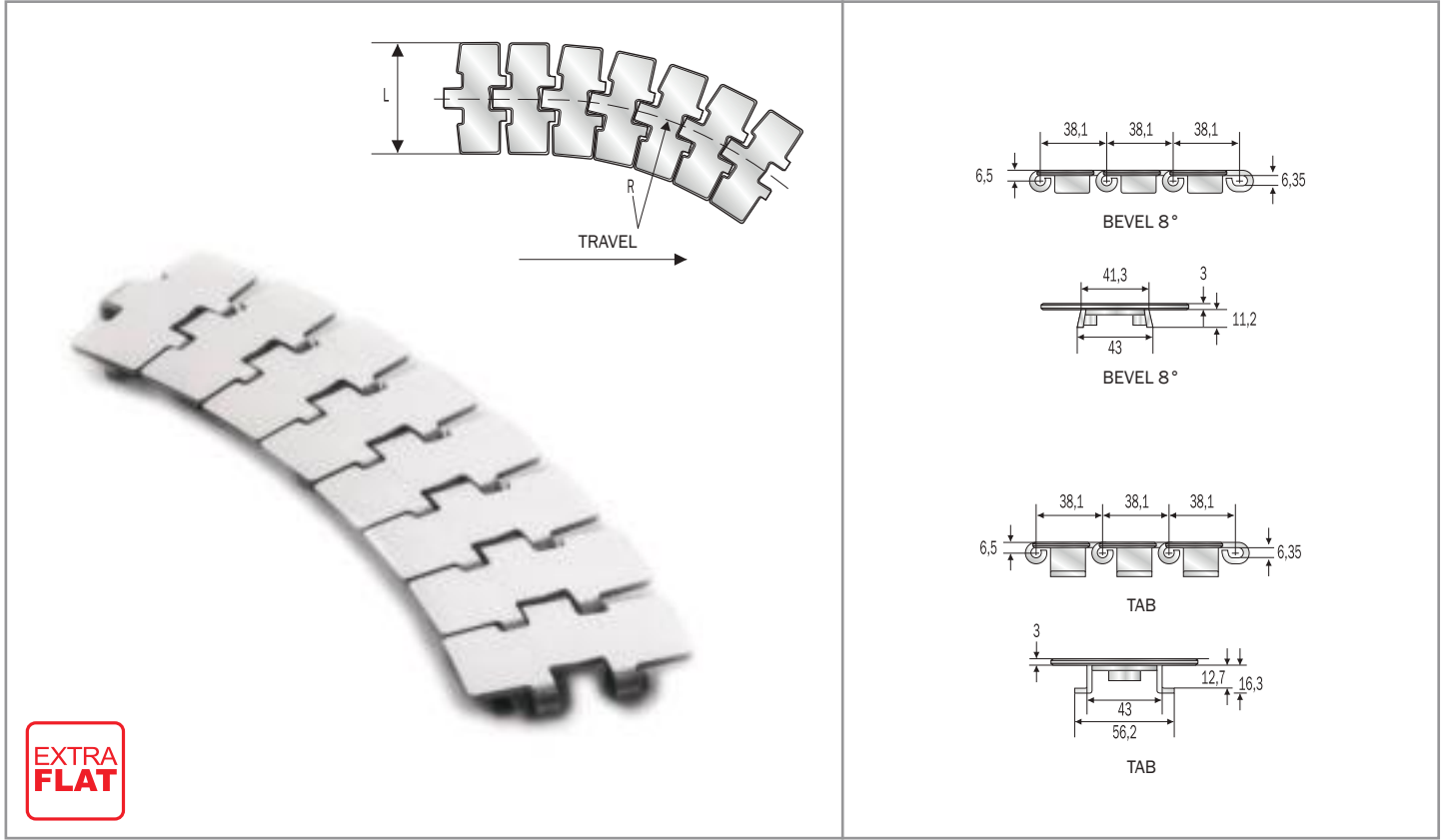

FLEX FMC - INOX

HB PINS
UPON REQUEST

- Ferritic, AISI 430 stainless steel slats, work hardened, with shiny surface having low roughness.
- Chrome-nickel, austenitic stainless steel guide shoes (18% Chrome - 8% Nickel), work hardened for high resistance.
- AISI 431 stainless steel pins, magnetic and work hardened for high resistance.



p.161
p.211

p.218
p.220

p.228
p.229

PRODUCT CODE		INTERNAL CODE		CHARACTERISTICS					
		Slat width (mm/ ")		Min. sideflexing radius (mm)	Hardness (HRC)	Flatness (max) mm	Polished hinges	Working Load N (max)	Weight kg/m
BEVEL 8°									
SS 8811 K325	8.26.040	82.5	3 1/4	500	20	0.18	no	5400	3.10
SS 8811 K330	8.26.044	83.8	3 19/64	500	20	0.25	no	5400	3.15
SS 8811 K450	8.26.080	114.3	4 1/2	610	20	0.40	no	5400	3.80
SS 8811 K750	8.26.110	190.5	7 1/2	610	20	0.40	no	5400	5.50
TAB									
SS 8811 T K325	8.26.041	82.5	3 1/4	500	20	0.18	no	5400	3.10
SS 8811 T K330	8.26.042	83.8	3 19/64	500	20	0.25	no	5400	3.15
SS 8811 T K450	8.26.081	114.3	4 1/2	610	20	0.40	no	5400	3.80
SS 8811 T K750	8.26.111	190.5	7 1/2	610	20	0.40	no	5400	5.50

Standard shipping lengths: 80 pitches = 10 feet = 3,048 metres.

FLEX FMS - HARD INOX

HB OR XHB PINS
UPON REQUEST



- Special, chrome-nickel, stainless steel slats, work hardened for HR, with shiny surface having a roughness of **Ra ≤ 0.3 micron**.
- Chrome-nickel, austenitic stainless steel guide shoes (18% Chrome - 8% Nickel), work hardened for high resistance.
- AISI 431 stainless steel pins, magnetic and work hardened for high resistance.

p.161
p.211

p.218
p.220

p.228
p.229

PRODUCT CODE	INTERNAL CODE	CHARACTERISTICS							
		Slat width (mm/ °)		Min. sideflexing radius (mm)	Hardness (HRC)	Flatness (max) mm	Polished hinges	Working Load N (max)	Weight kg/m
BEVEL 8°									
SSH 8811 K325	S.8.26.040	82.5	3 ^{1/4}	500	30	0.18	no	6000	2.90
SSH 8811 K330	S.8.26.044	83.8	3 ^{19/64}	500	30	0.25	no	6000	2.80
SSH 8811 K350	S.8.26.060	88.9	3 ^{1/2}	500	30	0.25	no	6000	3.10
SSH 8811 K450	S.8.26.080	114.3	4 ^{1/2}	610	30	0.40	no	6000	3.60
SSH 8811 K750	S.8.26.110	190.5	7 ^{1/2}	610	30	0.40	no	6000	5.30
TAB									
SSH 8811 T K325	S.8.26.041	82.5	3 ^{1/4}	500	30	0.18	no	6000	3.10
SSH 8811 T K330	S.8.26.042	83.8	3 ^{19/64}	500	30	0.25	no	6000	3.15
SSH 8811 T K350	S.8.26.061	88.9	3 ^{1/2}	500	30	0.25	no	6000	3.30
SSH 8811 T K450	S.8.26.081	114.3	4 ^{1/2}	610	30	0.40	no	6000	3.80
SSH 8811 T K750	S.8.26.111	190.5	7 ^{1/2}	610	30	0.40	no	6000	5.50

Standard shipping lengths: 80 pitches = 10 feet = 3,048 metres.

FLEX FMD - HQ INOX

XHB PINS
UPON REQUEST



- Special, new stainless steel, chrome-nickel (W.1.4589) slats, work hardened for HR, with low surface roughness, **Ra ≤ 0.2 micron**.
- Chrome-nickel, austenitic stainless steel guide shoes (18% Chrome - 8% Nickel), work hardened for high resistance.
- Special martensitic stainless steel **pins HB series**, magnetic and heat-treated for high resistance.

p.161
p.211

p.218
p.220

p.228
p.229

PRODUCT CODE	INTERNAL CODE	CHARACTERISTICS							
		Slat width (mm/ °)		Min. sideflexing radius (mm)	Hardness (HRC)	Flatness (max) mm	Polished hinges	Working Load N (max)	Weight kg/m
SSX 8811 T K325	D.8.26.041	82.5	3 ^{1/4}	500	30	0.18	no	6000	3.10
SSX 8811 T K330	D.8.26.042	83.8	3 ^{19/64}	500	30	0.18	no	6000	3.15
SSX 8811 T K350	D.8.26.061	88.9	3 ^{1/2}	500	30	0.18	no	6000	3.30

Standard shipping lengths: 80 pitches = 10 feet = 3,048 metres.

FLEX FM - INOX 18/8



- Chrome-nickel, austenitic AISI 304 stainless steel slats (18% Chrome - 8% Nickel), work hardened for HR - shiny - with a roughness of **Ra < 0.5 micron**.
- Chrome-nickel, austenitic stainless steel guide shoes (18% Chrome - 8% Nickel), work hardened for high resistance.
- Austenitic stainless steel pins (18% Chrome - 8% Nickel), work hardened for high resistance.

p.161
p.211

p.218
p.220

p.228
p.229

PRODUCT CODE	INTERNAL CODE	CHARACTERISTICS							
		Slat width (mm/ °)		Min. sideflexing radius (mm)	Hardness (HRC)	Flatness (max) mm	Polished hinges	Working Load N (max)	Weight kg/m
BEVEL 8°									
SSA 8811 K325	8.16.040	82.5	3 ^{1/4}	500	25	0.18	no	5500	2.90
SSA 8811 K350	8.16.060	88.9	3 ^{1/2}	500	25	0.25	no	5500	3.10
TAB									
SSA 8811 T K325	8.16.041	82.5	3 ^{1/4}	500	25	0.18	no	5500	3.10
SSA 8811 T K350	8.16.061	88.9	3 ^{1/2}	500	25	0.25	no	5500	3.30

Standard shipping lengths: 80 pitches = 10 feet = 3,048 metres.

sideflexing hinged slat chains

REDUCED SIDEFLEXING RADIUS - R190

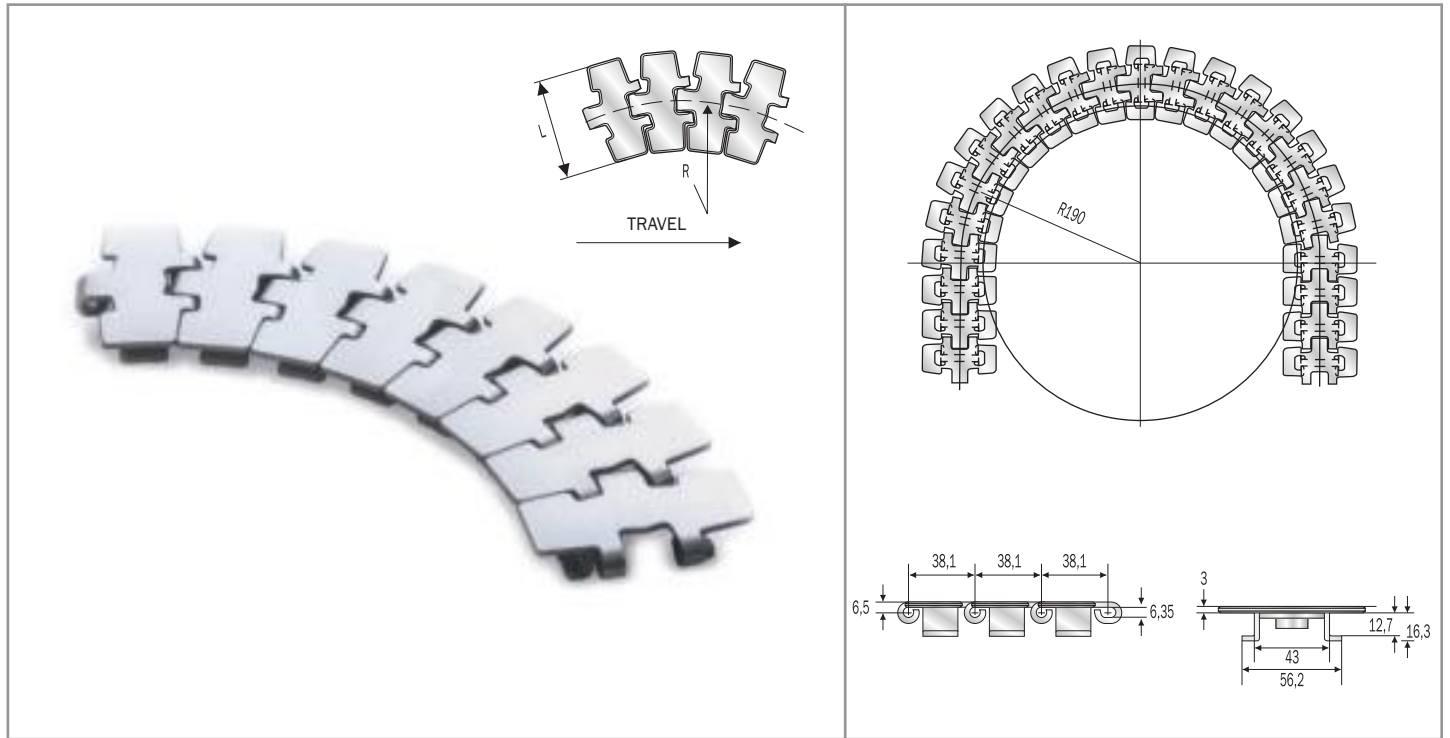

FLEX FMS2 - R = 190mm HARD INOX

HB PINS
UPON REQUEST



- Special, chrome-nickel, stainless steel slats, work hardened for high resistance, with shiny surface having a roughness of $Ra \leq 0.3$ micron.
- Chrome-nickel, austenitic stainless steel guide shoes (18% Chrome - 8% Nickel), work hardened for high resistance.
- AISI 431 stainless steel pins, magnetic and work hardened for high resistance.

p.161
p.211

p.218

p.228

PRODUCT CODE		INTERNAL CODE		CHARACTERISTICS					
		Slat width (mm/ ")		Min. sideflexing radius (mm)	Hardness (HRC)	Flatness (max) mm	Polished hinges	Working Load N (max)	Weight kg/m
SSH 8811 R T K325	S.8.29.041	82.5	3 ^{1/4}	190	30	0.18	no	4900	3.00

FLEX FM2 - R = 190mm INOX 18/8



- Chrome-nickel, austenitic AISI 304 stainless steel slats (18% Chrome - 8% Nickel), work hardened for high resistance - shiny - with a roughness of $Ra < 0.5$ micron.
- Chrome-nickel, austenitic stainless steel guide shoes (18% Chrome - 8% Nickel), work hardened for high resistance.
- Austenitic stainless steel pins (18% Chrome - 8% Nickel), work hardened for high resistance.

p.161
p.211

p.218

p.228

PRODUCT CODE		INTERNAL CODE		CHARACTERISTICS					
		Slat width (mm/ ")		Min. sideflexing radius (mm)	Hardness (HRC)	Flatness (max) mm	Polished hinges	Working Load N (max)	Weight kg/m
SSA 8811 R T K325	8.19.041	82.5	3 ^{1/4}	190	25	0.18	no	4400	3.00

FLEX FMA2 - R = 190mm CARBON STEEL



- Heat-treated carbon steel slats, with a surface and core hardness of 43 HRC.
- Case-hardened carbon steel pins.

NOTE: Upon request, the "Flex FMA2" chain can be produced in case-hardened carbon steel having a surface hardness of 55 HRC and a core hardness of 40 HRC (code: C.8.99.041 FMA2-C)

p.161
p.211

p.218

p.228

PRODUCT CODE		INTERNAL CODE		CHARACTERISTICS					
		Slat width (mm/ ")		Min. sideflexing radius (mm)	Hardness (HRC)	Flatness (max) mm	Polished hinges	Working Load N (max)	Weight kg/m
S 8811 R T K325	8.99.041	82.5	3 ^{1/4}	190	43	0.18	no	9700	3.00

Standard shipping lengths: 80 pitches = 10 feet = 3,048 metres.
Not to be used with a lateral curving disc.

sideflexing hinged slat chains

REDUCED PLATE GAP FOR MAGNETIC SYSTEMS

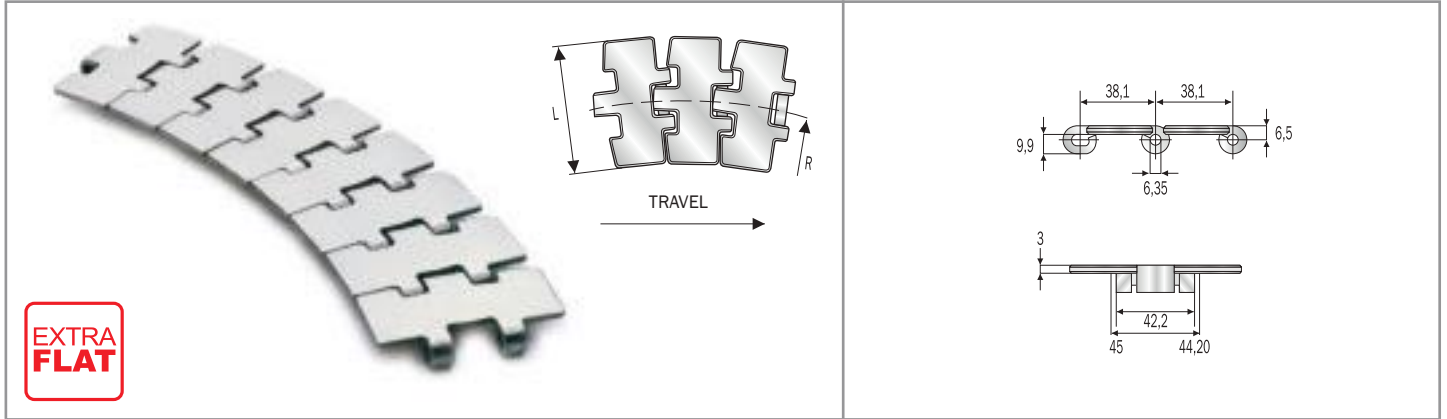

NEW FLEX MAG - INOX

- Ferritic, AISI 430 stainless steel slats, work hardened, with shiny surface having low roughness.
- Special, stainless steel pins, 400 series-magnetic-work hardened for high resistance.



PRODUCT CODE	INTERNAL CODE	CHARACTERISTICS							
		Slat width (mm/ ")	Min. sideflexing radius (mm)	Hardness (HRC)	Flatness (max) mm	Polished hinges	Working Load N (max)	Weight kg/m	
SS 8811 M K325	7.08.040	82.5 3 ^{1/4}	500	20	0.18	yes	5400	2.50	
SS 8811 M K330	7.08.042	83.8 3 ^{19/64}	500	20	0.25	yes	5400	2.65	
SS 8811 M K350*	7.08.060	88.9 3 ^{1/2}	500	20	0.25	yes	5400	2.80	
SS 8811 M K450	7.08.080	114.3 4 ^{1/2}	500	20	0.40	yes	5400	3.20	
SS 8811 M K750	7.08.110	190.5 7 ^{1/2}	500	20	0.40	yes	5400	4.90	

NEW FLEX MAG - HARD INOX

HB PINS
UPON REQUEST



- Special, chrome-nickel, stainless steel slats, work hardened for high resistance, with shiny surface having a roughness of **Ra ≤ 0.3 micron**.
- Special, stainless steel pins, 400 series - magnetic - work hardened for high resistance.



PRODUCT CODE	INTERNAL CODE	CHARACTERISTICS							
		Slat width (mm/ ")	Min. sideflexing radius (mm)	Hardness (HRC)	Flatness (max) mm	Polished hinges	Working Load N (max)	Weight kg/m	
SSH 8811 M K325	S.7.08.040	82.5 3 ^{1/4}	500	30	0.18	yes	6000	2.50	
SSH 8811 M K330	S.7.08.042	83.8 3 ^{19/64}	500	30	0.25	yes	6000	2.65	
SSH 8811 M K350	S.7.08.060	88.9 3 ^{1/2}	500	30	0.25	yes	6000	2.80	
SSH 8811 M K450	S.7.08.080	114.3 4 ^{1/2}	500	30	0.40	yes	6000	3.20	
SSH 8811 M K750	S.7.08.110	190.5 7 ^{1/2}	500	30	0.40	yes	6000	4.90	

NEW FLEX MAG D - HQ INOX

XHB PINS
UPON REQUEST



- Special, new stainless steel, chrome-nickel (W.1.4589) slats - magnetic - work hardened for HR, with shiny surface having a roughness of **Ra ≤ 0.2 micron**.
- Special, martensitic stainless steel pins **HB series**, magnetic and heat-treated for high resistance.

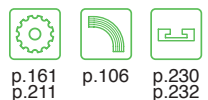

PRODUCT CODE	INTERNAL CODE	CHARACTERISTICS							
		Slat width (mm/ ")	Min. sideflexing radius (mm)	Hardness (HRC)	Flatness (max) mm	Polished hinges	Working Load N (max)	Weight kg/m	
SSX 8811 M K325	D.7.08.040	82.5 3 ^{1/4}	500	30	0.08	yes	6000	2.50	
SSX 8811 M K330	D.7.08.042	83.8 3 ^{19/64}	500	30	0.08	yes	6000	2.65	
SSX 8811 M K350	D.7.08.060	88.9 3 ^{1/2}	500	30	0.40	yes	6000	2.80	
SSX 8811 M K750	D.7.08.110	190.5 7 ^{1/2}	500	30	0.40	yes	6000	4.90	

Standard shipping lengths: 80 pitches = 10 feet = 3,048 metres. * Size produced only upon request - delivery conditions and terms to be agreed.

sideflexing chains

FOR MAGNETIC SYSTEMS - REINFORCED HINGE

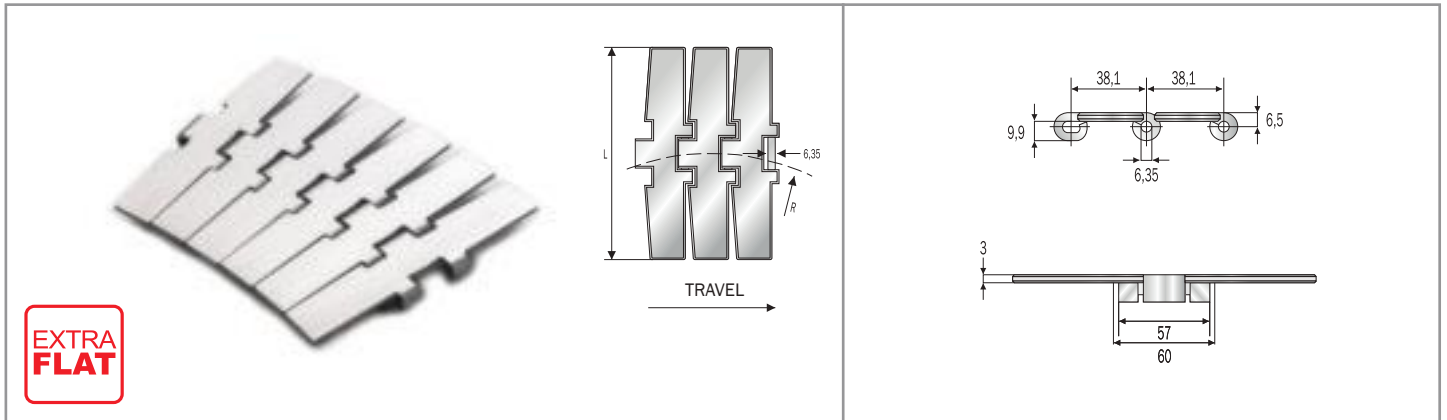

NEW FLEX MAG - HARD INOX

HB PINS
UPON REQUEST



p.157

p.107

p.230

- Special, chrome-nickel, stainless steel slats, work hardened for high resistance, with shiny surface having a roughness of $Ra \leq 0.3$ micron.
- Special, stainless steel pins, 400 series - magnetic - work hardened for high resistance.

PRODUCT CODE	INTERNAL CODE	CHARACTERISTICS						
		Slat width (mm/ ")	Min. sideflexing radius (mm)	Hardness (HRC)	Flatness (max) mm	Polished hinges	Working Load N (max)	Weight kg/m
SSH 8817 M K750	S.7.08.175	190.5 7 ^{1/2}	750	30	0.60	yes	7000	5.03

NEW FLEX MAG D - HQ INOX

XHB PINS
UPON REQUEST



p.157

p.107

p.230

- Special, new stainless steel, chrome-nickel (W.1.4589) slats - magnetic - work hardened for HR, with shiny surface having a roughness of $Ra \leq 0.2$ micron.
- Special, martensitic stainless steel pins HB series, magnetic and heat-treated for high resistance.

PRODUCT CODE	INTERNAL CODE	CHARACTERISTICS						
		Slat width (mm/ ")	Min. sideflexing radius (mm)	Hardness (HRC)	Flatness (max) mm	Polished hinges	Working Load N (max)	Weight kg/m
SSX 8817 M K750	D.7.08.175	190.5 7 ^{1/2}	750	30	0.60	yes	7000	5.03

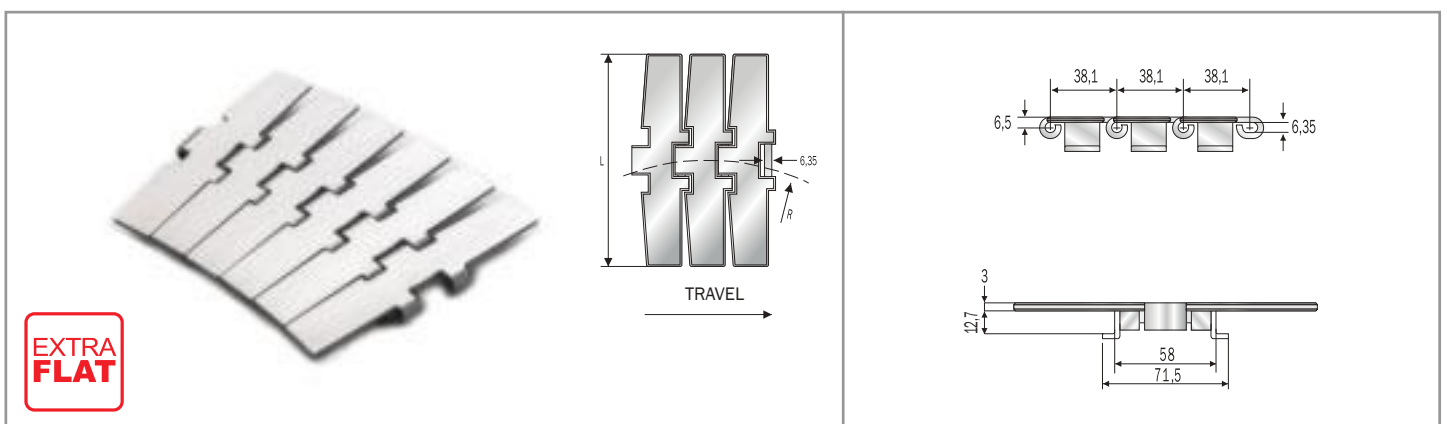

NEW FLEX MAG TAB - HARD INOX

HB PINS
UPON REQUEST



p.157

upon request

p.232

- Special, chrome-nickel, stainless steel slats, work hardened for high resistance, with shiny surface having a roughness of $Ra \leq 0.3$ micron.
- Chrome-nickel, austenitic stainless steel guide shoes (18% Chrome - 8% Nickel), work hardened for high resistance.
- Special, stainless steel pins, 400 series - magnetic - work hardened for high resistance.

PRODUCT CODE	INTERNAL CODE	CHARACTERISTICS						
		Slat width (mm/ ")	Min. sideflexing radius (mm)	Hardness (HRC)	Flatness (max) mm	Polished hinges	Working Load N (max)	Weight kg/m
SSH 8817 T K750	S.7.08.175TAB	190.5 7 ^{1/2}	750	30	0.60	no	7000	5.58

Standard shipping lengths: 80 pitches = 10 feet = 3,048 metres.

straight running chains

WITH RUBBER INSERTS FOR INCLINED CONVEYORS

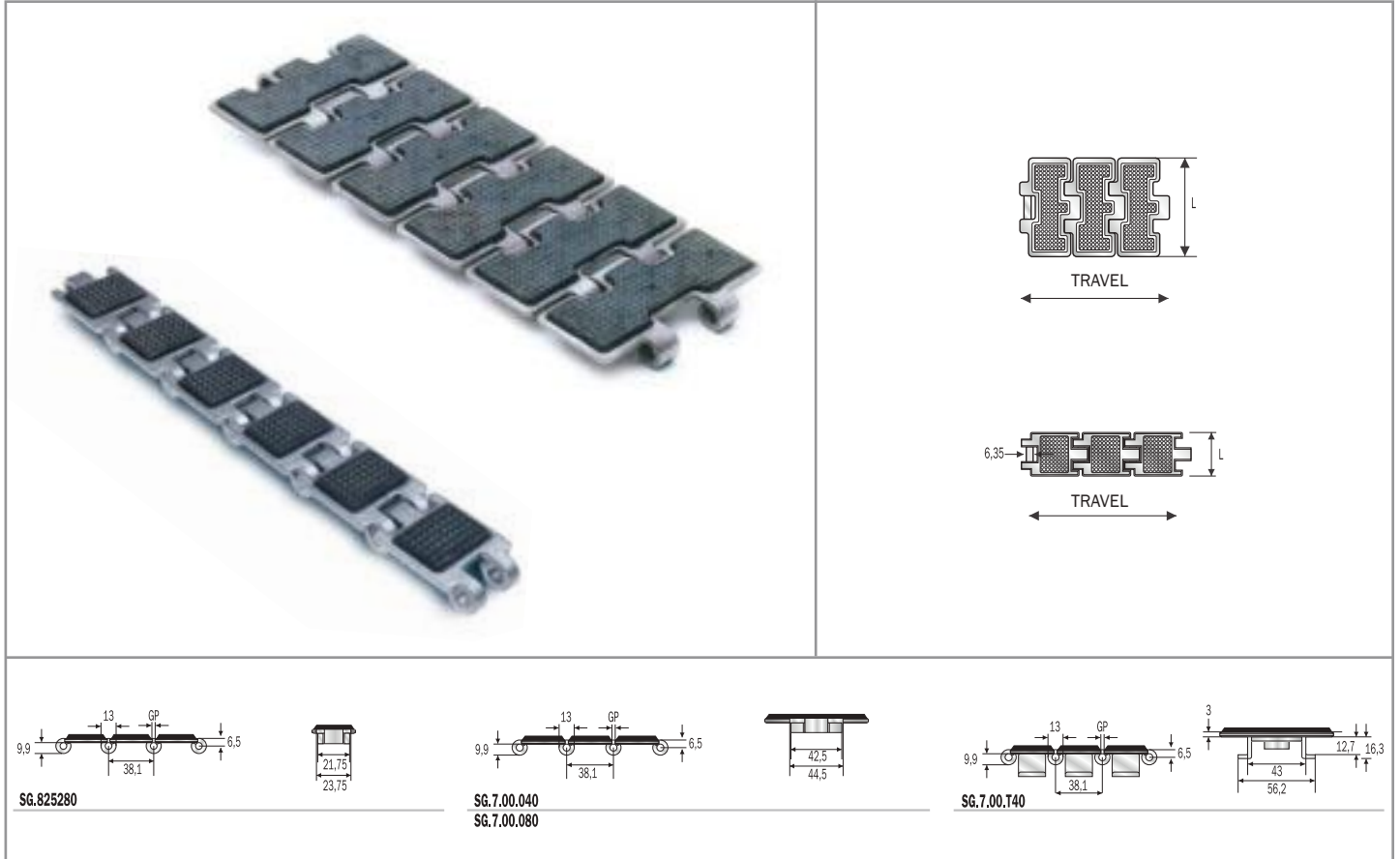

SUPER G / DHG - HARD INOX

XHB PINS
UPON REQUEST

- Special, chrome-nickel, stainless steel slats, work hardened for high resistance, with a rubber insert.
- Chrome-nickel, austenitic stainless steel guide shoes (18% Chrome - 8% Nickel), (Super-G TAB).
- Special, martensitic stainless steel pins **HB series** magnetic and heat-treated for high resistance.



p.142 p.230
p.210 p.232
p.215

PRODUCT CODE	INTERNAL CODE	CHARACTERISTICS						
		Slat width (mm/ ")		Hardness (HRC)	GP (mm)	Working Load N (max)	RCC (mm)	Weight kg/m
SSHR 812 G K125	SG.8.25.280	31.8	1 1/4	30	2.8	2500	75	1.20
SSHR 812 G K325	SG.7.00.040	82.5	3 1/4	30	2.8	6000	75	2.80

Standard shipping lengths: 80 pitches = 10 feet = 3,048 metres.



p.142 p.230
p.210 p.232
p.211

PRODUCT CODE	INTERNAL CODE	CHARACTERISTICS						
		Slat width (mm/ ")		Hardness (HRC)	GP (mm)	Working Load N (max)	RCC (mm)	Weight kg/m
SSHR 812 T G K325	SG.7.00.T40 REDUCED PLATE GAP (1.6)	82.5	3 1/4	30	2.8	6000	75	3.40
SSH 812 G K450	SG.7.00.080	114.3	4 1/2	30	1.6	6000	150	3.50

Standard shipping lengths: 80 pitches = 10 feet = 3,048 metres.

straight running chains

WITH RUBBER INSERTS FOR INCLINED CONVEYORS

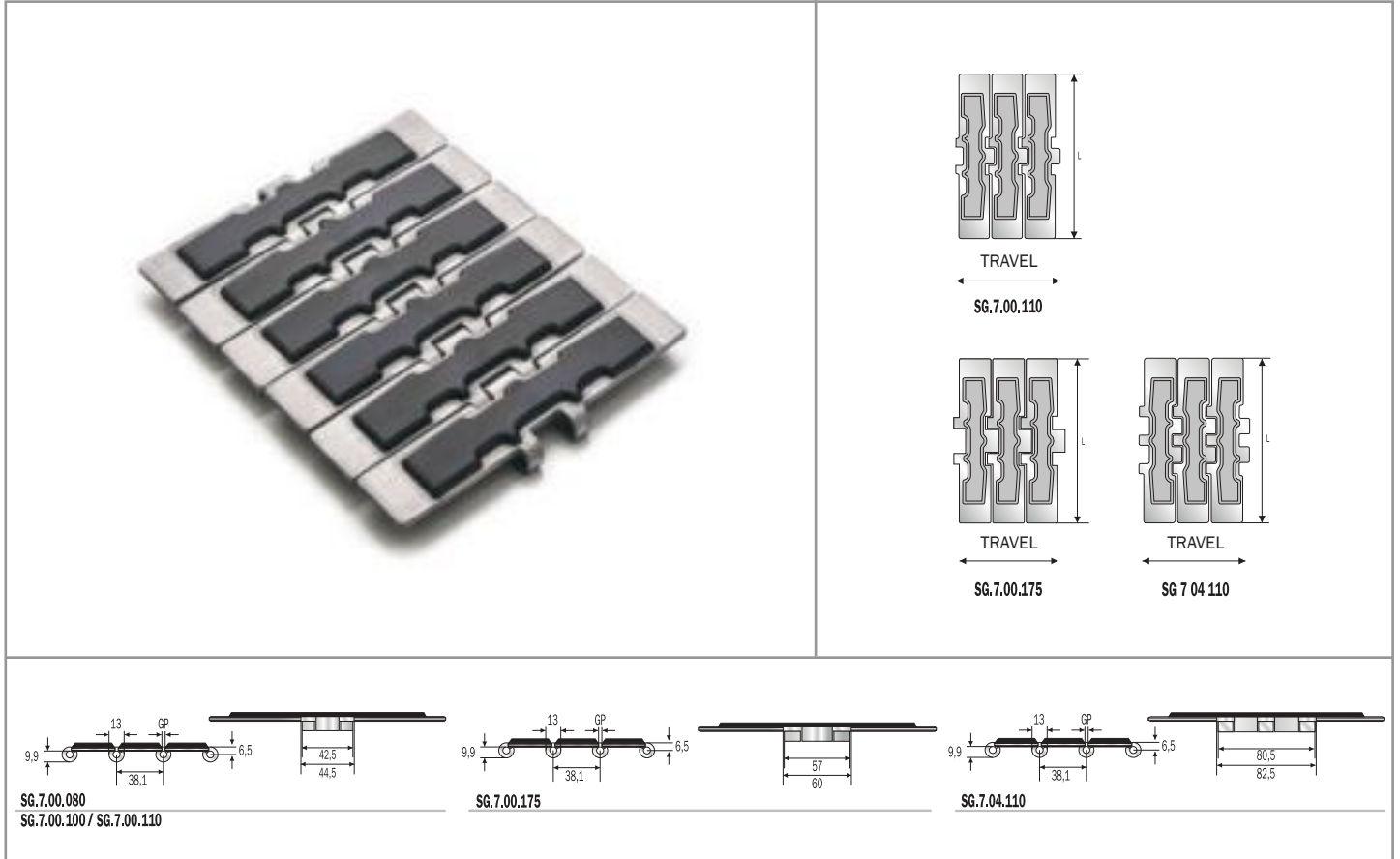

SUPER G / DHG - HARD INOX

XHB PINS
UPON REQUEST

- Special, chrome-nickel, stainless steel slats, work hardened for high resistance, with a rubber insert.
- Chrome-nickel, austenitic stainless steel guide shoes (18% Chrome - 8% Nickel), (Super-G TAB).
- Special, martensitic stainless steel **pins HB series** magnetic and heat-treated for high resistance.



p.142 p.230
p.210 p.232
p.215

PRODUCT CODE	INTERNAL CODE	CHARACTERISTICS						
	REDUCED PLATE GAP (1.6)	Slat width (mm/ ")		Hardness (HRC)	GP (mm)	Working Load N (max)	RCC (mm)	Weight kg/m
SSH 812 G K600	SG.7.00.100	152.4	6	30	1.6	6000	150	4.40
SSH 812 G K750	SG.7.00.110	190.5	7 ^{1/2}	30	1.6	6000	150	5.30

Standard shipping lengths: 80 pitches = 10 feet = 3,048 metres.



p.153 p.230
p.157 p.232
p.211

PRODUCT CODE	INTERNAL CODE	CHARACTERISTICS						
		Slat width (mm/ ")		Hardness (HRC)	GP (mm)	Working Load N (max)	RCC (mm)	Weight kg/m
SSH 8127 G K750	SG.7.00.175	190.5	7 ^{1/2}	30	1.6	7000	150	5.35
SSH 802 G K750	SG.7.04.110	190.5	7 ^{1/2}	30	1.6	15000	150	6.20

Standard shipping lengths: 80 pitches = 10 feet = 3,048 metres.

sideflexing hinged slat chains

WITH RUBBER INSERTS FOR INCLINED CONVEYORS

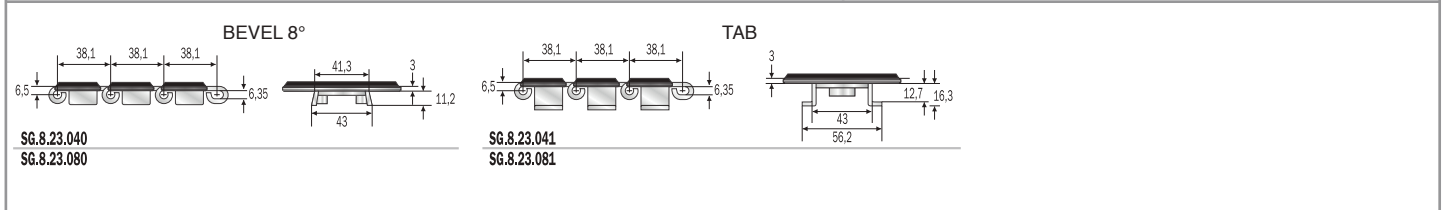
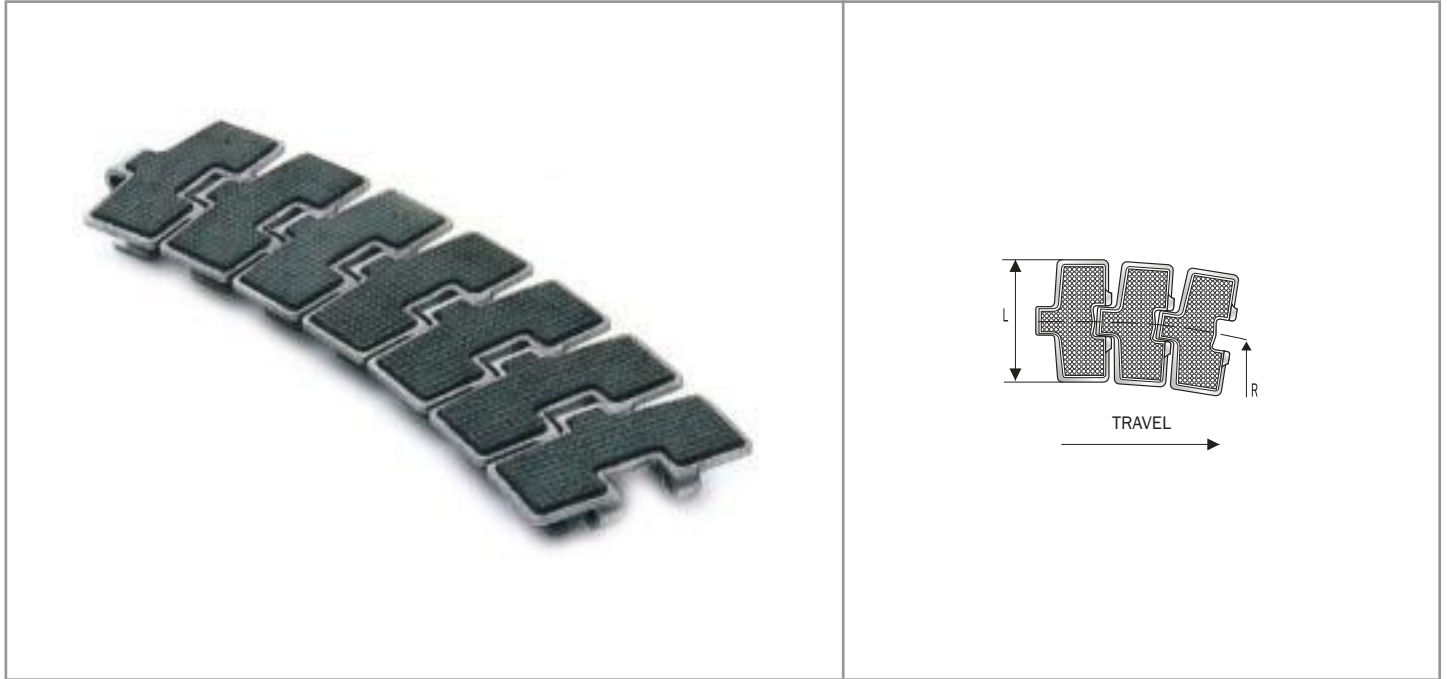

FLEX RXMS G - HARD INOX XHB PINS UPON REQUEST

- Special, chrome-nickel, stainless steel slats, work hardened for high resistance, with a rubber insert.
- Chrome-nickel, austenitic stainless steel guide shoes (18% Chrome - 8% Nickel).
- Special, martensitic stainless steel **pins HB series** magnetic and heat-treated for high resistance.



PRODUCT CODE	INTERNAL CODE	CHARACTERISTICS				
BEVEL 8°		Slat width (mm/ ")	Min. sideflexing radius (mm)	Hardness (HRC)	Working Load N (max)	Weight kg/m
SSH 881 G K325	SG.8.23.040	82.5 3 ¹ / ₄	457	30	6000	3.10
SSH 881 G K450	SG.8.23.080	114.3 4 ¹ / ₂	500	30	6000	3.80
TAB						
SSH 881 T G K325	SG.8.23.041	82.5 3 ¹ / ₄	457	30	6000	3.30
SSH 881 T G K450	SG.8.23.081	114.3 4 ¹ / ₂	500	30	6000	4.00

Standard shipping lengths: 80 pitches = 10 feet = 3,048 metres.

sideflexing hinged slat chains

WITH RUBBER INSERTS FOR INCLINED CONVEYORS

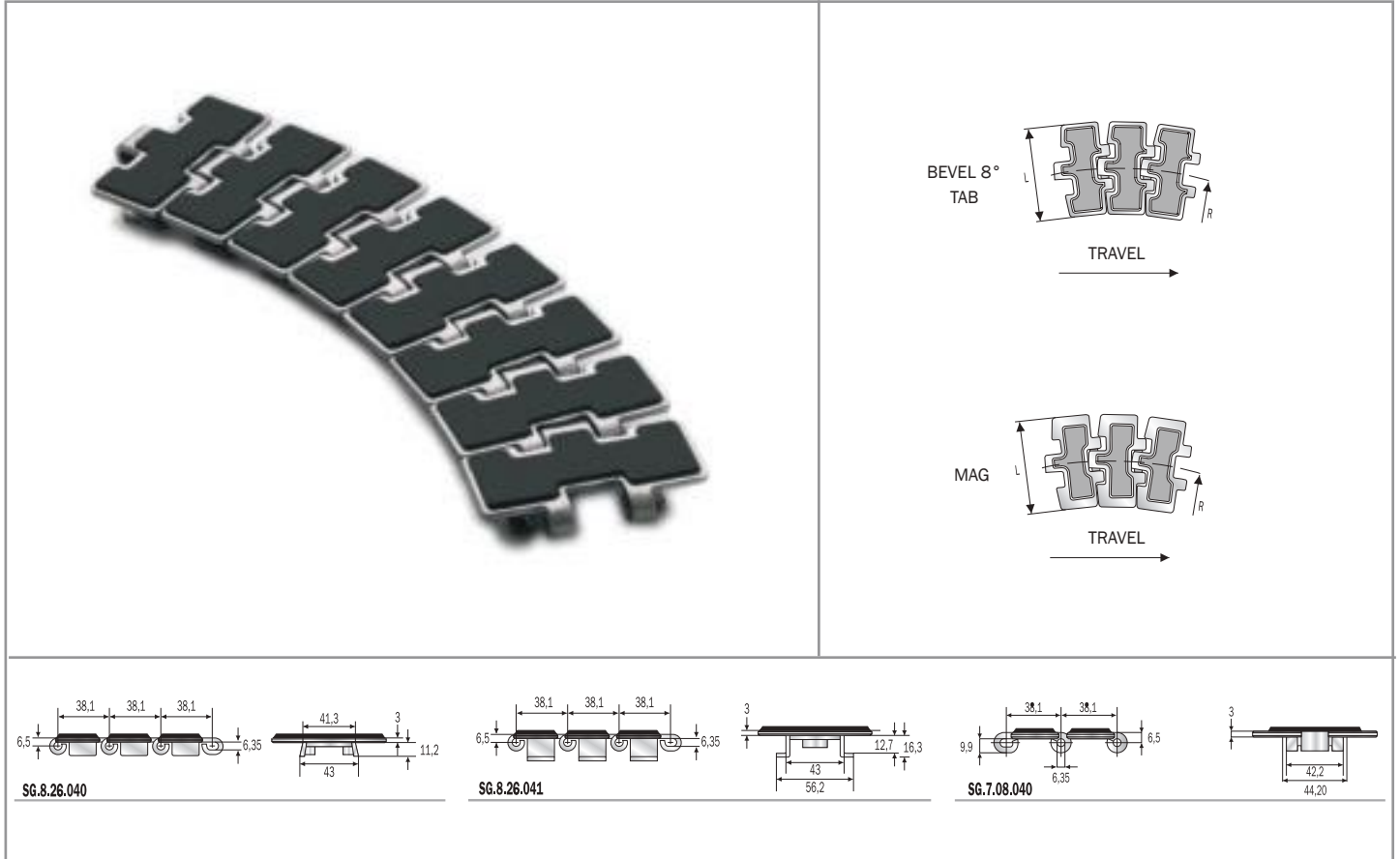

FLEX FMS G / NEW FLEX G MAG - HARD INOX

XHB PINS
UPON REQUEST

- Special, chrome-nickel, stainless steel slats, work hardened for high resistance, with a rubber insert.
- Chrome-nickel, austenitic stainless steel guide shoes (18% Chrome - 8% Nickel), (Flex RXMS - G).
- Special, martensitic stainless steel **pins HB series** magnetic and heat-treated for high resistance.

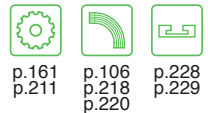

PRODUCT CODE	INTERNAL CODE	CHARACTERISTICS					
		Slat width (mm/ ")		Min. sideflexing radius (mm)	Hardness (HRC)	Working Load N (max)	Weight kg/m
BEVEL 8°							
SSH 8811 G K325*	SG.8.26.040	82.5	3 1/4	500	30	6000	3.10
TAB							
SSH 8811 T G K325*	SG.8.26.041	82.5	3 1/4	500	30	6000	3.30
MAG							
SSH 8811 M G K325	SG.7.08.040	82.5	3 1/4	500	30	6000	2.70

* Size produced only upon request - delivery conditions and terms to be agreed.
Standard shipping lengths: 80 pitches = 10 feet = 3,048 metres.

sideflexing hinged slat chains

WITH RUBBER INSERTS FOR INCLINED CONVEYORS

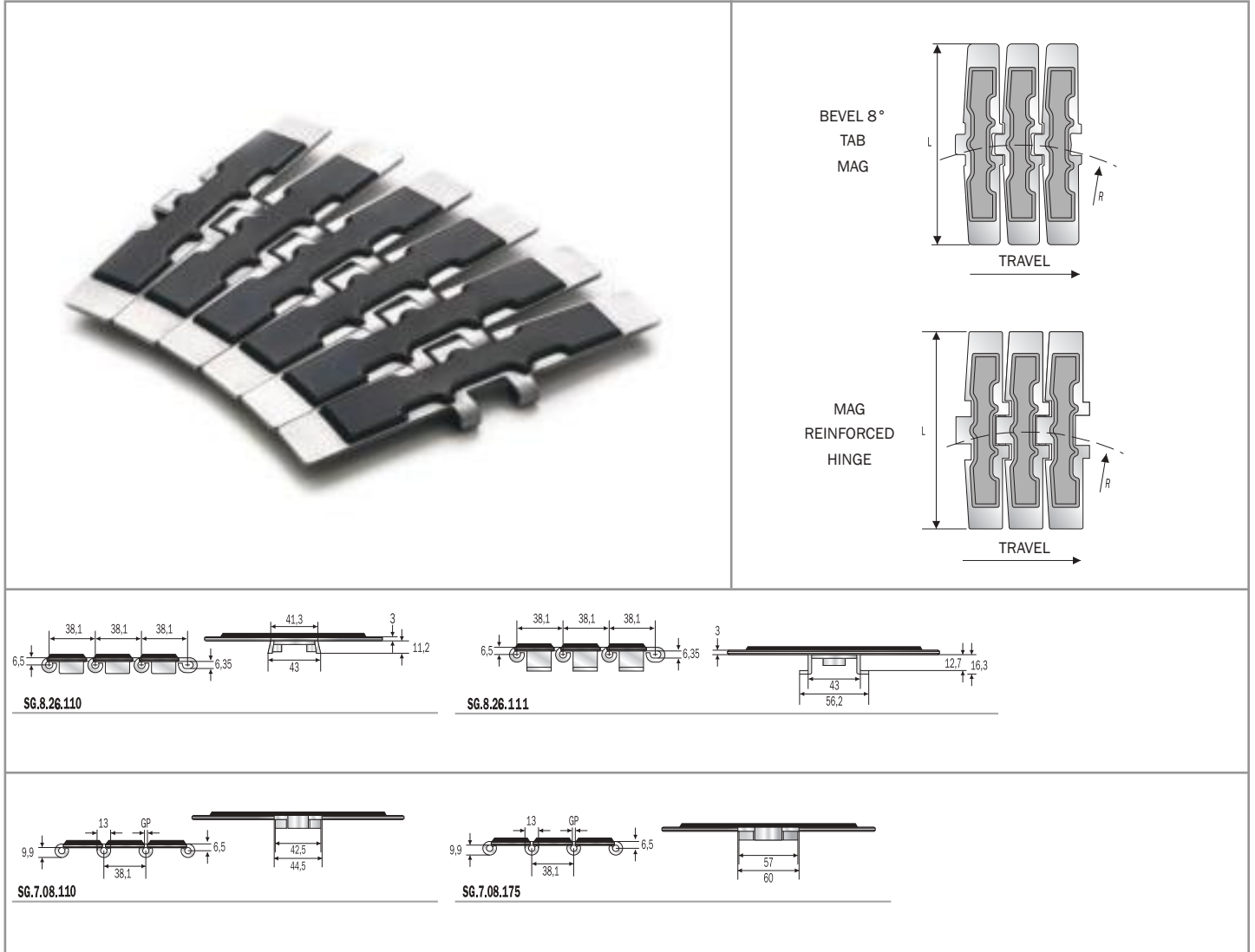

FLEX FMS G / NEW FLEX G MAG - HARD INOX

XHB PINS
UPON REQUEST

- Special, chrome-nickel, stainless steel slats, work hardened for high resistance, with a rubber insert.
- Chrome-nickel, austenitic stainless steel guide shoes (18% Chrome - 8% Nickel).
- Special, martensitic stainless steel **pins HB series** magnetic and heat-treated for high resistance.

p.157	p.106	p.228
p.161	p.218	p.230
p.211	p.220	p.232

PRODUCT CODE	INTERNAL CODE	CHARACTERISTICS					
BEVEL 8°		Slat width (mm/ ")		Min. sideflexing radius (mm)	Hardness (HRC)	Working Load N (max)	Weight kg/m
SSH 8811 G K750 TAB	SG.8.26.110	190.5	7 1/2	500	30	6000	5.50
SSH 8811 T G K750 MAG	SG.8.26.111	190.5	7 1/2	500	30	6000	5.70
SSH 8811 M G K750 MAG REINFORCED HINGE	SG.7.08.110	190.5	7 1/2	500	30	6000	5.10
SSH 8817 M G K750	SG.7.08.175	190.5	7 1/2	750	30	7000	5.14

Standard shipping lengths: 80 pitches = 10 feet = 3,048 metres.

sideflexing hinged slat chains

WITH RUBBER INSERTS FOR INCLINED CONVEYORS

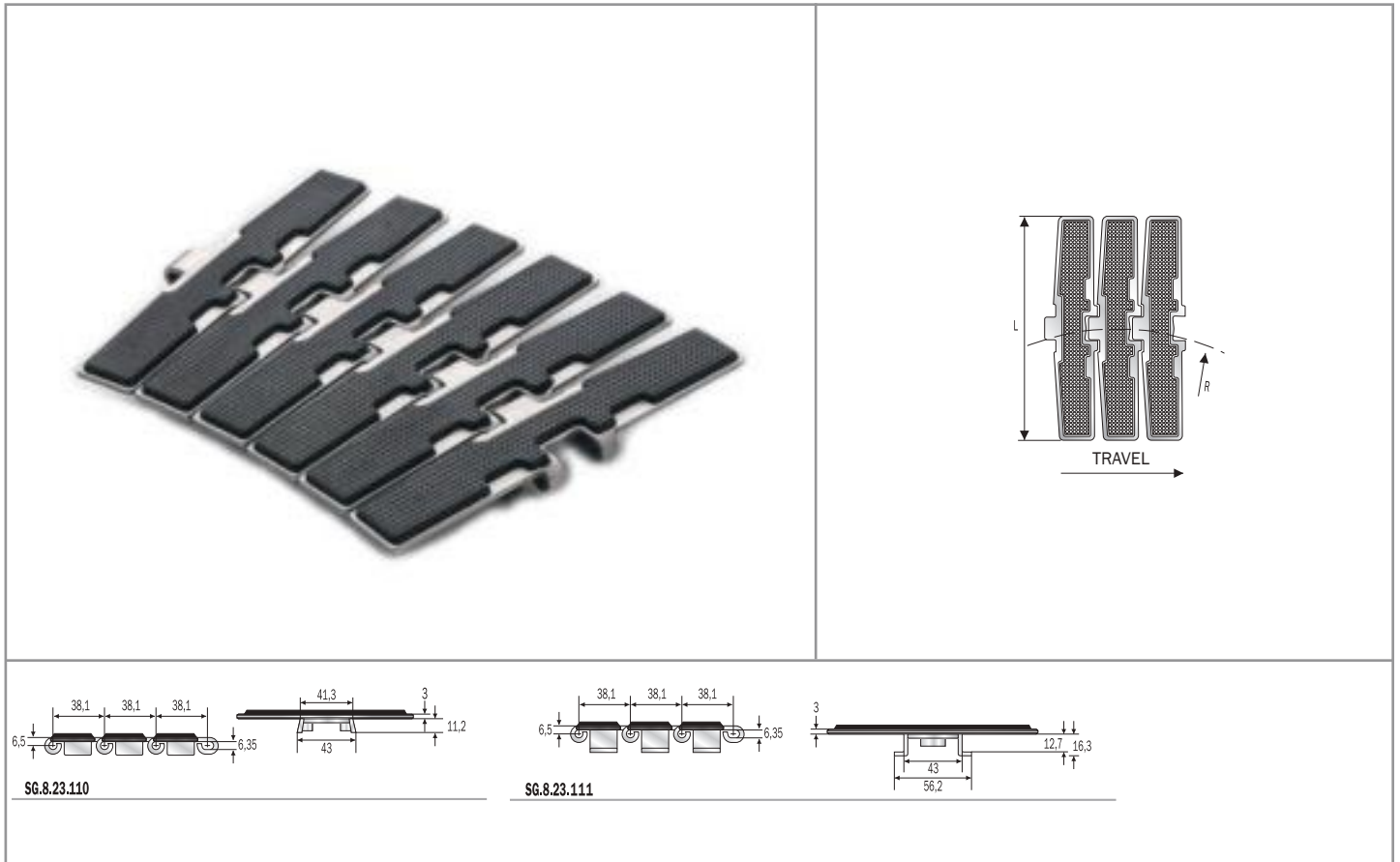

FLEX RXMS G - HARD INOX

XHB PINS
UPON REQUEST

- Special, chrome-nickel, stainless steel slats, work hardened for high resistance, with a rubber insert.
- Chrome-nickel, austenitic stainless steel guide shoes (18% Chrome - 8% Nickel)
- Special, martensitic stainless steel **pins HB series** magnetic and heat-treated for high resistance.



p.161
p.211



p.218
p.220



p.228
p.229

PRODUCT CODE	INTERNAL CODE	CHARACTERISTICS					
BEVEL 8°		Slat width (mm/ ")		Min. sideflexing radius (mm)	Hardness (HRC)	Working Load N (max)	Weight kg/m
SSH 881 G K750*	SG.8.23.110	190.5	7 1/2	500	30	6000	5.50
TAB							
SSH 881 T G K750*	SG.8.23.111	190.5	7 1/2	500	30	6000	5.70

* Size produced only upon request - delivery conditions and terms to be agreed.
Standard shipping lengths: 80 pitches = 10 feet = 3,048 metres.

straight running plate top chains

1864 SERIES

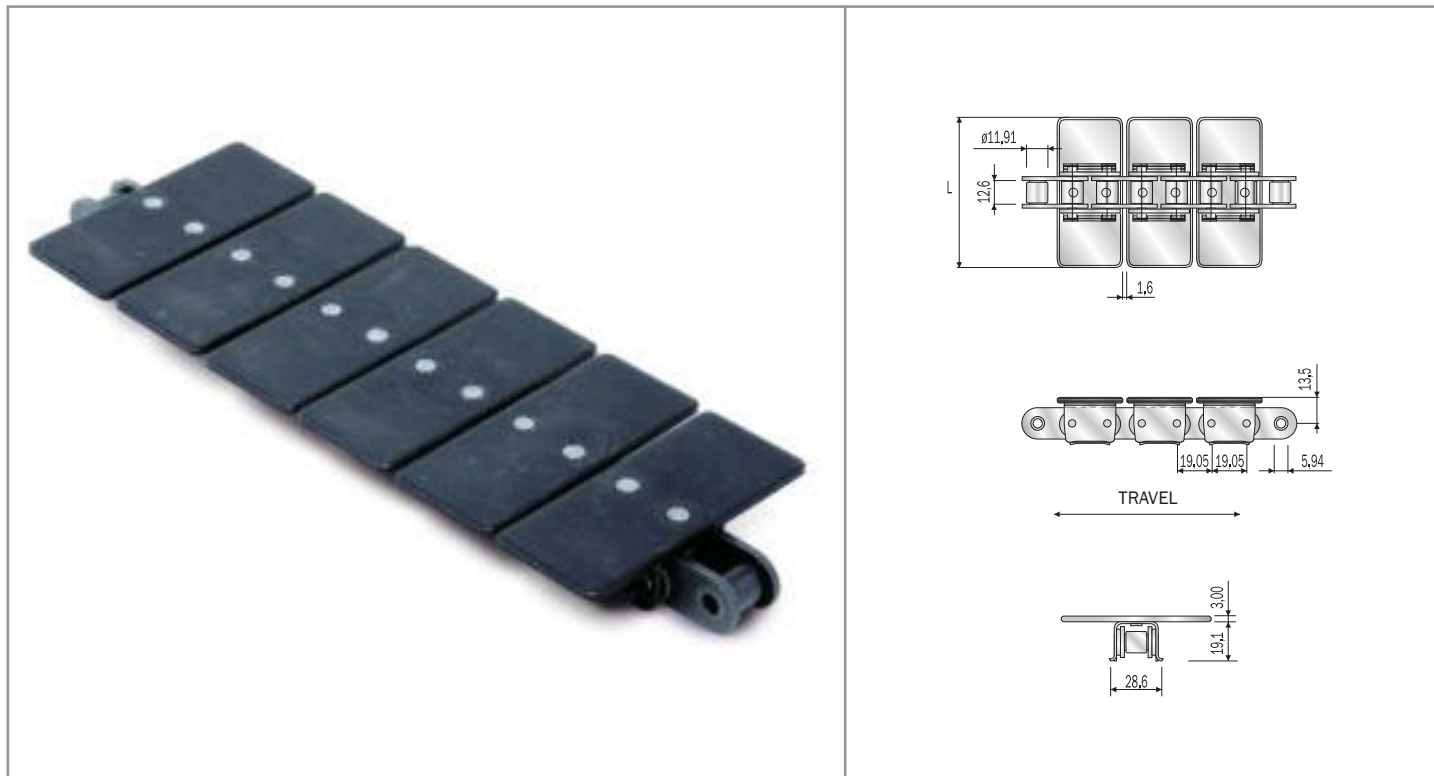

1864

- This high speed, high capacity series offers better efficiency and reliability in applications where high temperatures or abrasive materials are involved.
- Steel and stainless steel top plates.
- Base roller chain, 19,05 mm - 3/4" pitch ANSI 60.

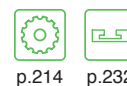

p.214 p.232

PRODUCT CODE		INTERNAL CODE	CHARACTERISTICS		
			Slat width (mm)	Ultimate strenght (N)	Weight kg/m
1864 K325	1864.CC.041		82.5	37000	3.33
1864 K450	1864.CC.081		114.3	37000	4.00
1864 K600	1864.CC.101		152.4	37000	5.33
1864 K750	1864.CC.111		190.5	37000	5.68
1864 A K325	1864.CS.041		82.5	37000	3.33
1864 A K450	1864.CS.081		114.3	37000	4.00
1864 A K600	1864.CS.101		152.4	37000	5.33
1864 A K750	1864.CS.111		190.5	37000	5.68
1864 SS K325	1864.SS.041		82.5	26000	3.33
1864 SS K450	1864.SS.081		114.3	26000	4.00
1864 SS K600	1864.SS.101		152.4	26000	5.33
1864 SS K750	1864.SS.111		190.5	26000	5.68

NOTE ON MATERIALS

1864 - steel base roller chain, steel top plate.

1864 A - steel base roller chain, stainless steel top plate.

1864 SS - stainless steel base roller chain, stainless steel top plate.

sideflexing plate top chains

1874 SERIES

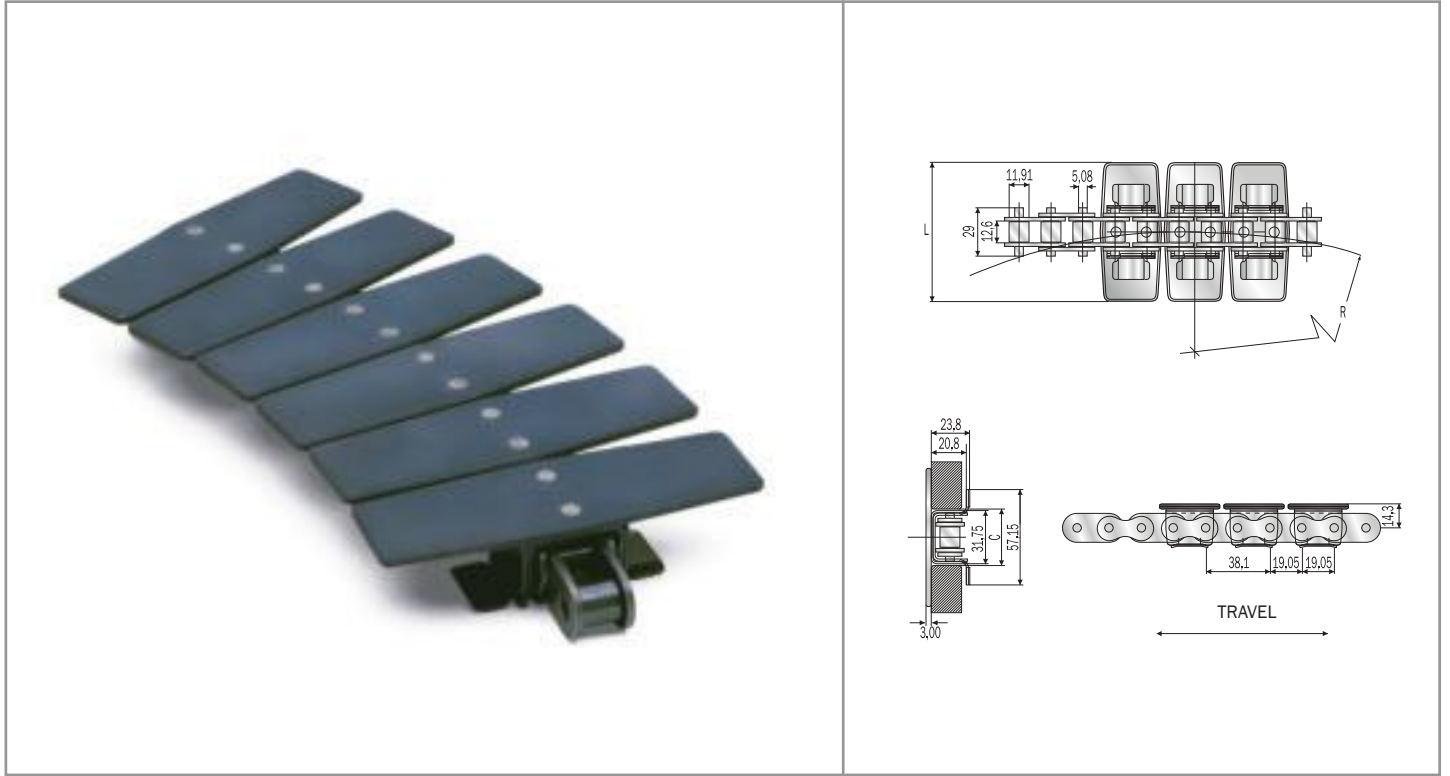

1874

- This high speed, high capacity series offers better efficiency and reliability in applications where high temperatures or abrasive materials are involved.
- Steel and stainless steel top plates.
- Base roller chain, 19,05 mm - 3/4" pitch ANSI 63 SB.

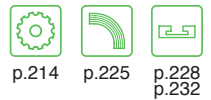

PRODUCT CODE	INTERNAL CODE	CHARACTERISTICS					
		Slat width (mm)	Ultimate strenght (N)	Straight C (mm)	Curve C (mm)	R (mm)	Weight kg/m
1874 K325	1874.CC.041	82.5	27000	34.1	34.6	356	4.20
1874 K450	1874.CC.081	114.3	27000	34.1	34.6	356	4.80
1874 K600	1874.CC.101	152.4	27000	34.1	34.6	457	5.70
1874 K750	1874.CC.111	190.5	27000	34.1	34.6	610	6.40
1874 A K325	1874.CS.041	82.5	27000	34.1	34.6	356	4.20
1874 A K450	1874.CS.081	114.3	27000	34.1	34.6	356	4.80
1874 A K600	1874.CS.101	152.4	27000	34.1	34.6	457	5.70
1874 A K750	1874.CS.111	190.5	27000	34.1	34.6	610	6.40
1874 SS K325	1874.SS.041	82.5	21000	34.1	34.6	356	4.20
1874 SS K450	1874.SS.081	114.3	21000	34.1	34.6	356	4.80
1874 SS K600	1874.SS.101	152.4	21000	34.1	34.6	457	5.70
1874 SS K750	1874.SS.111	190.5	21000	34.1	34.6	610	6.40

NOTE ON MATERIALS

1874 - steel base roller chain, steel top plate.

1874 A - steel base roller chain, stainless steel top plate.

1874 SS - stainless steel base roller chain, stainless steel top plate.

steel corrosion resistance table

LEGEND

- = Little resistance - not recommended
- = Average resistance
- = Good resistance - it can be used

CHEMICAL AGENT	FERRITIC STAINLESS STEEL	SPECIAL Cr-Ni STAINLESS STEEL	SPECIAL NEW Cr-Ni STAINLESS STEEL	AUSTENITIC STAINLESS STEEL	AUSTENITIC STAINLESS STEEL	CARBON STEEL
	INOX	HARD INOX	HQ INOX	INOX 18/8	INOX 316	
A Acetic acid	○	○	○	●	●●	○
Acetone	●●	●●	●●	●●	●●	○
Aluminium chloride	○	○	○	●	●	○
Ammonia	●●	●●	●●	●●	●●	○
Ammonium chloride	○	○	○	●	●	○
Amyl alcohol	○	●	●	●●	●●	○
Aniline	●	●	●	●●	●●	○
Animal oil	●●	●●	○○	●●	●●	●●
B Beer	●●	●●	●●	●●	●●	●
Benzene	○	●	●	●	●●	○
Benzoic acid	○	○	○	○	●	○
Benzol	●	●	●	●	●●	●
Boric acid	○	●	●	●	●	○
Brine	○	○	○	○	●●	○
Butter	●	●	●	●	●●	○
Butyl alcohol	○	●	●	●	●●	○
Butyric acid	○	○	○	○	●	○
C Calcium chloride	○	○	○	○	●	○
Carbon disulphide	●	●	●	●	●●	○
Carbon tetrachloride	●	●	●	●	●●	●
Carbonated drinks	●●	●●	●●	●●	●●	○
Caustic soda (20%)	●●	●●	●●	●●	●●	○
Chlorine water	○	○	○	○	○	○
Chloroform	○	●	●	●	●●	○
Citric acid	●	●	●	●	●●	○
Copper sulphate	●	●	●	●	●●	○
D Diet oil	●●	●●	●●	●●	●●	●
Diet fat	●●	●●	●●	●●	●●	○
Diluted acetic acid	○	○	○	○	●●	○
Distilled water	●●	●●	●●	●●	●●	○
E Ethyl acetate	○	○	○	○	●	○
Ethyl alcohol	○	●	●	●	●●	○
Ethyl chloride	●	●●	●●	●●	●●	○
F Flax oil	●	●	●	●	●●	●
Formaldehyde	○	●	●	●	●●	○
Formic acid	○	○	○	○	○	○
Freon 12	○	○	○	○	●●	○
Fresh water	●●	●●	●●	●●	●●	○
Fruit juice	●	●	●	●	●●	○

The indicated data are approximate as the corrosion resistance of the above-mentioned steels, according to the conditions of use, is related to the work temperature, the concentration of the chemical agent, the duration of the contact with it, etc.

steel corrosion resistance table

LEGEND

- = Little resistance - not recommended
- = Average resistance
- = Good resistance - it can be used

CHEMICAL AGENT	FERRITIC STAINLESS STEEL	SPECIAL Cr-Ni STAINLESS STEEL	SPECIAL NEW Cr-Ni STAINLESS STEEL	AUSTENITIC STAINLESS STEEL	AUSTENITIC STAINLESS STEEL	CARBON STEEL
	INOX	HARD INOX	HQ INOX	INOX 18/8	INOX 316	
G Gasoline	●	●	●	●	●●	●
Glycerine	●	●	●	●	●●	○
H Hydrochloric acid	○	○	○	○	○	○
Hydrofluoric acid	○	○	○	○	○	○
Hydrogen peroxide	○	●	●	●	●●	○
I Iodine	○	○	○	○	○	○
Iron chloride	○	○	○	○	●	○
L Lactid acid	○	○	●	●	●●	○
M Magnesium chloride	○	○	○	○	●	○
Mercury	○	●	●	●	●	○
Methyl alcohol	○	●	●	●	●●	○
Methylene chloride	○	○	●	●	●	○
Milk	●●	●	●●	●●	●●	●
N Nitric acid	●	●	●	●	●●	○
O Oil	●●	●●	●●	●●	●●	●●
Oil ether	○	●	●	●	●●	○
Oleic acid	●	●	●	●	●	○
P Paraffin	●●	●●	●●	●●	●●	●●
Phenol	○	○	○	○	●●	○
Phosphoric acid	●	●	●	●	●●	○
Potassium hydroxine	○	○	○	○	●●	○
S Sea water	○	○	●	●	●●	○
Silver nitrate	○	○	○	○	●	○
Soapy water	●●	●●	●●	●●	●●	○
Sodium carbonate	●	●	●	●	●●	○
Sodium chloride	○	○	○	○	●	○
Sodium hydroxine	○	○	○	○	●	○
Sodium hypochlorite	○	○	○	○	○	○
Sodium silicate	○	○	○	○	●●	○
Sodium sulphate	●	●	●	●	●●	○
Soft drinks	●●	●●	●●	●●	●●	○
Sulphuric acid	○	○	○	○	●	○
T Tartaric acid	○	○	●	●	●	○
Trichlorethylene	●	●	●	●	●●	●
Turpentine	●●	●●	●●	●●	●●	○
V Vegetable juice	●	●	●	●	●●	○
Vegetable oil	●●	●●	●●	●●	●●	●●
Vinegar	○	○	●	●	●●	○
W Whiskey	●	●	●	●	●●	○
Wine	●	●	●	●	●●	○
X Xilol	●●	●●	●●	●●	●●	●
Z Zinc chloride	○	○	○	○	●	○

The indicated data are approximate as the corrosion resistance of the above-mentioned steels, according to the conditions of use, is related to the work temperature, the concentration of the chemical agent, the duration of the contact with it, etc.

Алматы (727)345-47-04
 Ангарск (3955)60-70-56
 Архангельск (8182)63-90-72
 Астрахань (8512)99-46-04
 Барнаул (3852)73-04-60
 Белгород (4722)40-23-64
 Благовещенск (4162)22-76-07
 Брянск (4832)59-03-52
 Владивосток (423)249-28-31
 Владикавказ (8672)28-90-48
 Владимир (4922)49-43-18
 Волгоград (844)278-03-48
 Вологда (8172)26-41-59
 Воронеж (473)204-51-73
 Екатеринбург (343)384-55-89

Иваново (4932)77-34-06
 Ижевск (3412)26-03-58
 Иркутск (395)279-98-46
 Казань (843)206-01-48
 Калининград (4012)72-03-81
 Калуга (4842)92-23-67
 Кемерово (3842)65-04-62
 Киров (8332)68-02-04
 Коломна (4966)23-41-49
 Кострома (4942)77-07-48
 Краснодар (861)203-40-90
 Красноярск (391)204-63-61
 Курск (4712)77-13-04
 Курган (3522)50-90-47
 Липецк (4742)52-20-81

Магнитогорск (3519)55-03-13
 Москва (495)268-04-70
 Мурманск (8152)59-64-93
 Набережные Челны (8552)20-53-41
 Нижний Новгород (831)429-08-12
 Новокузнецк (3843)20-46-81
 Ноябрьск (3496)41-32-12
 Новосибирск (383)227-86-73
 Омск (3812)21-46-40
 Орел (4862)44-53-42
 Оренбург (3532)37-68-04
 Пенза (8412)22-31-16
 Петрозаводск (8142)55-98-37
 Псков (8112)59-10-37
 Пермь (342)205-81-47

Ростов-на-Дону (863)308-18-15
 Рязань (4912)46-61-64
 Самара (846)206-03-16
 Санкт-Петербург (812)309-46-40
 Саратов (845)249-38-78
 Севастополь (8692)22-31-93
 Саранск (8342)22-96-24
 Симферополь (3652)67-13-56
 Смоленск (4812)29-41-54
 Сочи (862)225-72-31
 Ставрополь (8652)20-65-13
 Сургут (3462)77-98-35
 Сыктывкар (8212)25-95-17
 Тамбов (4752)50-40-97
 Тверь (4822)63-31-35

Тольятти (8482)63-91-07
 Томск (3822)98-41-53
 Тула (4872)33-79-87
 Тюмень (3452)66-21-18
 Ульяновск (8422)24-23-59
 Улан-Удэ (3012)59-97-51
 Уфа (347)229-48-12
 Хабаровск (4212)92-98-04
 Чебоксары (8352)28-53-07
 Челябинск (351)202-03-61
 Ставрополь (8202)49-02-64
 Чита (3022)38-34-83
 Якутск (4112)23-90-97
 Ярославль (4852)69-52-93

Россия +7(495)268-04-70

Казахстан +7(727)345-47-04

Беларусь +(375)257-127-884

Узбекистан +998(71)205-18-59

Киргизия +996(312)96-26-47